

Analysis of the operations of an intermodal barge terminal

Peer-reviewed author version

VERDONCK, Lotte; CARIS, An; RAMAEKERS, Katrien & JANSSENS, Gerrit K. (2012) Analysis of the operations of an intermodal barge terminal. In: Bruzzone, Agostino G.; Gronald, Manfred; Merkurjev, Yury; Piera, Miguel Angel; Talley, Wayne (Ed.). Proceedings of HMS: The International Conference on Harbour, Maritime & Multimodal Logistics Modelling and Simulation 2012, p. 11-21.

Handle: <http://hdl.handle.net/1942/14549>

ANALYSIS OF THE OPERATIONS OF AN INTERMODAL BARGE TERMINAL

L. Verdonck^(a), A. Caris^(b), K. Ramaekers^(c) and G.K. Janssens^(d)

^(a) ^(b) ^(c) ^(d) Hasselt University, Transportation Research Institute (IMOB)

Wetenschapspark – Building 5, 3590 Diepenbeek, Belgium

^(b) Research Foundation Flanders (FWO), Egmontstraat 5, 1000 Brussel, Belgium

^(a)lotte.verdonck@uhasselt.be, ^(b)an.caris@uhasselt.be,

^(c)katrien.ramaekers@uhasselt.be, ^(d)gerrit.janssens@uhasselt.be

ABSTRACT

This paper studies the operations of intermodal barge terminals. The objective is to increase the terminal's efficiency by supporting the operational planning of the terminal operator. For this purpose a review on general and process specific barge terminal planning problems, discussed in current scientific literature, is provided. This theoretical knowledge is verified in practice by means of a comparison with operational planning realities at Haven Genk, a Belgian trimodal terminal. Finally, a simulation study based on Haven Genk data is performed to investigate whether vessel size and number of vessels in use have an impact on barge terminal efficiency.

Keywords: barge terminal, operational planning, discrete event simulation

1. INTRODUCTION

During the last decades, the quality of freight transport experiences an increasing pressure. The huge growth in and the dominant role played by road transport have caused a wide variety of problems. These problems induce a decline in the reliability of freight transport and an increase in customers' lead time. In addition, policy makers realise that the negative impacts of this type of transportation on nature and the environment need to be stopped (Konings et al. 2006).

A shift from freight transport by road to intermodal transportation is an opportunity to meet the need for an efficient and environmentally friendly transport mode. Intermodal transportation means that the main transport is performed by alternative transport modes like rail, barge or sea, while the secondary pre- and post-transport goes by road and is as short as possible (Macharis and Verbeke 1999). In intermodal transport a central role is played by terminals which take care of the transshipment of freight from one transportation mode to another. However, operations cost of intermodal terminals constitutes an important cost element in intermodal transportation, which reduces its competitive strength against unimodal road transport. For this reason, it is essential to ensure that intermodal terminals work as efficient and effective as possible.

Minimising container throughput time and reducing transshipment costs may lead to reinforced market power for the intermodal transport sector, improving chances for a modal shift.

To determine how operational costs of transshipment terminals may be reduced, it is necessary to perform a thorough study of its operations. In this way, opportunities for improvement may be traced and operational efficiency of intermodal terminals may be enhanced. This paper focuses on barge terminals, which perform transshipment between road and barge transportation.

The remainder of this paper is organised as follows. Section 2 provides a review of the various planning problems a barge terminal operator can be confronted with on different organisational and temporal levels. Section 3 describes the operational planning reality at Haven Genk, a Belgian trimodal terminal, and compares it to the theoretical knowledge described in section 2. Section 4 discusses the design and computational results of a simulation study, based on Haven Genk data. This study aims to identify the impact of vessel size and number of vessels in use on general terminal efficiency. Finally, section 5 formulates conclusions and possible directions for future research.

2. PLANNING PROBLEMS OF A BARGE TERMINAL OPERATOR

The main task of a terminal operator consists of ensuring a smooth operation of the container transshipment process in order to reduce the operational costs and increase the competitiveness of the terminal.

In a barge terminal, five subprocesses may be distinguished in the transshipment of containers. First, the vessel arrives at the terminal and moors at a specific berth. Freight containers need to be loaded and unloaded from the vessel making use of quay cranes. Next, the unloaded containers are transferred to stacks, which are covered or uncovered terminal areas where containers can be stored for a certain amount of time. Finally, containers are retrieved from their stacks and transported to other transport modes like trucks, trains or vessels to complete their journey to the final customer (Vis and de Koster 2003).

The efficiency with which these subprocesses are executed is greatly determined by the way the terminal operator handles planning problems associated with them. Caris et al. (2008) make a distinction between three temporal levels of planning related to the functioning of a transshipment terminal. The strategic level considers long term planning (ten to twenty years) and involves the highest management level as it concerns large capital investments over long time horizons. On a medium time level (months or weeks), tactical planning arises with the purpose of enhancing the general system performance through ensuring an efficient and rational resource allocation. Finally, short term (daily or real-time), operational planning involves decisions in a highly dynamic environment made by local management.

Taking into account the above factors associated with terminal operator planning, two classification matrices can be created for his operational problems. In general, a distinction can be made between two problem categories, coinciding with two different matrices. On the one hand, the terminal operator is confronted with various general planning problems on the three temporal levels associated with the transshipment terminal. On the other hand, specific planning problems linked to the different subprocesses in container transshipment can be identified, again on the strategic, tactical and operational levels. Both matrices, presented in Tables 4 and 5 which can be found in Appendices A and B respectively, will be briefly described in the following paragraphs.

2.1. General terminal operator planning problems

The first category of planning problems constitutes challenges which are not exclusively associated with barge terminals. Table 4 presents an overview of these problems, based on the articles by Caris et al. (2008) and Macharis and Bontekoning (2004).

On a **strategic level**, the terminal operator needs to decide on the design of his intermodal terminal. Design decisions concern, among others, the type and capacity of terminal facilities, the general way of employing material and labor in the transshipment process and the overall lay-out of the terminal (Macharis and Bontekoning 2004). When making a terminal design choice, the operator can opt for an own design adapted to his specific intermodal needs or a design suggested in scientific literature with a record of proven performance. In any case, the decision needs to be well-considered as the final design has a significant impact on the efficiency with which a container goes through the different transshipment subprocesses.

Concerning **tactical planning**, a terminal operator has two important tasks. First, he needs to determine the required capacity levels of material and labor resources, a decision which can be made separate from or together with the identification of the appropriate terminal design. A second tactical planning problem is twofold and consists of the design of operational routines, like operating strategies for quay cranes, on the one hand

and the determination of specific terminal layout structures on the other hand.

Finally, on the **operational level**, the terminal operator needs to decide how terminal resources (material and labour) will be allocated to the different tasks that need to be performed. More specifically, it concerns the planning of which material infrastructure and number of employees are to be assigned to a certain sequence of labour shifts (Zaffalon et al. 1998). Secondly, the terminal operator has to establish a daily planning of terminal jobs which maximises operational efficiency.

2.1.1. Solution approaches

Reviewing current scientific literature on general terminal operator planning problems, a distinction may be made between optimisation techniques on the one hand and simulation studies on the other hand.

These two distinct solution procedures may also be associated with specific temporal problem levels. As such, it turns out that simulation is the most applied method to solve the strategic problem of terminal design (e.g. Ferreira and Sigut 1995; Rizolli et al. 2002). The choice might be explained because simulation provides the opportunity to model the entire terminal and handle several design issues simultaneously. When solving a tactical problem, the use of simulation versus optimisation techniques may be equally divided (e.g. Kim et al. 2008; Martinez et al. 2004). The choice of solution procedure depends on the preferences of the terminal operator and the distinct characteristics of the terminal. Finally, when looking at operational decisions, the majority of scientific articles suggests the use of optimisation techniques (e.g. Gambardella et al. 2001; Kim et al. 2004).

2.1.2. Performance measures

Besides used solution methods, a distinction may also be made between three general categories of performance measures suggested in current literature on general terminal operator planning problems.

A first category is associated with time. Frequently mentioned time measures within the scope of terminal operator planning problems include: total time needed for (un)loading containers, service times or waiting times of trains/trucks/vessels and total container throughput time. Costs make up a second group of performance measures. Important cost factors associated with terminal operator planning include: crane working costs, transportation costs, container handling costs and labour costs. A final performance measure regularly used to evaluate the efficiency of terminal operations relates to the utilisation of resources (cranes, vehicles, stack locations...).

2.2. Planning problems per subprocess

A barge terminal operator is confronted with several planning difficulties in the various subprocesses of container transshipment. These are presented in Table 5,

an outline based on the article by Vis and de Koster (2003).

A first decision that the terminal operator needs to make in the context of a loaded **vessel arrival** on a strategic level is the identification of the number of available berths. For this purpose, a trade-off needs to be made between the investment in additional berths and longer waiting times for arriving vessels (Alattar et al. 2006). Once the terminal operator has decided on the number of berths, he has to allocate arriving vessels to these berths on a daily level.

In a next phase, **containers** need to be **(un)loaded from the moored vessel**. Strategically, the terminal operator has to decide on the type of material to use for this task. Vis and de Koster (2003) state that quay cranes are the most commonly used equipment for the (un)loading job. On a tactical level, the operator needs to determine how many cranes will be employed simultaneously to (un)load a single vessel. As Vis and de Koster (2003) suggest, it is important to perform the (un)loading task as fast as possible in order to minimise waiting times of vessels and comply with the service required by customers. Then, on an operational basis, the terminal operator has to create a detailed (un)loading plan which specifies the precise (un)loading sequence of containers, next to each container's specific position on the vessel (Shields 1984).

When containers are unloaded from the vessel, they need to be **transported from vessel to stack** to be stored there for a certain amount of time. A strategic decision, similar to the one in the (un)loading subprocess, is the determination of the type of vehicles to be used for internal container transport. Possible alternatives the terminal operator can choose from include straddle carriers, forklift trucks, yard trucks or any kind of automated guided vehicle (Vis and de Koster 2003). Once the appropriate vehicles are chosen, the terminal operator needs to identify the necessary number of these transportation vehicles on a tactical level. Finally, on a daily basis, he has to establish a detailed container transport plan. This plan defines which vehicle transports which container and which routes are chosen for this internal transport. These problems can be classified as routing and scheduling problems.

Arriving at the stack, **containers** need to be **stored** for a certain amount of time. The stack may be divided in various blocks or lanes each consisting of a number of container rows. The height of the stack varies according to the available facilities at the terminal (Vis and de Koster 2003). On a strategic level, analogue with the previous phases, a decision needs to be made on the materials used for container stacking. Facilities like forklift trucks, reach stackers, yard cranes and straddle carriers are most commonly used in practice for this job. Next, the terminal operator has to think strategically about the best strategy to stack the containers. This should be a well thought through decision since the way containers are stacked has a significant impact on the efficiency of the following phases of transshipment. A

decision associated with the stacking strategy is the determination of the optimal stack configuration. A trade-off should be made between minimal container handling and an optimal use of available stacking space (Decastilho and Daganzo 1993). On a tactical level of the stacking process, the terminal operator has to determine how many cranes or straddle carriers are needed to ensure efficient stacking. On an operational level, the detailed route of container stacking facilities throughout the stack needs to be planned. This plan describes the sequence of lanes the stacking vehicle follows and the number of containers stored in each lane (Kim and Kim 1997).

In the last phase of the transshipment process, containers are **transported from the stack to other transport modes** like train, truck or vessel. Strategically, the operator has to decide on vehicles used for this transport. In this context, Vis and de Koster (2003) suggest employing multi-trailer systems or automated guided vehicles. The terminal operator may also choose to perform this type of transport with the same infrastructure used for the (un)loading subprocess. A trade-off has to be made between making additional investments or accruing additional vehicle waiting times.

2.2.1. Solution approaches

Also for planning problems per subprocess a distinction may be made between the use of optimisation techniques and simulation studies. However, the use of simulation is much less evident in this context. Simulation may be used in combination with optimisation techniques to validate the generated solutions.

When looking in detail at optimisation techniques to solve the various planning problems per subprocess, it appears that the majority of scientific papers suggests the combination of two methods. In many cases, the planning problem is formally modelled and defined as a specific mathematical programming problem which is then solved with an appropriate (meta)heuristic (e.g. Kozan and Preston 1999; Sammarra et al. 2007).

2.2.2. Performance measures

A distinction may be made between three categories of performance measures giving an indication of terminal efficiency.

A first category of measures is associated with time. Important time elements that may be linked with transshipment planning are: waiting or service times of vessels/containers, amount of idle time of cranes/container transport vehicles, (un)loading time and container vehicle travel time. A second category of performance measures are those related to costs. Frequently mentioned cost measures within the scope of terminal operator planning problems are: general waiting costs and fixed or variable costs associated with cranes or container transport vehicles. Finally, some other measures regularly used to evaluate the transshipment process are: utilisation of

quays/cranes/vehicles/stack locations, service priorities related to vessels/containers, barge stability, number of container movements and vehicle travel distance.

3. A BARGE TERMINAL IN PRACTICE: HAVEN GENK N.V.

In order to verify the findings from the literature review described in section 2, the general operations of the trimodal terminal Haven Genk N.V., lying in the hinterland of the Port of Antwerp, have been observed for several days. Haven Genk N.V. is a strategically located and fully equipped trimodal terminal performing not only traditional transport and transshipment activities, but also offering its customers additional services like stuffing, stripping and forwarding activities (Haven Genk 2012).

Through the combination of real terminal information, acquired via observation and employee testimonies, and conclusions drawn from current scientific literature, knowledge on barge terminal operations could be significantly refined and deepened. The remainder of this section is organised as follows. In a first paragraph, the main characteristics of Haven Genk's barge planning are explained. Secondly, a direct link is made between the theoretical planning problems found in the classification matrices and operational reality at the trimodal terminal of Genk.

3.1. Barge planning at Haven Genk

Haven Genk mainly transports containers to the Port of Antwerp according to a fixed service schedule of four departures every week. For this transport, Haven Genk may choose to use its own vessel, use a vessel owned by a partner organisation or hire a section on a vessel owned by a broker company.

Two important factors are influencing the barge planning at Haven Genk. First, scheduling of barge container transport is customer driven. When a customer submits a request to transport a certain amount of containers, Haven Genk compares the offers of various shipping companies and chooses the appropriate one according to measures of time or price, depending on the required customer service level. Second, barge planning at Haven Genk strongly depends on decisions made by sea terminal operators at the Port of Antwerp. Haven Genk needs to make separate appointments with these operators, owning several quays at the Port of Antwerp, if it wants a vessel to moor at one of these quays during a specific time slot. Requests to moor need to be submitted at least two days before barge arrival and the seaport terminal operators have the final say in the approval.

3.2. Comparison between theory and practice

This section links the literature review concerning terminal operator planning problems to the way these challenges are handled in real-life at Haven Genk. The goal is to identify possible gaps and overlaps which may point at improvement opportunities in the operations of intermodal barge terminals.

Concerning this comparison, some general remarks may be made. First, not all planning problems mentioned in the classification matrices are handled again in this paragraph. The reason for this fact is that not all planning problems suggested in literature are considered of equal importance in practice. Some planning issues are handled in an automatic fashion at Haven Genk without much thought or modelling work. An example of such a routine practical planning problem is the operational routing and scheduling of container transport vehicles. These routing decisions are taken ad hoc by the vehicle operators themselves on the basis of their experience and intuition. Second, from the employee testimonies and observation results at Haven Genk, it became clear that, in reality, barge planning is scarcely supported by scientific models and methods. More than once, employees emphasised that all decisions need to be made in a dynamic context. It is difficult to create appropriate theoretical models as these cannot account for the various internal and external situations the terminal may be confronted with. For these reasons, improvisation and continuous reflection are two concepts Haven Genk strongly believes in.

3.2.1. General terminal operator planning problems

Considering **terminal design** in practice, the general terminal lay-out evolves on the basis of projects, always taking into account available terminal space. On the contrary, literature suggests the use of theoretical models to determine the optimal location of facilities. A possible explanation for this difference is the fact that models suggested in literature are developed for terminals focusing exclusively on container transshipment. Therefore, the design of Haven Genk, a trimodal terminal offering an entire set of logistical services, cannot be handled this straightforward and will eventually develop depending on projects and contracts the terminal engages in.

On a tactical level, the terminal operator needs to decide on **capacity levels**. The performance measure Haven Genk focuses on when taking this decision is the processed container volume at the terminal. The terminal operator monitors whether the terminal has sufficient material and labour capacity at its disposal to handle the requested demand volume. Only when the benefits of transporting containers using own resources can compensate for additional investments, the terminal operator will decide to acquire additional infrastructure. This statement may be proved with the fact that Haven Genk has reduced its vessel fleet in 2010 to a single vessel as a consequence of the strong decline in barge transport volumes. Comparing this volume based approach with the theoretical solutions to capacity identification as suggested in scientific literature, it may be noted that the use of theoretical models to decide on capacity levels is justified only when transport volume is sufficiently high.

3.2.2. Planning problems per subprocess

In practice, the entire process of container transshipment from arrival of the vessel to transportation of containers to other transport modes is strongly customer driven. The customer determines the required service level and as such the performance measures Haven Genk has to take into account in the planning of container transshipment. Secondly, the trimodal terminal is rather dependent on the Port of Antwerp for the establishment of its barge planning. This dependence has an impact on the way the trimodal terminal approaches its transshipment process. Finally, waiting time appears to be a crucial performance measure for Haven Genk in all of the transshipment phases. It is therefore of key importance to organise and perform all of the subprocesses as efficient as possible in order to reduce these waiting times and their associated costs to a minimum.

Considering the **arrival of vessels** at the terminal, an operational decision relevant in the context of the trimodal terminal is the allocation of these barges to the available berths. As Haven Genk has only one quay at its disposal, this planning problem is not an issue. However, terminal operators at the Port of Antwerp need to make this decision. When Haven Genk contacts them to (un)load a certain amount of containers, they have to decide which quay is most suited for this job. This decision depends on the shipping company taking care of the container transport. Additionally, they also take into account the sequence in which containers need to be (un)loaded so as to minimise waiting times. This practical approach to vessel allocation has some important overlaps with solution methods suggested in scientific literature. First, waiting time is considered an important performance measure both in practice and in theory. Theoretical models and practical allocations both strive to minimise the time a vessel spends at a terminal. Second, vessel allocation is often a customer driven decision. This customer focus is expressed in literature through the use of service priorities, while Haven Genk mainly looks at customer provided time windows to (un)load a vessel.

A strategic decision related to almost all subprocesses is the choice of appropriate infrastructure to perform the respective transshipment task. Concerning the **loading and unloading of a vessel**, Haven Genk has two quay cranes at its disposal, mainly used for (un)loading containers. In addition, the terminal has three hydraulic cranes and three bulldozers to load and unload bulk cargo. On an operational level, the terminal operator has to establish a container load plan which specifies the sequence in which containers are loaded and unloaded from the vessel. This plan is strongly influenced by the time windows and quays Haven Genk is assigned to by sea terminal operators in the Port of Antwerp. The specific location of a container on the vessel is a decision made by the captain of the vessel, as opposed to what is suggested in scientific literature.

Then, containers need to be **transported to the stack** where they are stored for a certain time period.

Haven Genk employs reach stackers to perform this internal container transport. These vehicles can stack containers up to five rows high, as opposed to straddle carriers, which can only stack containers up to two high.

Next, Haven Genk **stacks containers** on the basis of their characteristics. Containers are grouped in stack lanes on the basis of their destination, the quay they need to be unloaded on or the shipping company taking care of their further transportation. The goal of this stacking strategy is to minimise container rehandling during their loading on another transport mode.

4. SIMULATION STUDY

4.1. Introduction

Combining our findings from literature with the observations at Haven Genk leads to the conclusion that it is essential to approach the various terminal operator planning problems as careful and well-considered as possible in order to guarantee optimal functioning of the terminal. Concerning the solution methods to these planning problems, theory and practice suggest a wide variety of procedures. Simulation is a technique often used in the context of container terminals. As defined by Hassan (1993), simulation is a scientific methodology to study a complex environment like a multimodal terminal.

Simulation of the transshipment process of containers in a barge terminal is an effective method to study the various planning problems terminal operators are challenged with in this context. Simulation creates the opportunity to study the efficiency of the various transshipment subprocesses under varying conditions using a simplified terminal model. In addition, it becomes possible to define the factors influencing terminal operations in an artificial reality. The processes in a container terminal may be reviewed without accruing high costs or making permanent changes to the current terminal. Moreover the various planning problems on all temporal levels (strategic, tactical and operational) may be studied simultaneously and scenarios may be developed to answer 'what-if' questions concerning transshipment planning (Nomden 2007).

The purpose of the following paragraphs is to apply discrete event simulation to the barge terminal of Haven Genk. Section 4.2 briefly describes the translation of the Haven Genk barge terminal operations into a simulation model fit for Arena software. Next, section 4.3 develops various simulation scenarios concerning used materials or infrastructure and processed container volumes on the basis of theoretical findings and practical suggestions. The goal is to examine whether adaptations in vessel sizes and number of used vessels have an impact on terminal efficiency under various container volumes. Replication parameters and studied performance measures are outlined in section 4.4.. Finally, section 4.5 describes the main results of the simulation study and formulates recommendations to Haven Genk in order to improve

its transshipment efficiency and its anticipation capability to changing container volumes.

The simulation study described in the following subsections proposes a first, simplified implementation of the barge terminal operations at Haven Genk. However, the suggested model may provide an incentive for future refined simulation applications as described in the ‘future research’ paragraph of section 5.

4.2. Simulation model: Haven Genk barge terminal

The operations of the Haven Genk barge terminal may be described by means of the different phases a container goes through in the transshipment process. For export containers, which reach the terminal by truck or via rail and leave the terminal by barge, the following steps may be distinguished. When the container arrives at the terminal via the landside, it is identified through the registration of data like container content, destination, shipment company and barge to be loaded on. In a next phase, the container is transported with the use of a reach stacker to the appropriate lane in the stack. Finally, when the container’s destination vessel has arrived, it is retrieved from the stack and loaded on this vessel to continue its journey to its destination. The phases in the transshipment process of an import container, reaching the terminal by barge and leaving it via the landside, are similar to those of an export container but in reverse order. Both processes run simultaneously in every barge terminal (Günther and Kim 2006).

The Arena flow diagram in Appendix C represents the different phases of transshipping an import container, starting with the arrival of the loaded vessel at the terminal and ending with the container pursuing its trajectory over land. Its various building blocks associated with the different transshipment phases will be described below. Containers are considered as the entities in the system.

The first four blocks of the diagram represent the arrival of import containers at the terminal by barge. Container arrival times, based on real Haven Genk data, are read from a Microsoft Excel file. Next, the created container entities are unloaded from their respective vessels. For this purpose, a Process module is used which represents a quay crane seizing a container and releasing it after some time in the stack zone. Since the length of time spent in the stack differs for full and empty containers, a Decide module is inserted to make sure that 78% of all stacked import containers are full and 22% are empty. After a certain time period the appropriate containers are loaded onto their respective landside transport modes like trucks or trains making use of a reach stacker. Finally, the import containers leave the system to pursue their trajectory over land to the end customer. The transshipment of export containers, starting with the arrival of containers at the terminal by train or truck and ending with leaving the terminal by barge, can be described and modelled in a similar, but reversed, way.

The main **assumptions or inputs** applicable in both parallel, simultaneous transshipment processes are the following. At first, assumptions made for the *import container transshipment process* are described. To start with, an arrival rate needs to be determined for vessels unloading their import containers at the barge terminal. For this task, Haven Genk disposes of two 154 TEU vessels each arriving two times a week at the barge terminal. These vessels are used in cooperation with the transshipment terminal of Liège to an average capacity of 104 TEU, meaning that containers are stacked in two rows. The remaining 50 TEU, corresponding to a third layer of containers, is used as a buffer to cope with demand peaks. An annual average of 12500 TEU can be allocated both to the transshipment process of import containers and to the transshipment process of export containers, which corresponds to 240 TEU weekly or 60 TEU every arrival day. This amount of 60 TEU is considerably lower than the 104 TEU vessel capacity. An explanation for this difference is that the remaining space on the barge is used by containers from the Liège terminal. Secondly, a distribution has to be determined for the import container unloading time. In this context, Haven Genk stated that quay cranes are capable of unloading 17 containers in one hour. Next, in the stacking Process modules for full and empty containers a distribution needs to be identified for the time containers spend in the stack. Based on Haven Genk information, a Triangular Delay Type is chosen here with minimal, modal and maximal values for the stacking times of full and empty containers respectively. Finally, import containers are loaded on trucks or trains making use of reach stackers. Similar to the unloading process, a Constant Delay Type is chosen here, now with an average value of 2.86 minutes since reach stackers are more flexible than quay cranes. An additional assumption made in the context of *export container transshipment* is the determination of the arrival rates of trucks and trains transporting containers to the barge terminal via the landside. As already mentioned above, an export container volume of 240 TEU is processed every week at the terminal. Considering the fact that trucks and trains transport containers to Genk every workday, an average of 48 TEU can be allocated to Monday, Tuesday, Wednesday, Thursday and Friday.

4.3. Simulation scenarios

For the purpose of analysing barge terminal efficiency under various circumstances, three general scenarios with different vessel sizes and number of available vessels are created. In addition, for each of these scenarios an optimistic and pessimistic subscenario is considered regarding the processed container volume.

4.3.1. Baseline scenario

The baseline scenario corresponds to the current situation of Haven Genk. Barge transport is performed by two vessels of 154 TEU each, of which 104 TEU is used effectively to stack containers and 50 TEU serves

as a buffer against demand fluctuations. Concerning container volume, Haven Genk processes 25000 TEU annually meaning that a weekly average of 240 TEU can be allocated to import containers and export containers respectively. The other inputs of this scenario are described in paragraph 4.2..

In an optimistic subscenario the current vessel fleet is kept unchanged, while the processed container volume increases to 40000 TEU annually, a rise of 60% with regard to its current level. This choice of 40000 TEU is based on Haven Genk data concerning expected future developments in barge transport container volumes. In a pessimistic scenario, again maintaining the current fleet size, a decline of the processed container volume to 20000 TEU (-20%) is considered.

4.3.2. Scenario A

In this scenario one of the 154 TEU vessels is replaced by two 60 TEU vessels. In this way, the terminal has three vessels at its disposal to transport containers by barge. The current annual container volume of 25000 TEU remains unchanged. The only simulation input changes needed to run this scenario pertain to the arrival rates of containers. Considering import containers, the availability of three vessels creates the opportunity to provide customers with a service of six departures every week instead of the current level of four. This leads to the following weekly barge planning for Haven Genk:

Table 1: Barge Planning Import Containers Scenario A

Day of the week	Arriving vessel size	Loaded TEU volume
Monday	104 TEU	55 TEU
Tuesday	60 TEU	33 TEU
Wednesday	60 TEU	33 TEU
Thursday	104 TEU	55 TEU
Friday	60 TEU	32 TEU
Saturday	60 TEU	32 TEU

Regarding this barge planning, barge utilisation is significantly lower than its capacity level. The explanation for this fact is that the remaining vessel stacking space is used by containers transported by the Liège terminal working in cooperation with Genk.

In an optimistic subscenario the three vessels of scenario A are maintained, while the processed container volume increases to 40000 TEU annually. This leads to the conclusion that, as a consequence of the increased container volume, the 60 TEU vessels can no longer be used in cooperation with the Liège terminal. In addition, the average utilisation of the 154 TEU vessel is now raised to the total 154 TEU, thus losing the buffer, in order to make cooperation and sharing of costs for this vessel still possible. In a pessimistic scenario, maintaining the fleet size of three, a reduction of the processed container volume to 20000 TEU is considered.

4.3.3. Scenario B

In this scenario one of the 154 TEU barges is replaced by only one 60 TEU barge to find out if this limited fleet size can cope with various container volumes. The current annual container volume of 25000 TEU remains unchanged. The only simulation input changes needed to run this scenario pertain to the arrival rates of import containers. As the terminal disposes of two vessels like in the basic scenario, a service of four departures every week can be provided to customers. This situation leads to a four day allocation of 60 TEU container volume. As a consequence, the 60 TEU vessel cannot be operated in cooperation with the Liège terminal as Haven Genk will need the entire barge stacking space to cope with current customer demand.

In an optimistic subscenario both vessels of scenario B are maintained, while the processed container volume increases to 40000 TEU annually. This leads to the conclusion that, as a consequence of the increased container volume, neither the 60 TEU barge nor the 154 TEU barge can be used in cooperation with the Liège terminal. In addition, the average utilisation of the 154 TEU vessel is now raised to the total 154 TEU, thus losing the buffer, to cope with the rising demand level. In a pessimistic scenario, maintaining the fleet size of two, a reduction of the processed container volume to 20000 TEU is considered.

4.4. Replication parameters and performance measures

To obtain a sufficiently realistic picture of the actual functioning of a barge terminal and to guarantee stable simulation results, it is necessary to run the study over a significant period of time, in this case over a period of 10 weeks. Each week is simulated separately, accounting for the number of remaining containers from the previous week, and can thus be considered a single model replication with a replication length of 7 days. In this way, simulation results can be compared over a period of 10 weeks and it becomes possible to draw realistic conclusions regarding the values of performance measures in each of the simulation scenarios.

The performance measures to determine the effect of varying vessel types, fleet sizes and container volumes on the general barge terminal efficiency are the following. First, the utilisation rates of the resources quay crane, reach stacker and stack locations are examined. Next, the total container throughput time and its time spent in the various subprocesses of transshipment is investigated. Finally, a trade-off is made between customer service, in terms of vessel departure frequency, and the costs of employing the available vessel fleet.

4.5. Main simulation results and discussion

This paragraph describes the main results of simulation analyses performed on the three scenarios and formulates some recommendations to Haven Genk

concerning used vessel sizes and number of vessels to ensure optimal barge terminal functioning.

4.5.1. Simulation results

The main simulation results are presented in Table 2. First, it can be concluded that the relevant performance measures ‘resource utilisation’ and ‘container throughput time’ are not significantly influenced by the fleet changes. Secondly, analysing the effects of positive and negative container volume changes demonstrate that resource utilisation is affected in a linear way by the processed volume. For example, the utilisation degree of both quay cranes and reach stackers increases with 60% when the container volume rises with the same percentage in all three studied scenarios. On the contrary, the terminal efficiency measure of container throughput time remains unchanged under varying container volumes.

Table 2: Main Simulation Results

	Resource utilisation		Container throughput time
	Quay crane	Reach stacker	
Basic scenario	17%	14%	70 hours
Basic scenario opt	27%	22%	70 hours
Basic scenario pess	14%	11%	70 hours
Scenario A	17%	14%	70 hours
Scenario A opt	27%	22%	70 hours
Scenario A pess	14%	11%	70 hours
Scenario B	17%	14%	70 hours
Scenario B opt	27%	22%	70 hours
Scenario B pess	14%	11%	70 hours

Additionally some general remarks may be made for the simulation analysis outcomes. First, concerning the utilisation of stack locations, results show that they are significantly lower than the available capacity of 20000 TEU. The explanation for this outcome is that the simulation model only accounts for containers transported by barge. The numerous containers transported by truck or train only, which are also temporarily stored in the stack, are not included in our model. Second, the resources ‘quay crane’ and ‘reach stacker’ are underused with utilisation degrees under 30%. For the reach stacker the explanation may be found again in the simplifications made in this simulation study. Since Haven Genk in reality uses the reach stacker for other purposes than container transshipment, it can be expected that the simulation utilisation degree is below the realistic level. The low utilisation of the quay crane cannot be explained, since Haven Genk uses this resource exclusively for (un)loading vessels and all containers transported by barge were included in the model. Finally, from the analysis of the container throughput time, it turns out that more than 90% is due to one subprocess in container transshipment, namely container storage in the

stack. Time spent in the stack has a significant impact on general terminal efficiency.

4.5.2. Recommendations to Haven Genk

Considering the fact that the applied vessel changes appeared to have no significant influence on the barge terminal efficiency in terms of container throughput time and resource utilisation, Haven Genk may be advised to focus on the service-cost relation when deciding on available fleet sizes. Comparing this relation for the three scenario’s (Table 3), the following recommendations can be formulated. If Haven Genk opts for a reinforcement of its customer focus, the terminal operator can choose to replace one 104 TEU vessel with two 60 TEU vessels (scenario A) as this leads to a 50% rise in service level. However, this service level increase is also associated with a 42.5% rise in costs. Accordingly, when the service level increase of 50% cannot produce sufficient returns to compensate for those increased costs, it is best to relinquish scenario A. In that case, Haven Genk should execute scenario B to acquire the best results since this scenario preserves the current service level without any efficiency losses while costs diminish with 4%.

Table 3: Service-Cost Relation in Three Scenarios

	Service level	Cost level (weekly vessel cost + fuel cost)
Basic scenario	4 departures/week	€24092
Scenario A	6 departures/week	€34338
Scenario B	4 departures/week	€23192

Regarding the low utilisation level of the quay crane, it is best Haven Genk performs a thorough investigation to find out its cause in order to ensure terminal efficiency. Finally, since the container throughput time mainly consists of time spent in the stack, Haven Genk should focus on reducing storage times when working towards lower container transshipment times.

5. CONCLUSIONS AND FUTURE RESEARCH

To reinforce the competitive strength of intermodal transportation in its strife against unimodal road transport, it is essential to organise terminal operations as efficient and effective as possible. Investigating the operations of intermodal barge terminals in theory and practice is therefore the central research question in this paper.

From a thorough review of current barge terminal literature, it became clear that the terminal operator’s approach to the various planning problems in container transshipment has a significant impact on terminal cost and time levels. A comparison of literature findings with the operations at Haven Genk, a Belgian trimodal terminal, leads to the conclusion that not all theoretic planning problems are considered equally relevant in practice. In addition, it became clear that barge planning

could be supported with theoretical models only in a limited way as terminals operate in a very dynamic environment where improvisation and continuous reflection are important concepts. Finally, a simulation study was developed to investigate whether variations in vessel sizes, fleet sizes and container volumes had a significant effect on terminal efficiency. An analysis of the simulation results showed that the relevant performance measures were not significantly affected by the applied fleet size changes. As a consequence, Haven Genk focuses best on service-cost relations when deciding on used vessel types. In addition, it turned out that changing container volumes influenced resource utilisation in a linear way and container throughput time is mainly caused by the stacking subprocess.

The study on terminal operations described in this paper leaves some opportunities for future research. A first opportunity is to investigate the planning problems other transportation network actors, like drayage, network and intermodal operators, are confronted with. Secondly, when exploring barge terminal operations, the focus may be expanded from considering container transshipment exclusively to accounting for additional services like bulk transshipment, stuffing and stripping services or forwarding activities. It could be useful to explore whether these additional tasks have a significant impact on terminal efficiency. Moreover, besides barge transshipment operations also truck and train transshipment could be included. Finally, as the simulation study showed that the applied vessel changes did not influence performance measures considerably, another possible direction for future research could be to create additional simulation scenarios. These scenarios could contain modifications in number of used quay cranes/reach stackers or in terminal lay-out. Considering Haven Genk's relationship with the Port of Antwerp another possibility is to create coordination/dependency scenarios integrating both actors. Finally, it could be useful to perform a sensitivity analysis to find out in which cost ranges (fixed vessel costs and fuel costs) the current advices on fleet sizes remain valid.

ACKNOWLEDGMENTS

The authors are very grateful for the valuable assistance they received from all the members of staff and in particular the General Manager Mr. Donders L. of Haven Genk. Thanks are in order for providing the opportunity to study transshipment terminal operations from a practical, real-life viewpoint.

APPENDICES

Appendix A

Table 4: General Terminal Operator Planning Problems

Strategic	Time horizon	
	Tactical	Operational
Terminal design	Identification of material and labour capacity levels	Resource allocation
	Design of operational routines and layout structures	Job scheduling

Appendix B

Table 5: Terminal Operator Planning Problems per Subprocess

Subprocess in transshipment	Time horizon		
	Strategic	Tactical	Operational
Arrival of the vessel	Identification of number of needed berths		Allocation of vessels to berths
(Un)loading of the vessel	Selection type of material for (un)loading	Identification of optimal number of quay cranes	Establishing appropriate load plan
Transport of containers to stack	Selection type of material for transport	Identification of optimal number of container transport vehicles	Establishing container transport planning
Stacking containers	Selection type of material for stacking	Identification of optimal number of transfer cranes for stacking process	Optimal routing straddle carriers throughout the stack
	Identification of optimal stacking strategy		Establishing sequence in which containers are retrieved from the stack
	Identification of optimal stack configuration		
Transporting containers to other transport modes	Selection of appropriate transport systems		

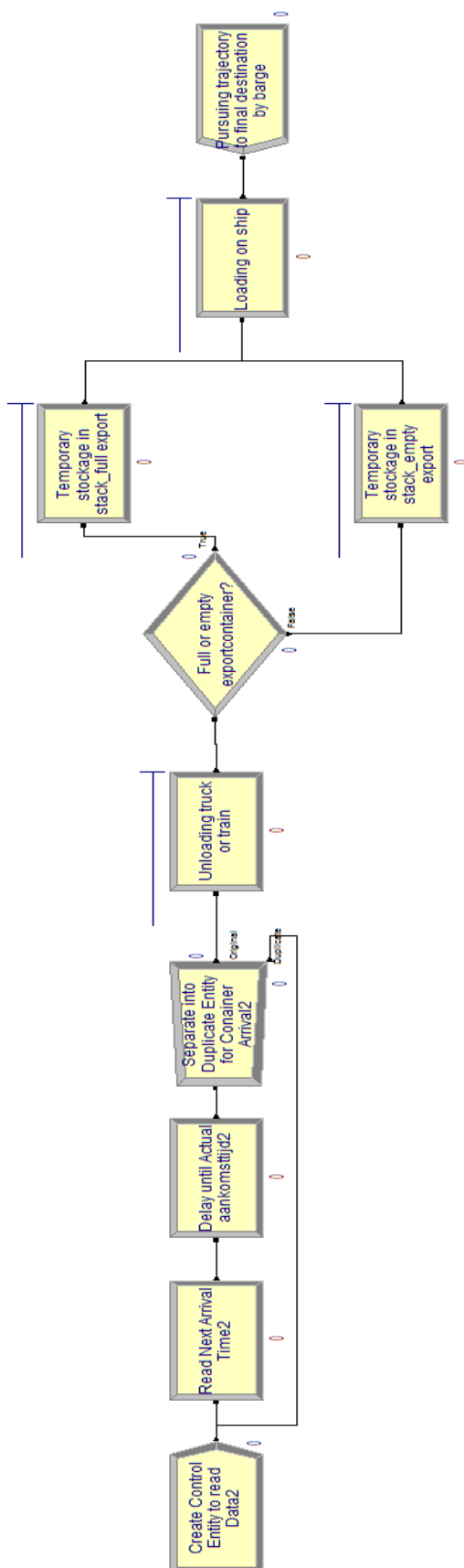

Figure 1: Import Container Transshipment in Arena

REFERENCES

Alattar, M.A., Karkare, B., Rajhans, N., 2006. Simulation of container queues for port investment decisions. *Proceedings of the 6th International Symposium on Operations Research and its Applications*, pp. 155-167. August 8-12, Xinjiang (China).

Caris, A., Macharis, C., Janssens, G.K., 2008. Planning problems in intermodal freight transport: accomplishments and prospects. *Transportation Planning and Technology*, 31(3), 277-302.

Decastilho, B., Daganzo, C.F., 1993. Handling strategies for import containers at marine terminals. *Transportation Research Part B: Methodological*, 27(2), 151-166.

Ferreira, L., Sigut, J., 1995. Modelling intermodal freight terminal operations. *Road and Transport Research Journal*, 4(4), 4-16.

Gambardella, L.M., Mastrolilli, M., Rizzoli, A.E., Zaffalon, M., 2001. An optimization methodology for intermodal terminal management. *Journal of Intelligent Manufacturing*, 12(5-6), 521-534.

Günther, H.O., Kim, K.H., 2006. Container terminals and terminal operations. *OR Spectrum*, 28(4), 437-445.

Hassan, S.A., 1993. Port activity simulation: an overview. *ACM SIGSIM Simulation Digest*, 23(2), 17-36.

Haven Genk, 2012. *Haven Genk N.V.* [Dutch (Belgium)]. Available from: <http://www.havengenk.be/> [accessed 20 January 2012].

Kim, K.H., Kim, K.W., Hwang, H., Ko, C.S., 2004. Operator-scheduling using a constraint satisfaction technique in port container terminals. *Computers & Industrial Engineering*, 46(2), 373-381.

Kim, K.H., Park, Y.M., Jin, M.J., 2008. An optimal layout of container yards. *OR Spectrum*, 30(4), 675-695.

Kim, K.Y., Kim, K.H., 1997. A routing algorithm for a single transfer crane to load export containers onto a containership. *Computers & Industrial Engineering*, 33(3-4), 673-676.

Konings, R., Bontekoning, Y., Maat, K., 2006. De concurrentiekracht van intermodaal vervoer in ruimtelijk perspectief: Intermodaal op welke schaal? [Dutch (Belgium)]. In: Despontin, M., Macharis, C., eds. *Mobiliteit en (groot)stedenbeleid; 27e Vlaams Wetenschappelijk Economisch Congres*. Brussels: VUBPRESS (Politeia), 181-205.

Kozan, E., Preston, P., 1999. Genetic algorithms to schedule container transfers at multimodal terminals. *International Transactions in Operational Research*, 6(3), 311-329.

Macharis, C., Bontekoning, Y.M., 2004. Opportunities for OR in intermodal freight transport research: a review. *European Journal of Operational Research*, 153(2), 400-416.

- Macharis, C., Verbeke, A., 1999. *Intermodaal vervoer: economische en strategische aspecten van het intermodaal vervoer in Vlaanderen*. Dutch (Belgium). Leuven/Apeldoorn: Garant.
- Martínez, F.M., Gutiérrez, I.G., Oliviera, A.O., Bedia, L.M.A., 2004. Gantry crane operations to transfer containers between trains: a simulation study of a Spanish terminal. *Transportation Planning and Technology*, 27(4), 261-284.
- Nomden, G., 2007. *De opmars van simulatie in logistiek*. Logistiek: Nieuws, kennis en carrière. Dutch (Belgium). Available from http://www.logistiek.nl/experts/id1044-De_opmars_van_simulatie_in_logistiek.html [accessed 23 January 2012].
- Rizzoli, A.E., Fornara, N., Gambardella, L.M., 2002. A simulation tool for combined rail/road transport in intermodal terminals. *Mathematics and Computers in Simulation*, 59(1-3), 57-71.
- Sammarrá, M., Cordeau, J.F., Laporte, G., Monaco, M.F., 2007. A tabu search heuristic for the quay crane scheduling problem. *Journal of Scheduling*, 10(4-5), 327-336.
- Shields, J.J., 1984. Container stowage: a computer aided preplanning system. *Marine Technology*, 21(4), 370-383.
- Vis, I.F.A., de Koster, R., 2003. Transshipment of containers at a container terminal: an overview. *European Journal of Operational Research*, 147(1), 1-16.
- Zaffalon, M., Rizzoli, A.E., Gambardella, L.M., Mastrolilli, M., 1998. Resource allocation and scheduling of operations in an intermodal terminal. *Proceedings of the 10th European Simulation Symposium and Exhibition, Simulation in Industry*, pp. 520-528, October 26-28, Nottingham (United Kingdom).

AUTHORS BIOGRAPHY

Lotte Verdonck graduated as Master of Applied Economic Sciences: Business Engineer at Hasselt University, Belgium, in 2011. In October 2011, she started her Ph.D. research on which she will be working until 2015. This research mainly considers modelling freight consolidation from the perspective of transportation carriers.

An Caris is a postdoctoral researcher supported by the Research Foundation Flanders (FWO) at Hasselt University, Belgium. She received a Master degree in Business Economics with a major in Operations Management and Logistics at the Limburg University Centre (LUC), Belgium, in 2003. In 2010 she defended her Ph.D. in Applied Economic Sciences at Hasselt University, Belgium. Recently she is appointed as Assistant Professor of Operations Management and Logistics at Hasselt University within the Faculty of Business Administration. She takes a research interest in modelling intermodal freight transport networks, vehicle routing problems and metaheuristics.

Katrien Ramaekers graduated as Master of Business Economics at the Limburg University Centre, Belgium, in 2002. In 2007, she obtained her Ph.D. in Applied Economic Sciences at Hasselt University, Belgium. Her Ph.D. research concerned the integration of simulation and optimisation, especially as a support for complex logistics decision-making. Currently, she is a post-doctoral researcher at Hasselt University and is working on the modelling of freight transport.

Gerrit K. Janssens received degrees of M.Sc. in Engineering with Economy from the University of Antwerp (RUCA), Belgium, M.Sc. in Computer Science from the University of Ghent (RUG), Belgium, and Ph.D. from the Free University of Brussels (VUB), Belgium. After some years of work at General Motors Continental, Antwerp, he joined the University of Antwerp until the year 2000. Currently he is Professor of Operations Management and Logistics at Hasselt University within the Faculty of Business Administration. His main research interests include the development and application of operations research models in production and distribution logistics.