

2014•2015  
FACULTY OF BUSINESS ECONOMICS  
*Master of Management*

Master's thesis  
How Business Intelligence and BRMS bring benefits

Promotor :  
Prof. dr. Koenraad VANHOOF

Aida Hassanifar  
*Thesis presented in fulfillment of the requirements for the degree of Master of Management*

2014•2015  
FACULTY OF BUSINESS ECONOMICS  
*Master of Management*

# Master's thesis

## How Business Intelligence and BRMS bring benefits

Promotor :  
Prof. dr. Koenraad VANHOOF

Aida Hassanifar  
*Thesis presented in fulfillment of the requirements for the degree of Master of  
Management*



# How Business Intelligence and BRMS bring benefits!

## 1 CONTENTS

---

- 2 Preface..... 3
- 3 Dissertation research methodology ..... 5
- 4 What is Business Intelligence? ..... 7
  - 4.1 Business Intelligence definition..... 7
  - 4.2 The importance of BI ..... 7
- 5 Business Intelligence components ..... 9
  - 5.1 Data warehouse ..... 9
  - 5.2 Data sources ..... 9
  - 5.3 Data mart..... 10
  - 5.4 Query and reporting tools..... 10
- 6 Traditional Business Intelligence systems ..... 11
- 7 Real time Business Intelligence ..... 13
  - 7.1 How to move to Real time BI..... 13
- 8 BI and Descriptive, Predictive and Prescriptive analytics..... 15
- 9 Business Rules Management System (BRMS) ..... 17
  - 9.1 Decisions First Modeler ..... 17
  - 9.2 How effective BRMS and Decision Modeler could be in our organization ..... 18
  - 9.3 More flexible business applications ..... 19
  - 9.4 Decision Modeling for Predictive Analytics Projects ..... 20
  - 9.5 Decision Modeling for Business Intelligence Projects ..... 20
- 10 A case study by applying mix Business Process and Decision Modeling in a Logistic company 21
  - 10.1 Inbound process ..... 21
  - 10.2 Inbound Planning ..... 23
  - 10.3 Truck arrival & Dock allocation ..... 27
  - 10.4 Receiving ..... 29
    - 10.4.1 Business Process..... 29
    - 10.4.2 Decision Requirements..... 31
    - 10.4.3 Decision Logic ..... 34
    - 10.4.4 DMN Decision Tables: Quality Assessment Decision Table..... 34
    - 10.4.5 DMN Decision Tables: Inspection Plan Decision Table..... 36
    - 10.4.6 DMN Decision Tables: Receiving Decision Table ..... 41

10.5	DMN Decision Tables: Inbound Planning Decision Tables .....	44
10.6	DMN Decision Tables: Dock Allocation Decision Tables .....	45
11	what we have learned! What is the connection between those processes and decisions?.....	47
11.1	Can the decision modeler improve processes?.....	47
11.2	Are the processes guidelines for Decision discovery? .....	47
11.3	How DMN is connected to BPMN .....	47
11.4	Decisions First Modeling and Key Performance Indicators.....	49
11.4.1	Objective: IMPROVE PROCESSES TO ELIMINATE WASTE .....	50
11.4.2	Improved alignment .....	51
11.5	Increased capacity for change .....	51
12	Reference: .....	53

## 2 PREFACE

---

The objectives behind implementing BI initiatives are becoming increasingly apparent. The need for better decision-making is driving businesses to incorporate BI into day-to-day practices.

Although we see BI being pushed into mainstream business strategy, it's not considered an integral element yet. Figuring out how to make BI more prevalent is the challenge. We are going to help our audience to get a clearer image of BI in the real competitive world and understanding the essence of BI strategy within organizations by considering its significant advantages.

BI covers various analytical areas with innovative themes and engines such as: Dashboard, BI Reporting, BI predictive analytics, Data mining and etc.

But one of the major components of BI is BRMS which will be focused on in this paper. In BRMS by analyzing the information and rules stored in the information database, we are getting decisions, conclusions, recommendations and explanations as outputs. Furthermore, those outputs lead us to approach one of the major objectives of BI which is better decision making.

Then regarding BRMS we are going to introduce a new concept which is DMN (Decision Modeling Notation). Decision Management improves business rules design and implementation through the process of decision discovery and **decision modeling**. But modeling the business process is the first step before we can model the decisions. Next, by integrating process modeling and decision modeling we are going to build more effective processes. Furthermore throughout those steps in this study we will try to get the answer of our research sub questions as followed:

**Can the decision modeler improve processes?**

**Are the processes guidelines for Decision discovery?**

**Are decision and process logic independently discovered?**

**How does DMN help BI?**

**Can we be more agile and flexible by integrating process and decision logic?**

We are selecting supply chain environment to describe some of BI aspects in more tangible concepts.

The supply chain is a great place to use analytic tools and Business Intelligence to look for a competitive advantage, because of its complexity and also because of the prominent role supply chain plays in a company's cost structure and profitability. If we keep an open mind, we can always do better by digging deeper into data as well as by thinking about a predictive instead of reactive view of the data. By considering the apparent importance of supply chain in different business, this paper also tries to identify the need for decision modeling and BI in supply chain analytics. Enhancing efficiency of supply chain analytics with BI approach is vital elements in a company's ability to achieve its competitive advantage.

In general our methodology in this thesis is collecting data from different scientific resources to approach the answers of a set of sub questions with keeping our major concentration on our main research question: 'What kind of benefits could BI and BRMS bring to your company?'

### 3 DISSERTATION RESEARCH METHODOLOGY

---

In this paper we start to explore different aspects of BI and its main components in an organized framework. The main method used is secondary resources such as; scientific articles, papers, Book reviews and on line materials. Our main research domain is Business Intelligence, in more detail its components and particularly BRMS and DMN.

This study would also adopt a case study strategy in answering the research question. Robson (2002) asserts that the case study strategy would be useful if the aim of the study is to gain a rich understanding of the research perspective and the process being endorsed. Therefore as this study aims to understand the importance of BI role within organizations and a set of its significant advantages, a case study would be most effective.





## 4 WHAT IS BUSINESS INTELLIGENCE?

---

In recent years, decision support systems called business Intelligence (BI) have become an integral part of organization's decision making strategy. BI is the process of turning data into information and then into knowledge (Golfarelliet al., 2004). Organizations nowadays are competing in the global market. In order for a company to gain competitive advantage over the others and also to help make better decisions, BI is now playing a significant role in strategic decision making. It helps companies make better decisions, streamline work-flows, and provide better customer services.

Business intelligence (BI) is a collection of decision support technologies and knowledge for the enterprise aimed at enabling knowledge workers such as executives, managers, and analysts to make better and faster decisions. The past two decades have seen explosive growth, both in the number of products and services offered and in the adoption of these technologies by industry. This growth has been fueled by the declining cost of acquiring and storing very large amounts of data arising from sources such as customer transactions in banking, retail as well as in e-businesses, RFID tags for inventory tracking, email, and query logs for Web sites, blogs, and product reviews. Enterprises today collect data at a finer granularity, which is therefore of much larger volume.

### 4.1 BUSINESS INTELLIGENCE DEFINITION

Adelman et al. (2002) describe BI as a term that encompasses a broad range of analytical software and solutions for gathering, consolidating, analyzing and providing access to information in a way that is supposed to let an enterprise's users make better business decisions. Malhotra (2000) points out BI benefits that facilitate the connections in the new-form organization, bringing real-time information to centralized repositories and support analytics that can be exploited at every horizontal and vertical level within and outside the firm. Golfareelli et al. (2004) brief on BI which includes effective data warehouse and also a reactive component capable of monitoring the time-critical operational processes to allow tactical and operational decision-makers to tune their actions according to the company strategy. Gangadharan and Swamy (2004) define BI as the result of in-depth analysis of detailed business data, including database and application technologies, as well as analysis practices. Gangadharan and Swamy (2004) widen the definition of BI as technically much broader tools that includes potentially encompassing knowledge management, ERP, decision support systems and data mining.

### 4.2 THE IMPORTANCE OF BI

Businesses are leveraging their data asset aggressively by deploying and experimenting with more sophisticated data analysis techniques to drive business decisions and deliver new functionality such as personalized offers and services to customers. Today, it is difficult to find a successful enterprise that has not leveraged BI technology for its business. For example, BI technology is used in manufacturing for order shipment and customer support, in retail for user profiling to target grocery coupons during checkout, in financial services for claims analysis and fraud detection, in

transportation for fleet management, in telecommunications for identifying reasons for customer churn, in utilities for power usage analysis, and health care for outcomes analysis.

Industry studies have highlighted this significant development. For example, based on a survey of

Over 4,000 information technology (IT) professionals from 93 countries and 25 industries, the *IBM Tech Trends Report* (2011) identified business analytics as one of the four major technology trends in the 2010s. In a survey of the state of business analytics by Bloomberg Businessweek (2011), 97 percent of companies with revenues exceeding \$100 million were found to use some form of business analytics. A report by the McKinsey Global Institute (Manyika et al. 2011) predicted that by 2018, the United States alone will face a shortage of 140,000 to 190,000 people with deep analytical skills, as well as a shortfall of 1.5 million data-savvy managers with the know-how to analyze big data to make effective decisions.

## 5 BUSINESS INTELLIGENCE COMPONENTS

BI includes several software for extraction, transformation and loading (ETL), data warehousing, database query and reporting (Berson et al., 2002; Hall, 1999) multidimensional/online analytical processing (OLAP) data analysis, data mining and visualization.

Experts view BI in different ways. Data warehousing experts view BI as supplementary systems and is very new to them. These experts treat BI as technology platform for decision support application. To data mining experts BI is set of advanced decision support systems with data mining techniques and applications of algorithms. To statisticians BI is viewed as a forecasting and multidimensional analysis tool.

BI tools are widely accepted as a new middleware between transactional applications and decision support applications, thereby decoupling systems tailored to an efficient handling of business transactions from systems tailored to an efficient support of business decisions. The capabilities of BI include decision support, OLAP, statistical analysis, forecasting, and data mining.

The following are the major components that constitute BI.

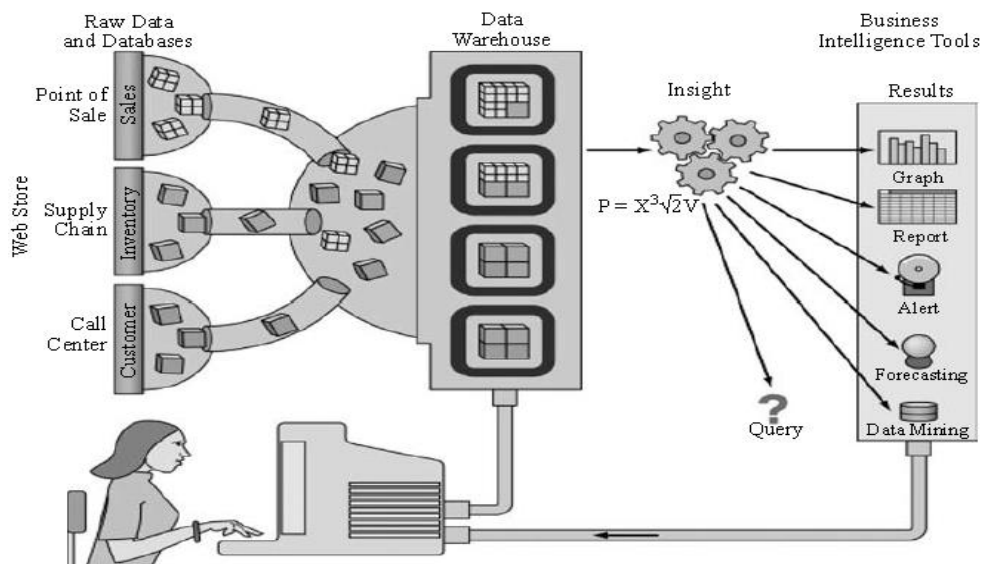

**Figure 1.**  
A basic understanding  
of BI

### 5.1 DATA WAREHOUSE

The data warehouse is the significant component of BI. It is subject oriented, integrated. The data warehouse supports the physical propagation of data by handling the numerous enterprise records for integration, cleansing, aggregation and query tasks. It can also contain the operational data which can be defined as an updateable set of integrated data used for enterprise wide tactical decision-making of a particular subject area. It contains live data, not snapshots, and retains minimal history.

### 5.2 DATA SOURCES

Data sources can be operational databases, historical data, external data for example, from market research companies or from the internet), or information from the already existing data warehouse

environment. The data sources can be relational databases or any other data structure that supports the line of business applications. They also can reside on many different platforms and can contain structured information, such as tables or spreadsheets, or unstructured information, such as plaintext files or pictures and other multimedia information.

### 5.3 DATA MART

A data mart as described by Inmon (1999) is a collection of subject areas organized for decision support based on the needs of a given department. Finance has their data mart, marketing has theirs, and sales have theirs and so on. And the data mart for marketing only faintly resembles anyone else's data mart. Perhaps, most importantly (Inmon, 1999) the individual departments own the hardware, software, data and programs that constitute the data mart. Each department has its own interpretation of what a data mart should look like and each department's data mart is peculiar to and specific to its own needs. Similar to data warehouses, data marts

Contain operational data that helps business experts to strategize based on analyses of past trends and experiences. The key difference is that the creation of a data mart is predicated on a specific, predefined need for a certain grouping and configuration of select data. There can be multiple data marts inside an enterprise. A data mart can support a particular business function, business process or business unit.

### 5.4 QUERY AND REPORTING TOOLS

OLAP provides multidimensional, summarized views of business data and is used for reporting, analysis, modeling and planning for optimizing the business. OLAP techniques and tools can be used to work with data warehouses or data marts designed for sophisticated enterprise intelligence systems. These systems process queries required to discover trends and analyze critical factors. Reporting software generates aggregated views of data to keep the management informed about the state of their business.

Other BI tools are used to store and analyze data, such as data mining and data warehouses; decision support systems and forecasting; document warehouses and document management; knowledge management; mapping, information visualization, and dash boarding; management information systems, geographic information systems; trend analysis; software as a service.

## 6 TRADITIONAL BUSINESS INTELLIGENCE SYSTEMS

The main key to successful BI system is consolidating data from the many different enterprise operational systems into an enterprise data warehouse. Very few organizations have a full-fledged enterprise data warehouse. This is due to the vast scope of effort towards consolidating the entire enterprise data. The organizations will distinguish themselves by the capability to leverage information about their market place, customers, and operations to capitalize on the business opportunities. Moss and Atre (2003) describe BI as seamless integration of operational front-office applications with operational back-office applications. The firms can make better decisions, right decisions in particular on their customers, suppliers, employees, logistics, infrastructure and gather, store, access and analyze huge amounts of records only with BI.

Current data warehousing and BI approaches are widely accepted as a middleware layer for state-of-the-art decision support systems (Seufert and Schiefer, 2005). However, they do not provide sufficient support in dealing with the upcoming challenges, such as real-time and closed loop decision making (Seufert and Schiefer, 2005).

Any new-form organization now a days experience is the value chain-set of primary secondary activities that create value for customers. Without effective BI to target process-oriented organizations for supporting is not possible.

Companies have to redesign their business processes for effectively managing and controlling business. For enabling effective business performance and identifying opportunities for enhancing the business, collecting and reconciling all operational data related to business processes is essential. This operational data from different business processes need to be collected, integrated and prepared for analytical decision-making. This analytical decision-making is essential and required for integration of decision for any management. The components for an effective BI architecture requires a well-developed data warehouse, an effective data mart and meta data management, analytical tools like data mining and OLAP and other query reporting tools and also a robust hardware foundation that can support scalability both from the data and user perspectives. (Figure 2).

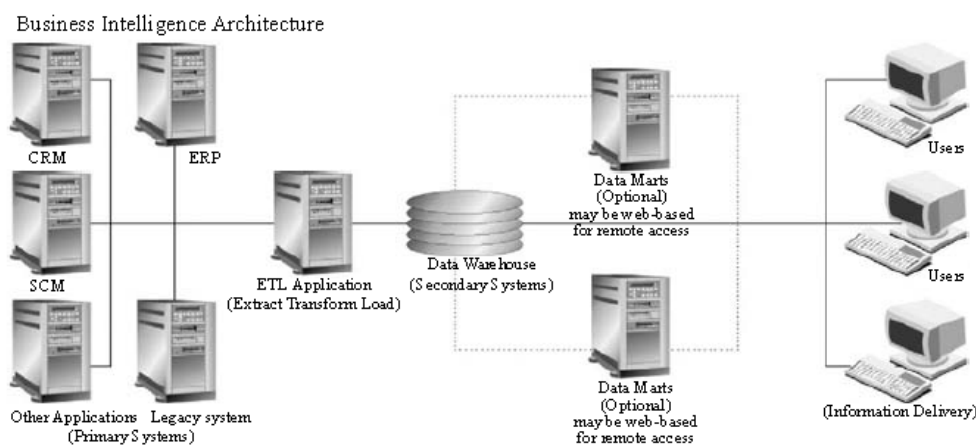

Figure 2. Traditional BI architecture

But in order to achieve competitive advantage, companies also strive towards reducing the time needed to react to relevant business operations. By organizing and deploying BI as per the organization's own characteristics, the complete value of the data stored throughout the enterprise can be unleashed.



## 7 REAL TIME BUSINESS INTELLIGENCE

---

BI systems frequently have been accused by corporates for not getting results to users in a timely manner. This may be due to data-integration problems. However, new BI approaches can process the information quickly enough to make such decisions. Concepts such as active warehousing, real-time analytics (Brobst and Ballinger, 2000; Raden, 2003) and real-time warehousing became hot topics of interest to firms. Real-time decision support provides suggestions of how to speed up the flow of information in order to achieve competitive advantage. For example, in hotel management and information systems, BI can be used to analyze customers' input and make hotel, car rental, and other offers to them when they are on the business' web site or when they visit again in the future.

Nevertheless, it is becoming essential nowadays that not only is the analysis done on real-time data, but also actions in response to analysis results can be performed in real time and instantaneously change parameters of business processes. Nguyen Manh et al. (2005) introduced an enhanced BI architecture that covers the complete process to sense, interpret, predict, automate and respond to business environments and thereby aims to decrease the reaction time needed for business decisions.

### 7.1 HOW TO MOVE TO REAL TIME BI

Real time BI system does the process of delivering information about business operations with minimum latency. This means delivering information in a range from milliseconds to a few seconds after the business event. While traditional BI presents historical information to users for analysis, real time BI compares current Business events with historical patterns to detect problems or opportunities automatically. This automated analysis capability enables corrective actions to be initiated and or business rules to be adjusted to optimize business processes.

The primary goal of real time BI is to meld analytics with management functions so that analytics become an integral part of how managers and employee teams perform their job (Figure 3). Information is collected from several operation systems for data integration. Note the different applications of BI emerging from query analysis to score card management. Hence, successful implementation of real time BI needs to focus first

On specific business needs (i.e. SCM, customer churn detection and reduction, etc.).

New service-oriented-architecture tools provide interfaces to various data types, which helps integrate data sources so that multiple applications can read them. BI's real-time capabilities can make it easier for companies to work directly with customers. A customer might be on the phone or an e-commerce web site for only a few minutes, which limits the time and amount of information a company has to make sales-related decisions.

All real time BI systems have some latency, but the goal is to minimize the time from the business event happening to a corrective action or notification being initiated.



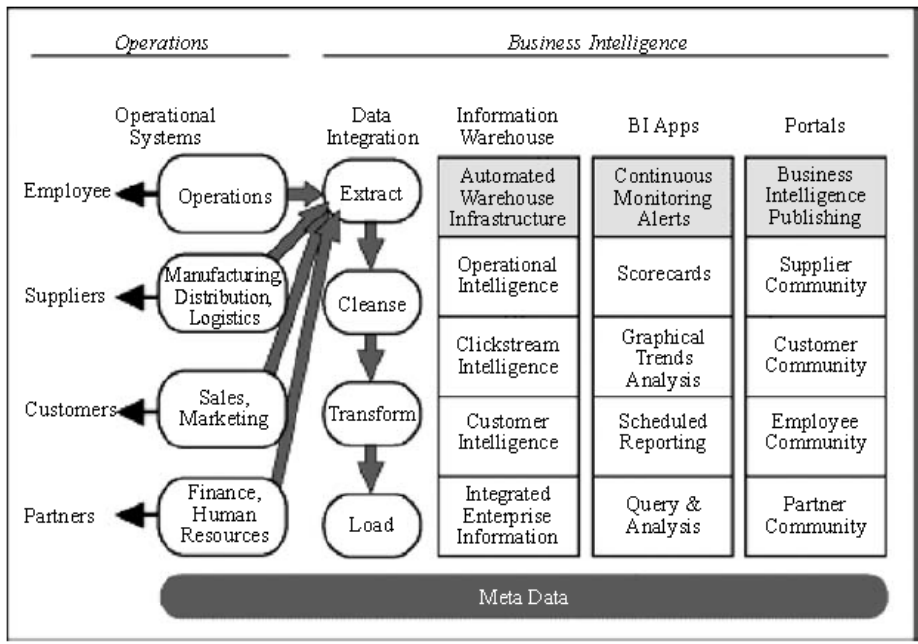

Source: Robinson (2002)

Figure 3. BI infrastructure

Nguyen Manh et al. (2005) proposed an approach to real time BI based on service-oriented architecture (Figure 4).

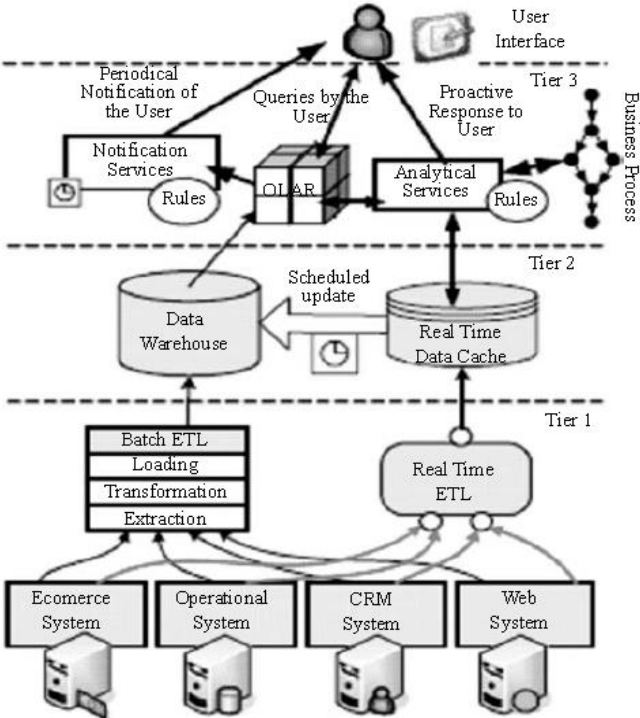

Figure 4. Real time BI architecture

Source: Nguyen Manh et al. (2005)

The concept of service-oriented architecture has been the buzz in the business technology area. These service-oriented architecture tools provide various interfaces to various heterogeneous types

of data in any organization and integrate various data sources so that multiple applications can have access to these data. Several service-oriented architecture adapters and interfaces have been developed for integrating and accessing various heterogeneous data sources.

## 8 BI AND DESCRIPTIVE, PREDICTIVE AND PRESCRIPTIVE ANALYTICS

Business intelligence and analytics (BI&A) has emerged as an important area of study for both practitioners and researchers, reflecting the magnitude and impact of data-related problems to be solved in contemporary business organizations.

We can study BI analytics from three perspectives; Descriptive analytics, Predictive analytics and Prescriptive analytics. Business intelligence is the world of descriptive analytics: retrospective analysis that provides a rearview mirror view on the business—reporting on what happened and what is currently happening. Predictive analytics is forward-looking analysis: providing future-looking insights on the business—predicting what is likely to happen (usually associated with a probability) and why it’s likely to happen.

This following figure is a pretty common way to view the worlds of business intelligence and predictive analytics.

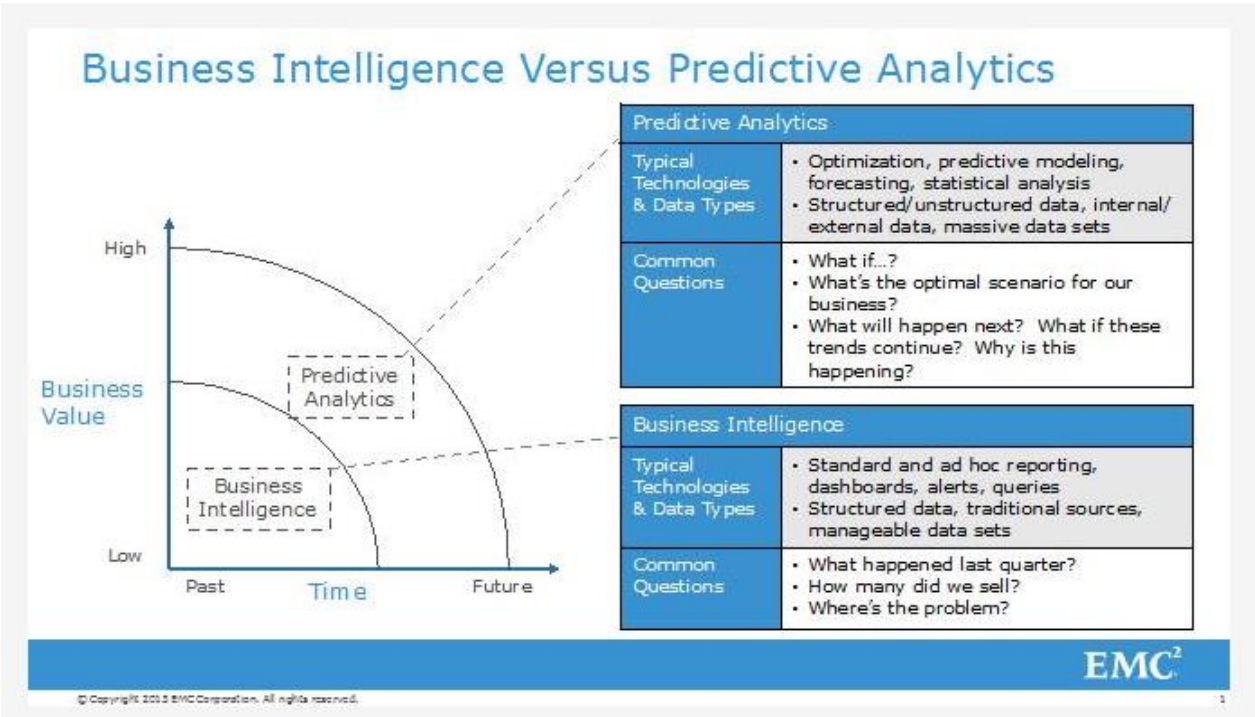

Business intelligence looks for trends at the macro or aggregated levels of the business, and then drills up, down, or across the data to identify areas of under- and over-performance. Areas may include: geography, time, products, customers, stores, partners, campaigns, or other business dimensions.

Business Intelligence is about descriptive analytics (or looking at what happened), slicing-and-dicing across dimensional models with massive dissemination to all business users.

Predictive analytics, on the other hand, builds analytic models at the lowest levels of the business—at the individual customer, product, campaign, store, and device levels—and looks for predictable behaviors, propensities, and business rules (as can be expressed by an analytic or mathematical formula) that can be used to predict the likelihood of certain behaviors and actions[2].

Predictive analytics is about finding and quantifying hidden patterns in the data using complex mathematical models that can be used to predict future outcomes.

Business Intelligence		Predictive Analytics
Who are my most valuable customers?	→	Who will be my most valuable customers? Who has the potential to become my most valuable customer?
What are my most important products?	→	What will be my most important products? What products have the potential to become my most valuable products?
What are my most successful campaigns?	→	What campaigns will be the most successful? What campaigns have the potential to become my most successful campaigns?

Finally in last phase of BI, Prescriptive analytics is related to both descriptive and predictive analytics. Prescriptive analytics is the area of business analytics (BA) dedicated to finding the best course of action for a given situation. BRMS could be a helpful method for Prescriptive analytics in terms of simplification and optimization of decision making process by extracting business rules from core application code and automating the business decisions.

## 9 BUSINESS RULES MANAGEMENT SYSTEM (BRMS)

---

In today's business environment, it is a certainty that will manage to survive especially those organizations which are striving to adapt quickly and with low costs to the new demands of market competition. Knowledge represented by internal business rules of an organization can help crystallize their orientation in order to ensure a competitive advantage in the market.

As interest for explicit manipulation of business rules grows, researches in this area seem to focus on a common goal: to identify ways that provide support for automatic propagation of changes from business environment to information systems, and further, to software applications. Thus, it aims to fill the gap between the business level and the information system level, because aligning information system with business functional requirements is a fundamental problem of all organizations. In the same time, it is essential to trace the business rules in all stages of the software life cycle.

### 9.1 DECISIONS FIRST MODELER

Decision Management simplifies business rules management systems (BRMS) implementation making it easier to:

Get the requirements right.

Know where to draw the automation boundaries.

Re-use, evolve and manage rules beyond the first business rules project.

Consolidate business rules across multiple implementations and platforms.

Decision Management improves business rules design and implementation through the process of decision discovery and **decision modeling**. Decision management is also a framework for using big data analytics to improve your rules.

Decision modeling has five steps that are performed iteratively:

1. Identify Decisions. Identify the decisions that are the focus of the business rules project.
2. Describe Decisions. Describe the decisions and document how improving these decisions will impact the business objectives and metrics of the business.
3. Specify Decision Requirements. Move beyond simple descriptions of decisions to specify detailed decision requirements. Specify the information and knowledge required to make the decisions and combine into a Decision Requirements Diagram.
4. Complete the Model. Refine the requirements for these decisions using the precise yet easy to understand graphical notation of Decision Requirements Diagrams until the decisions are completely specified and everyone has a clear sense of how the decisions will be made.
5. Generate a business rules Requirements Document. Package this information as a business rules Requirements Document if necessary.

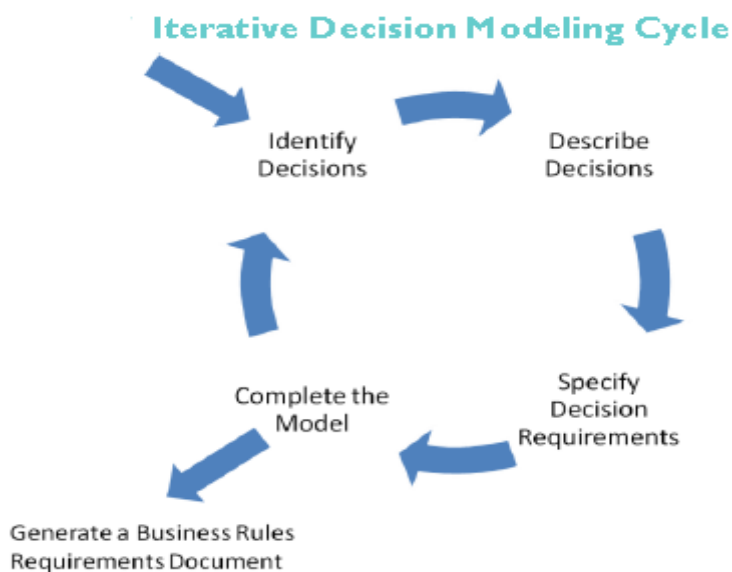

## 9.2 HOW EFFECTIVE BRMS AND DECISION MODELER COULD BE IN OUR ORGANIZATION

Making decisions explicit and managing them in concert with processes ensures an effective separation of concerns and a more streamlined design. Specifically, combining process management and decisioning will decrease process complexity and increase straight through processing while making measurement and continuous optimization easier. Decisioning also increases an organization's capacity for change and the degree of business user engagement in managing processes.

Part of being business process-oriented is understanding your —as-is processes to see how your business is truly operating. This understanding improves visibility and allows optimization of the process—the creation of an effective —to-be process. Most, if not all, business processes require decisions to be made: claims must be approved or rejected, cross-sell offers must be selected, and product discounts must be calculated. Explicitly modeling the decisions that happen in your business process ensures that the as-is model is closer to reality.

Especially when a process must handle multiple scenarios, modeling the decision-making in a process with branches and steps only can become very complex. Replacing a nest of branches and steps with a single, explicit decision point clarifies the behavior of the process, makes it easier to see if the process or the decision must change, and allows for changes in the decision-making approach to be independent from process change. Rather than handling all of the different subtypes of a particular transaction with branches and exception handling, the first step in a process can identify the particular scenario and essentially —assemble the right process from standard components resulting in a much simpler, yet more flexible process design.

Explicit decision handling also increases the rate of straight through processing (STP) and reduces the number of process instances that wait while items are put on work lists or in queues. This marriage of explicit decisions and process management keeps transactions moving with only exceptions ending up on work lists or in an inbox. With human experts expensive and hard to scale, capturing the know-how of experts in explicit decision logic and making it available everywhere focuses scarce

expert resources on exceptions and high-value cases and customers. Staff can then focus on value-add activities that require their expertise, adding further value. The number of exceptions can also be systematically reduced by developing new rules as process execution is observed—observing process performance, identifying new rules to handle particular cases, and automating those rules results in continuous improvement and process optimization.

**Illustration of externalizing a decision to simplify a process (after Vanthienen and Goedertier)**

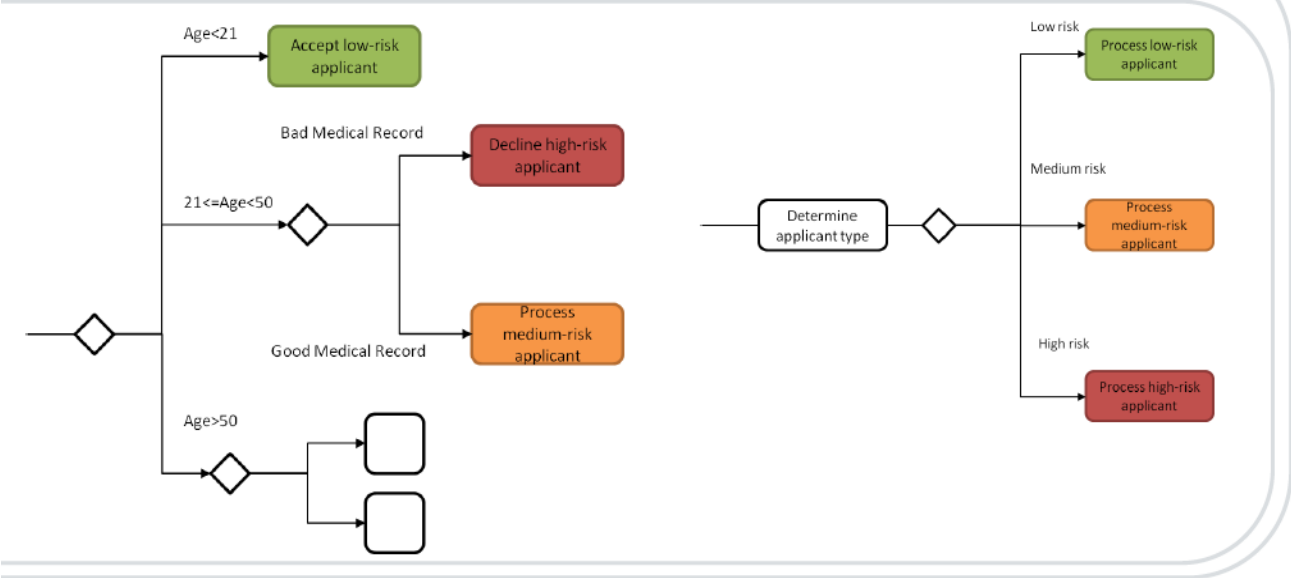

**9.3 MORE FLEXIBLE BUSINESS APPLICATIONS**

Business applications are rich sources of functionality for new and extended processes. Modern business applications become service-enabled, exposing critical functionality as reusable services, and a business process-oriented approach focuses on rapidly automating or improving a process by integrating this functionality. While including these services within an explicit and easy to change process will increase agility and flexibility, this can be undermined if the exposed functionality cannot also be easily changed. When bringing application functionality into processes, it is essential that the behavior of these functions is accessible to business users so they can change it, and so that it can be shared between multiple processes and applications. It does no good if the functions are opaque—if only the IT department can understand or change them.

For example, a core business application for order processing must be able to price products accurately. For an organization with lots of options or configurations, pricing can be very complex. If the pricing component is coded or even managed using database tables, the degree of flexibility and the ability of the business users to define new pricing models, or new configuration options that require different pricing, will be limited. Furthermore, if this component is embedded in a new process such as one designed to help customers price out and consider various options as part of a move to self-service, say, then the flexibility and agility of this new process will be compromised. It won't matter how easy it is to change the lists of products that a customer sees or how easy it is to change the process, the pricing model will act as a drag or limiting factor – no change can be made faster than the pricing model can be recoded.

Externalizing these decision-making components cannot compromise the business application itself, however. The business applications must be able to integrate them tightly, ensuring maximum

throughput and performance in production. If a decision is exposed for integration into a new process, it must perform well in that environment also. Now when new pricing is required it, can be quickly added, ensuring that both the core application and the extended process are as easy to change as they need to be.

#### **9.4 DECISION MODELING FOR PREDICTIVE ANALYTICS PROJECTS**

Established analytic approaches such as CRISP-DM stress the importance of understanding the project objectives and requirements from a business perspective, but to date there are no formal approaches to capturing this understanding in a repeatable, understandable format. Decision Modeling closes this gap. It captures the business understanding in a repeatable, understandable format. With decision modeling you will:

- Have a more complete business understanding earlier.
- Know where and how the results will be deployed.
- Reduce reliance on constrained specialist resources.

#### **9.5 DECISION MODELING FOR BUSINESS INTELLIGENCE PROJECTS**

BI dashboards and reports are known as Decision Support because they support business decisions made by business users. However, the requirements and design of these systems rarely consider decisions explicitly. Decision modeling:

- Creates an uncluttered dashboard design.
- Provides all business users and functional teams with a collaboration platform that is invaluable for discovering gaps and building consensus.
- Ensures consistent decisions aligned with strategic metrics for governance, risk-management and compliance.

Decisions First Modeler works with any business rules or analytic implementation environment, allowing you to more accurately specify your decision requirements, and then link them to your implementation for improved traceability.

## 10 A CASE STUDY BY APPLYING MIX BUSINESS PROCESS AND DECISION MODELING IN A LOGISTIC COMPANY

---

Here we would like to put the inbound processes of the logistics company into challenge and then apply the above concepts. Finally our result will be evaluated to convey the value of Decision modeling in the organization.

Basically we categorize our business processes and decisions into two levels; higher level processes and Lower level processes.

### **HIGHER LEVEL BUSINESS PROCESSES AND DECISIONS**

#### 10.1 INBOUND PROCESS

**Inbound process:** Inbound process starts by receiving a purchase order (PO) from side of the customer (or EDI), it is possible to receive a purchase order in multiple receipts. In the next step, the inbound process need to be planned and prepared for the delivery to DHL. Inbound Planning can be based on the information from the customer or maintained within DHL. If the customer knows upfront which shipments will arrive in a particular trailer, it will be possible to provide this information within the EDI message. Otherwise only ASN (Advanced Shipping Notice) or PO information needs to be provided. Assignment to trailers can be done by DHL within WM/D. It is also possible to create appointments including a dock schedule for each trailer.

Then the process should proceed to coordinate the Truck arrival, Covering Validation up until Dock assignment.

In the next phase, we should start the process of receiving inbound goods. This phase includes different tasks ranging Validating of bonded Receipt, Unloading trailers and identification of delivered Products. After a trailer is unloaded, the truck can leave the facility. It is possible to change the status of the trailer to '*left*' (*Departured*). The related time stamps are captured and made available for reports. And concurrently the storage of inbound goods can be done.

In the final step, the receipt will be closed by DHL. Normally a worker will check whether all goods of a particular receipt have arrived at their final storage location (and also any hold or other constraints on the shipment are lifted). This is done in order to print a Receipt Confirmation report and/or trigger the EDI to the customer. Closing the trailer will indicate that all goods have arrived at their final storage location. In other words, when all the goods are received the trailer must be closed and after closing the trailer no goods can be identified against the Master receipt.

The receipt confirmation will be sent to customer for their internal process.

Bellow there is a business process model of Inbound logistic which was provided by DHL.



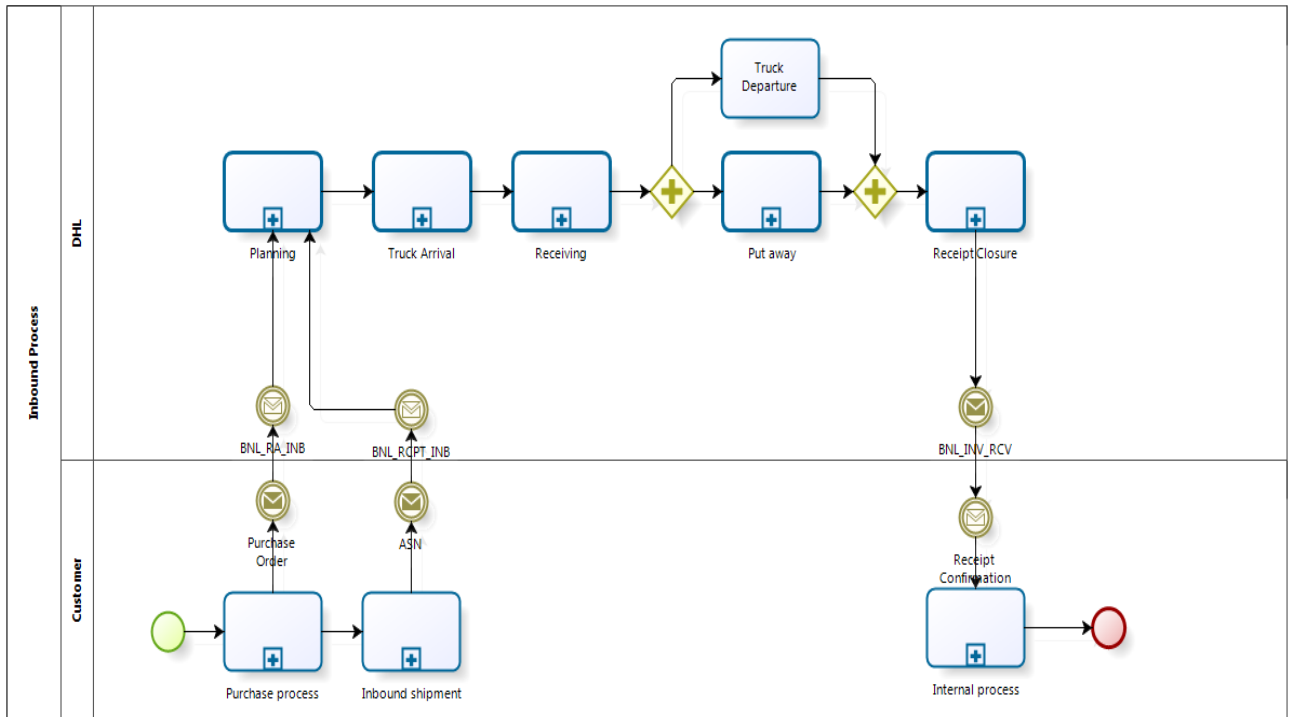

There are some clear faults in this process. Therefore we decided to improve it. While we are modeling the business process of DHL, we should dedicate a **specific pool** to its internal processes. For instance, in above business process the pool of inbound process of DHL should be separated from customer (which needs its own pool with the name of customer). Because the business process of our customer is within their own organization (not in DHL). Next, we can see faults in the start point and the end point of our process. We should keep in mind that we are modeling DHL business process so definitely whole the process from the first point to the end point should be placed in the pool of Inbound Process. However, we see those in the customer side. BPM is the foundation of Decision Modeling so it is important to put effort into making those processes as accurate and complete as possible.

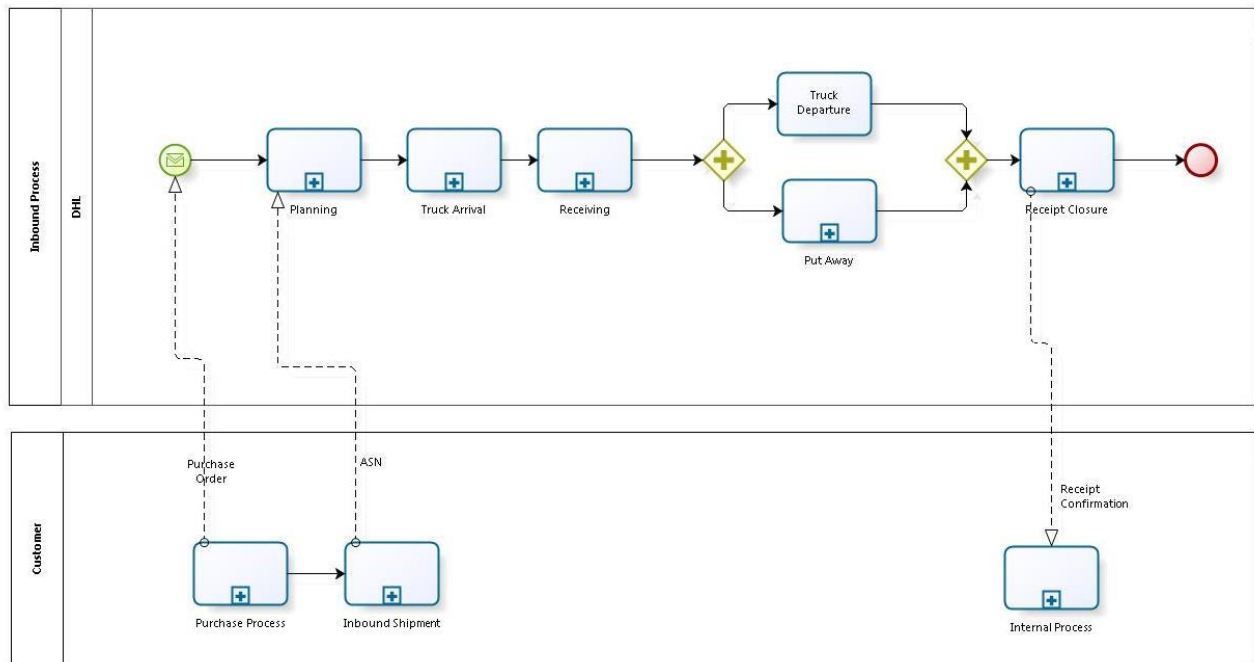

Powered by  
bizagi  
Modeler

Next, decisions should be extracted from those processes.

Basically we should seek out where there are work lists, escalation and critical gateways. At those spots we can conclude the decisions. But we should note that not all the gateways in business process acts as a decision point (Exclusive gateways are often our main decision points). For example in above process, the parallel gateway leads to the execution of two processes concurrently. Thus it doesn't mean any decision is required to take.

Also by looking at the above business process, we can find out that extracting those decisions from **high level process** is not straight forward. So for accessing those decisions we need to take one step further and study our **lower level process** which is linked to the high level process in the form of sub-process.

Based on this logic, we are going to analyze some of those main sub processes; planning, truck arrival and receiving. Then we can extract their decisions.

### **LOWER LEVEL BUSINESS PROCESSES AND DECISIONS**

## **10.2 INBOUND PLANNING**

For discovering the hidden decisions of inbound planning we should first model the business process.

**Inbound Planning:** Inbound Planning is received from the customer or maintained internally. Based on this, Inbound Shipments are planned in WM/D.

Truck arrival information is available with the following data:

- Expected and actual arrival
- Trailer status and timestamps

- Expected vs actual received quantity
- Number of Items with instructions
- Customs information and status

After checking EDI information, the truck level information should be checked. In a case that there was no truck level information we should create a Purchase Order. If the truck level information is provided no action is needed. Then based on truck level information a Master Receipt should be created.

In the next step, dock status should be evaluated and if it is a not planned, dock planning will be required. The system provides the possibility to register all assignments against a dock. This has to be done manually. The Master Receipt contains an expected date and Master Receipt should be assigned the Appointment.

It's useful to consider that from the first until the last point of Inbound planning, Monitoring has been performed concurrently. Also we should note that the Creating Purchase Order is based on the received EDI and by the integrator.

The planning is mainly based on the "Creating a Master Receipt" process. A Master Receipt may consist of multiple purchase orders and it should have a one to one relation to a receiving trailer. Also based on the received EDI the integrator creates a Master Receipt.

Bellow we can see the BPM for Inbound Planning made available by DHL:

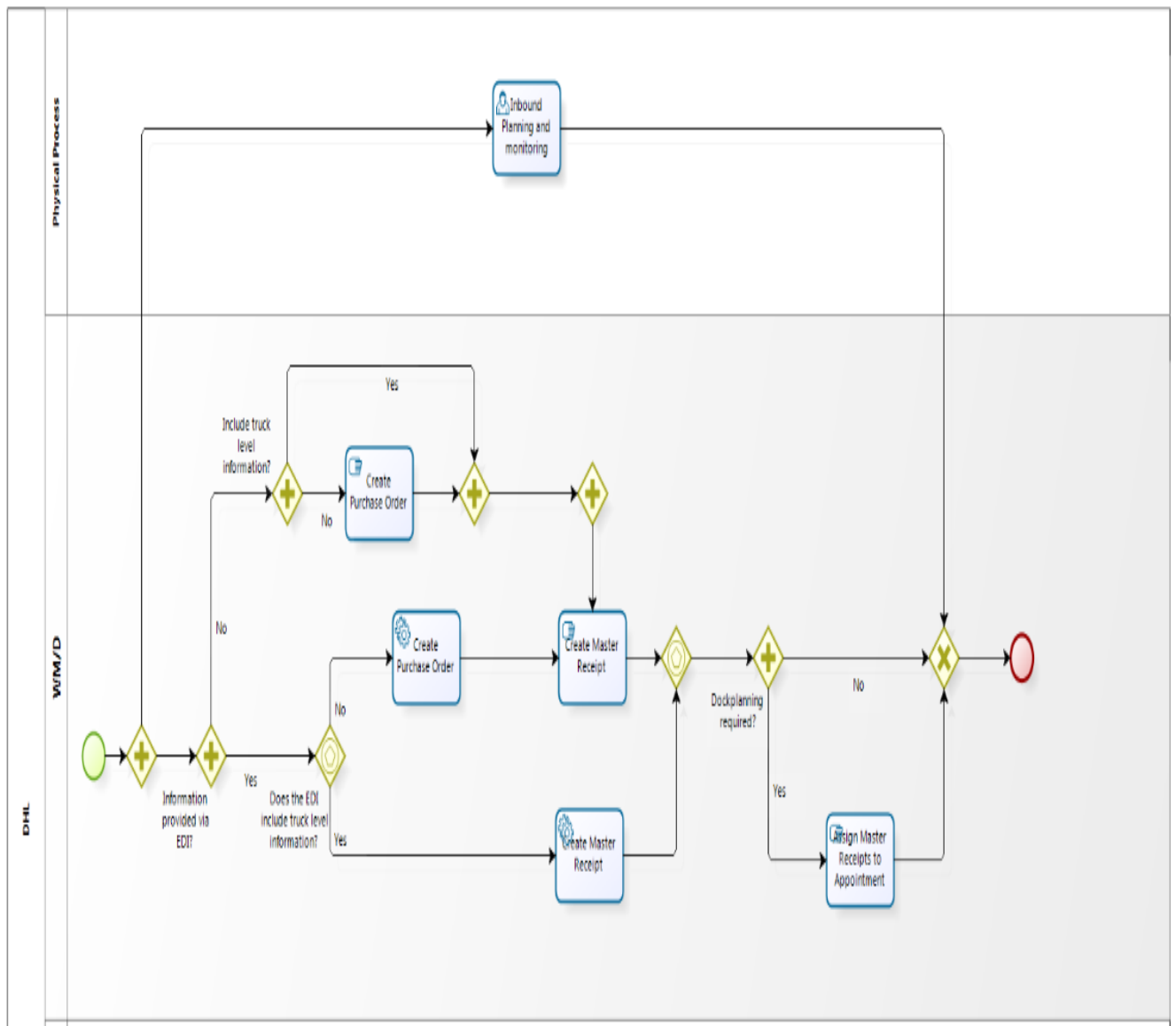

Now those processes need to be improved as bellow.

As you can see, there are a lot of gateways in our business process. That makes our models too complicated. We are going to optimize our process by eliminating unnecessary gateways and replacing them by tasks. For example, there are gateways to check if 'Information was provided via EDI' and if 'truck level information was included'. If they were not provided, we would create purchase order. But we should note that by using decision modeling we can shift these decisions and gateways to DMN. Then we replace those gateways with the tasks of 'check EDI' & 'check truck level information' and finally one gateway to assess truck level information. Then we shift the relevant decisions to DMN.

Therefore later we will see in decision modeling, by checking EDI information and truck level information we will decide whether to create a purchase order or not. Also here we can see the wrong selection of gateways. Throughout whole the process we need exclusive gateways because only one of the paths can be utilized.

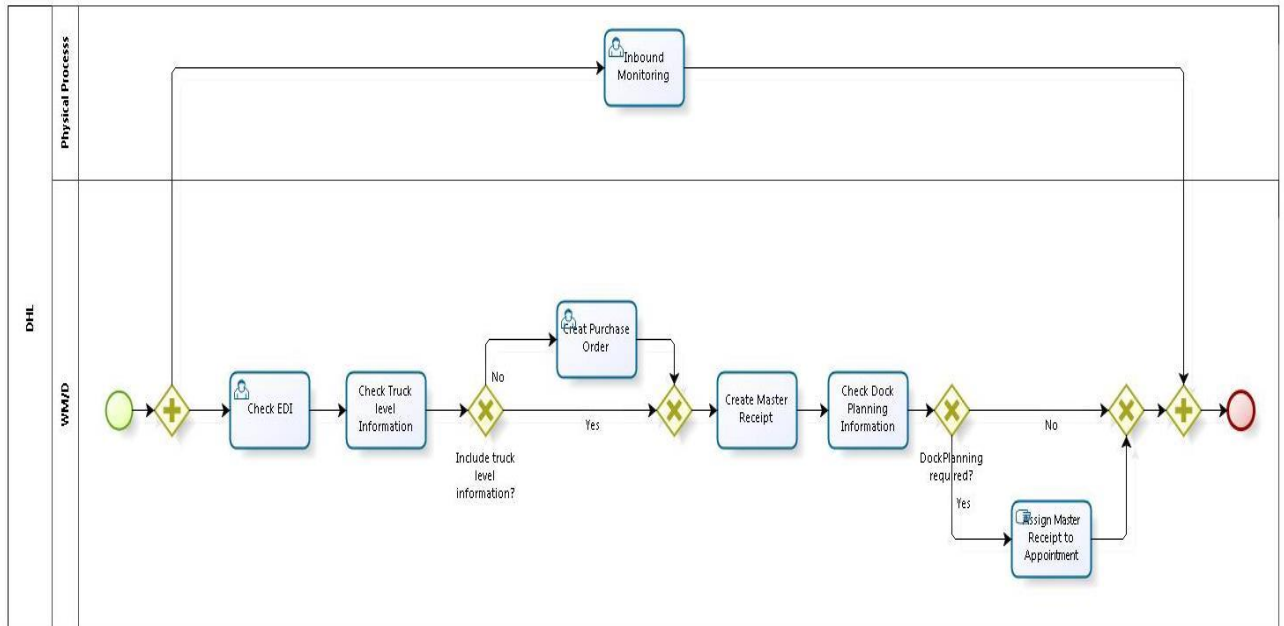

Taking the above process into account, now we can find the required decisions for inbound planning.

**Inbound Planning Decision:** Based on the received EDI information the Integrator decides to create a Purchase Order. A Purchase Order is based on Truck level information (e.g. trailer or container, expected date of arrival).

In next step we should decide if Receipt Order should be created based on the received EDI.

Furthermore a decision should be taken in terms of “Dock Planning” based on the dock information provided. The system provides the possibility to register all appointments against a dock. This has to be done manually.

Finally according to above decisions, we can plan inbound. Inbound planning is received from the customer or maintained internally. Based on this planning, inbound shipments are planned in WM/D. Thus for taking the final decision for inbound planning, other four decisions are required.

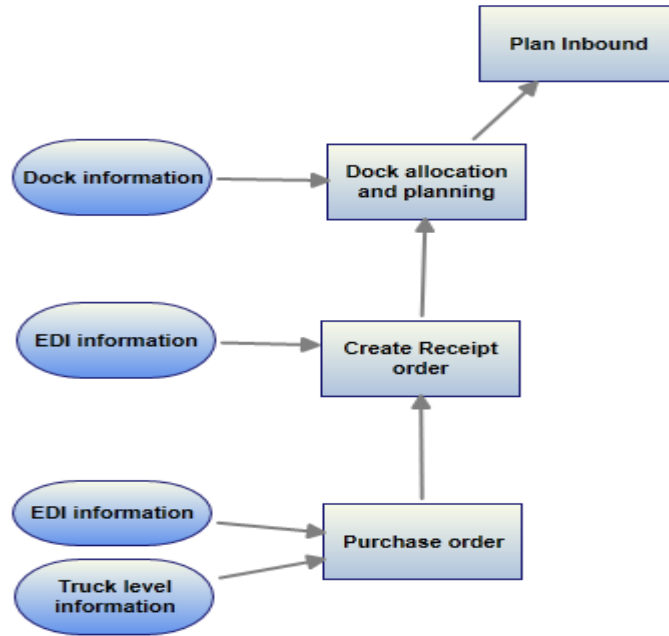

### 10.3 TRUCK ARRIVAL & DOCK ALLOCATION

**Dock allocation process:** when a truck arrives at the gate, we should validate if the truck is planned or expected. If the truck is unknown, the truck planning should be proceeded (in inbound planning). Otherwise, in the case of a known planned truck we should check if the trailer is allowed. If not, then we will reject the truck. But in the case of an allowed truck, we check the truck in and register the Truck arrival time. Following up we will assign the destination yard and dock to the truck. Concurrently from the point of Check in we are moving the trailer (physically by driver) along the rest of process.

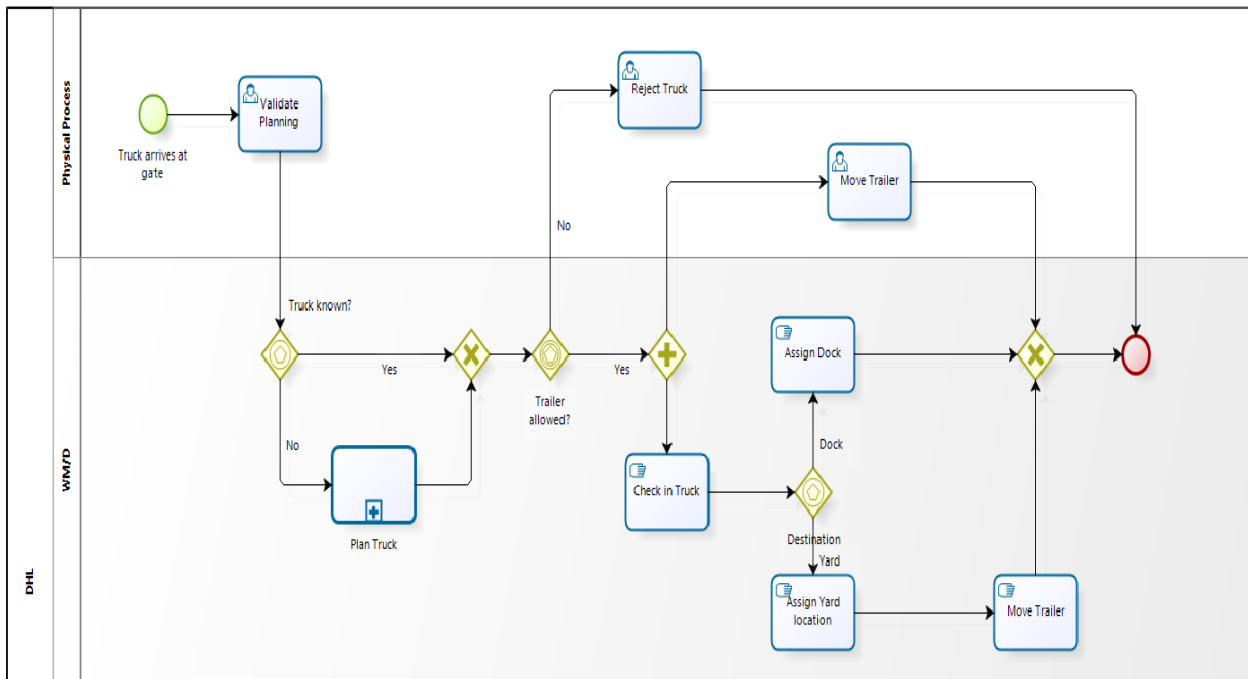

Here we are trying to improve the Business process models by eliminating the unnecessary Gate ways and symplifying the processes. Here also we need to choose a suitable type of gateways (which is exclusive gateways). We are going to optimize our process by removing the “Destination yard” gateway. we will also add the “validate the truck” task to our process.

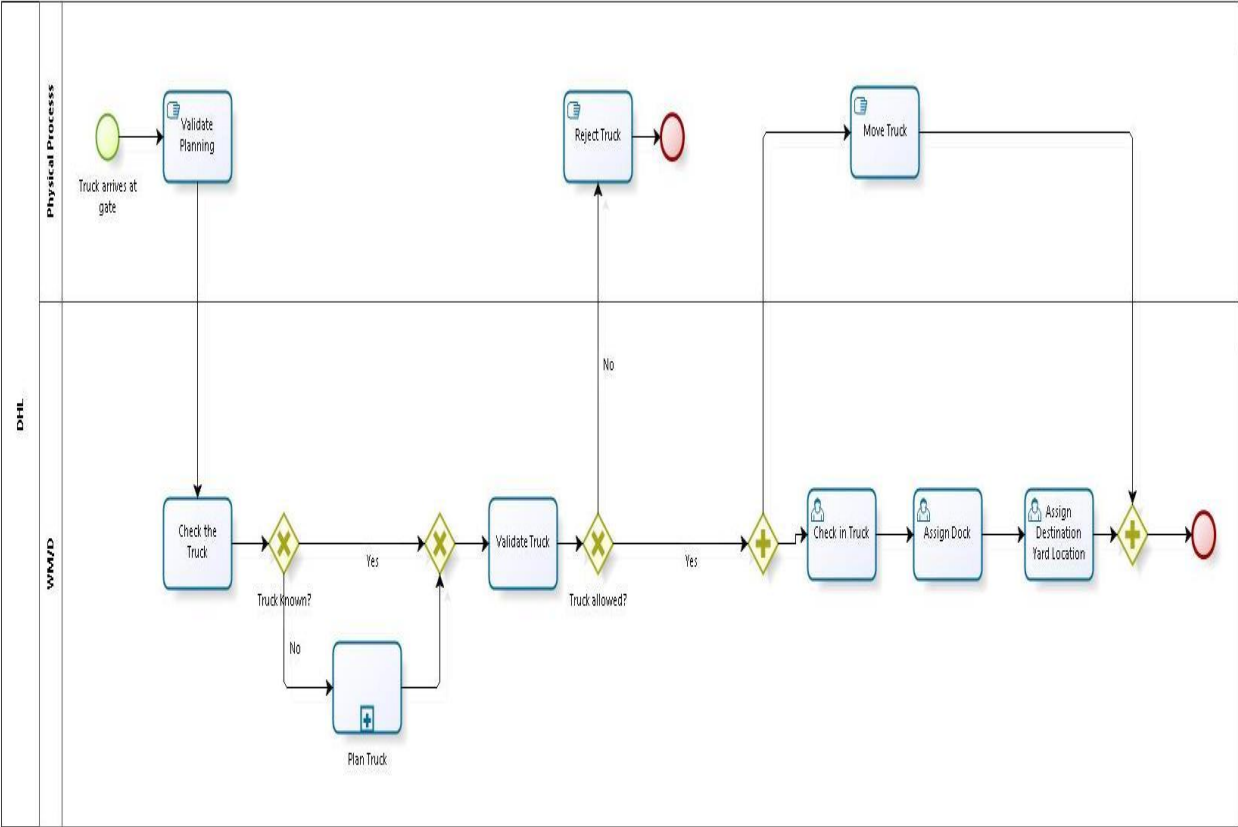

**Dock allocation Decision:** We can conclude based on the above business processes that we need to make decisions in two main points. Firstly the arrived truck should be validated by considering Inbound Planning data and truck information. In next step we should decide if we assign a specific Dock or Yard to that truck based on Truck level information and EDI information about free Dock and Yard.

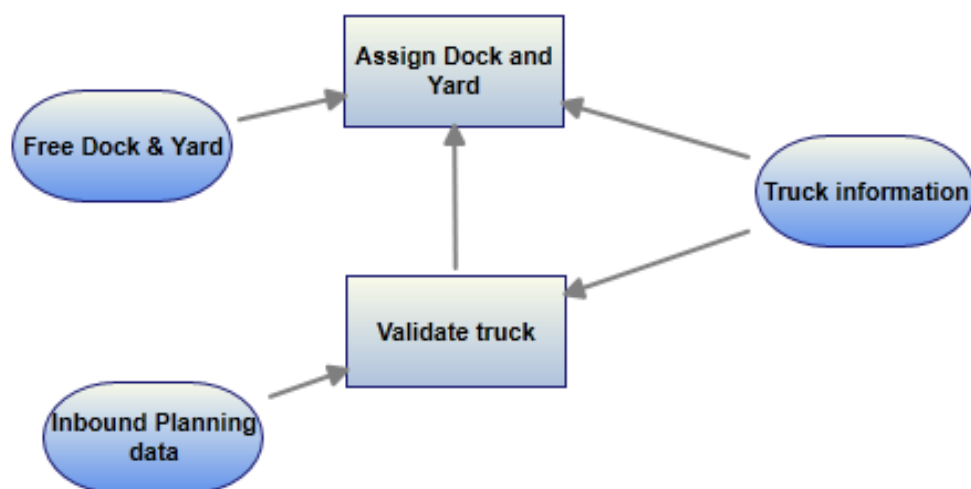

## 10.4 RECEIVING

### 10.4.1 Business Process

As an example the process of Receiving can be described by a sequence of tasks that include decisions (business rule tasks) and calculations (general automated tasks). The following figure uses the BPMN standard notation to describe this process.

**Receiving Process:** When truck has arrived at dock we check if client is a bonded client and the shipment will be validated. Then we mark the receipt as bonded. If it is not a bonded client or shipment, we will mark receipt as Free. (It can be configurable per client. E.g. a field or policy to define whether it's a bonded or nonbonded client). When status 'Free' is selected, the truck is immediately released.

In the case of a bonded client and shipment the status 'Bonded' is selected, then the interface will be sent to the customs application. In the next step, the arrival of the shipment should be confirmed based on the MRN number in DMS (in Longdon). Then the NCTS (New Computerized Transit System) proceeds. After a predefined period of time in the customs application checks will be done, then the truck will be released from transit. From here it is the responsibility of DHL that the goods will be registered in the bonded warehouse environment in Langdon (Warehouse Software). Then customs operators check the release from transit. After the validation phase, we need to print a report. To support the actual receiving process a Receipt Notification Report can be printed.

In the next step, the trailer should be unloaded. Here we unload products from trailer physically. Actual data can be registered on the Receive Truck Summary Report.

Then the Quality Check task needs to be performed. Furthermore we should register the Quality of received products. Quality issues can be registered on carrier, supplier or Receipt/Item level.



Afterwards we can prepare for Identification. Based on the information on the “Receive Truck Summery Report” the goods can be sorted and restacked if required.

Then the new items should be assessed. In case a new item is in the receipt, a ‘new item procedure’ will be used. In the next step, we need to identify the products. Product Identification includes Load Identify and Load Receive. If the load is bonded, the customs Receipt will be confirmed. Also the confirmation will be sent to Langdom. Here after proceeding custom receipt, we can release the customs Hold. Then the goods should be scanned to the receiving location. This can be a receiving staging location, a product deposit location or eventually the final storage location.

In the bellow diagram you can see the primary Business Process Modeling of Receiving process in DHL:

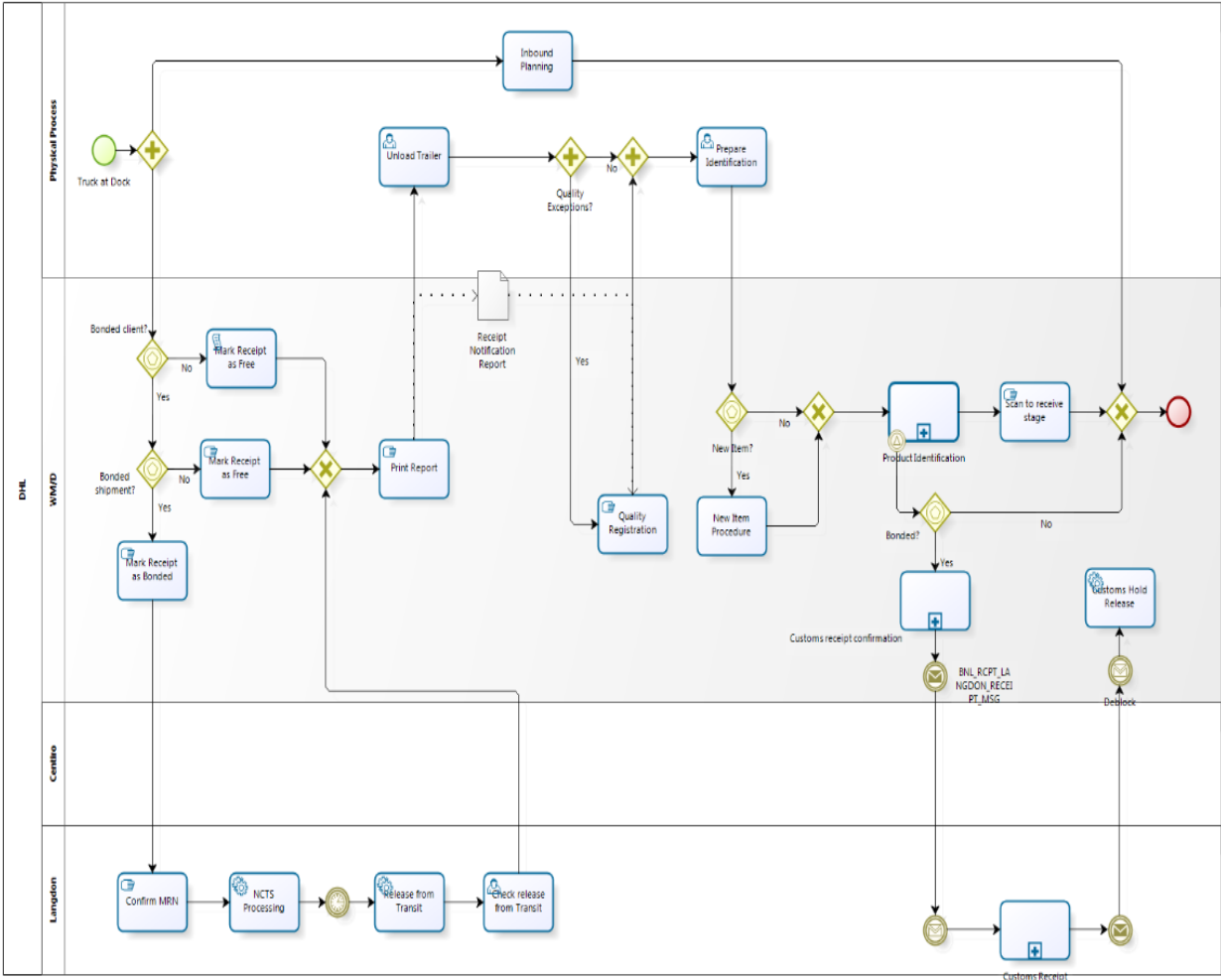

But in the following we are trying to improve those models by clarifying and adjusting our Models to the real current business processes of the organization.

At first we should try to simplify the business process as much as possible by eliminating unnecessary gateways or number of tasks. For instance, we don't need to have “Inbound planning” within our receiving process because already we did our inbound planning. Also there are two gateways which are checking the bonded client and bonded shipment, but as you can see their results are same. So we can merge those two gateways to one. Another point is to select correct gateways. For instance

to assess the bonded client and shipment we need exclusive gateways because only one of the paths can be utilized.

In addition we should note which tasks is a physical process. For example quality check is part of physical process. Also we should keep in mind that we can't leave any task without any end point or result. Here "customer hold release" left without any end point.

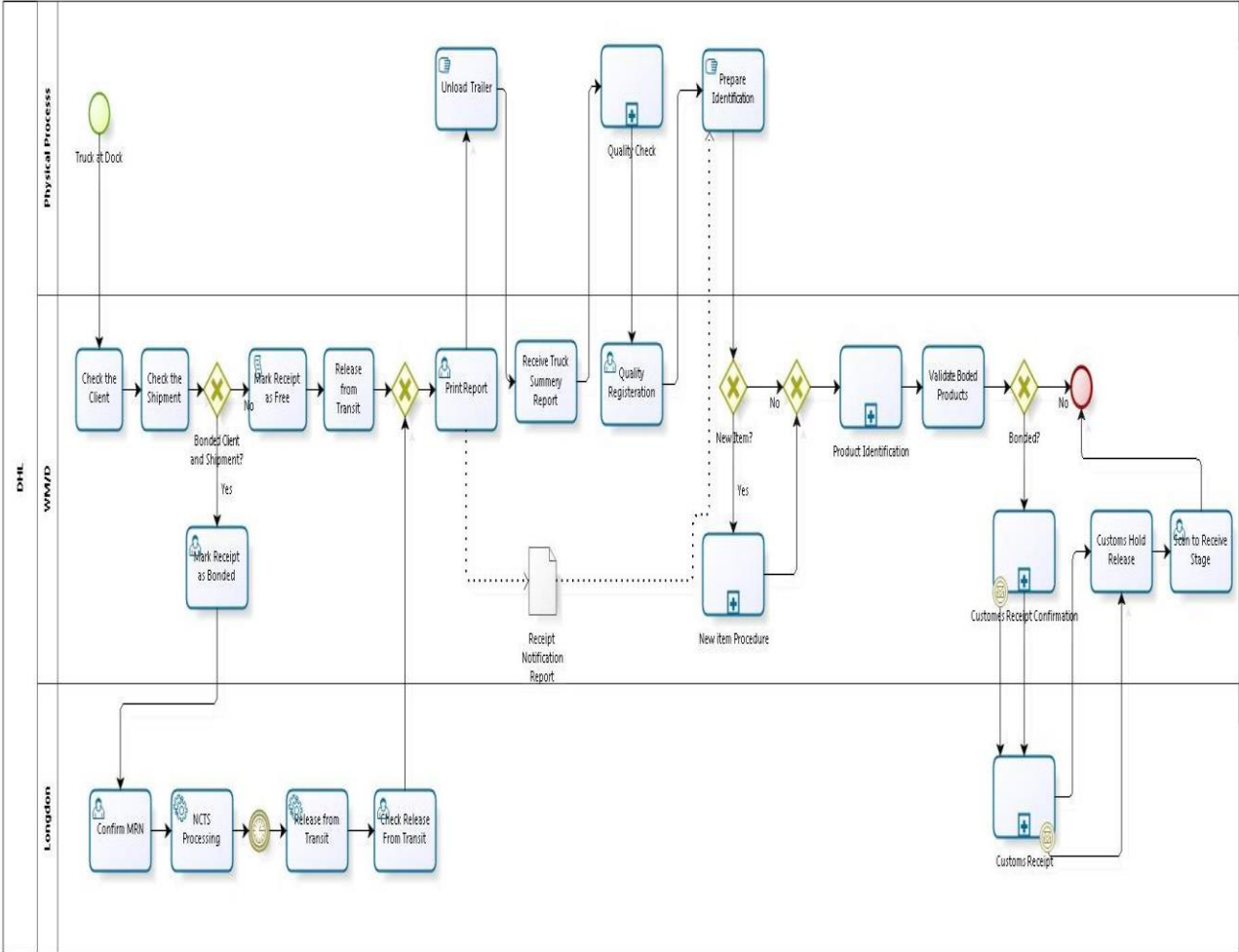

10.4.2 Decision Requirements

Now that the process context of the decision has been represented it's time to look at the decision through two additional perspectives:

- (1) The decision as an encapsulated element with its own domain, influencers and description.
- (2) As part of a larger context of how decisions are handled generally in the organization – a decision lifecycle independent of process and/or code lifecycles (or at least carrying its own nuances).

### 10.4.2.1 DMN Decision Requirements Graph

The DMN Decision Requirements Graph (DRG) models a domain of decision-making in its entirety showing the dependencies between decisions that it encompasses. The elements modeled are the key decisions, their data inputs, encapsulated business logic (termed Business Knowledge Models) and the authorities for said logic (termed Knowledge Sources). The interaction between any two elements is called a requirement (supported are Information Requirement, Knowledge Requirement, and Authority Requirement). The following figure shows the full domain for the Customs receipt Confirmation.

In this case, there is a root decision (Customer Receipt Confirmation) and it shows four decisions that it is dependent on: Identify the product, Bonded Receipt, Quality Check and Identify a New Item. A Bonded Receipt is dependent on two other decisions. Each of these two decisions has one Information Requirement (input data). Furthermore the Quality Check decision is dependent on a Bonded Receipt Decision. It also has a Business Knowledge Requirement (in this case described in the language of decision table) and also on the Information Requirement (input data).

**Receiving Decisions:** According to Receiving Business Process Models, the first decision needs to be taken is to assess the Bonded Client based on client information. Then the next decision is assessing the Bonded Shipment based on Shipment information. The first two decisions are prerequisites for deciding about whole the receipt if it is bonded.

In the next phase, the Quality should be assessed and decide about the final Quality of received goods based on products data and Business Knowledge of Quality Assessment (Decision Table).

In the next step the new items should be recognized based on the products data. Then within the GUI, a user should decide which loads and products should be identified and validate based on the knowledge of the GUI and also by considering to all three required decisions.

Finally all those four decisions are required to take final decision about customs receipt and its confirmation.

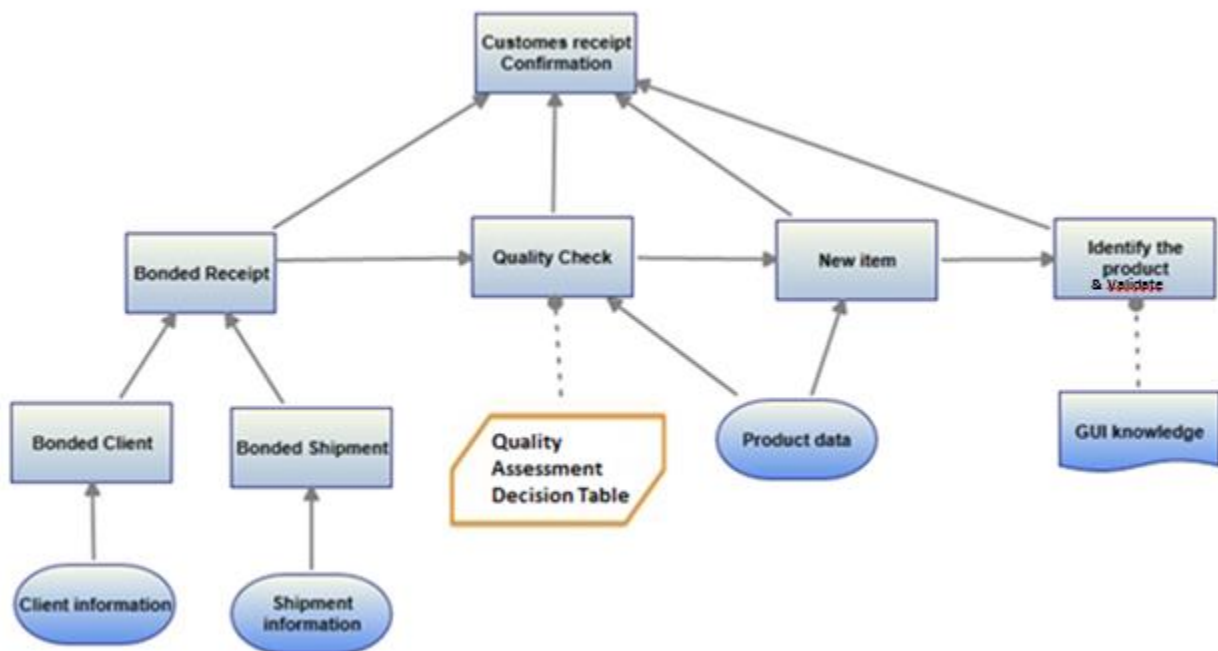

Since a DRG covers an entire domain it can quickly become unwieldy, however, in this scenario several simplifications have been used and therefore the entire DRG is easily accessible.

For any significant domain of decision-making a [Decision Requirements Diagram] DRD representing the complete DRG may be a large and complex diagram. Implementations MAY provide facilities for displaying DRDs which are partial or filtered views of the DRG, e.g., by hiding categories of elements, or hiding or collapsing areas of the network. DMN does not specify how such views should be notated, but whenever information is hidden implementations SHOULD provide a clear visual indication that this is the case.

If a graphical representation for Decision Requirements becomes unmanageable, one may switch to an equivalent tabular representation, e.g. using the tables of the type “Decision” provided by OpenRules.

**10.4.2.2 DMN Decision Requirements Diagram**

The following figure below shows the filtered notation employed in a high-level Decision Requirements Diagram (DRD) highlighting only the main decisions. Only the decision Customs Receipt Confirmation is specified fully as all its requirements are presented. It uses four other decisions as input.

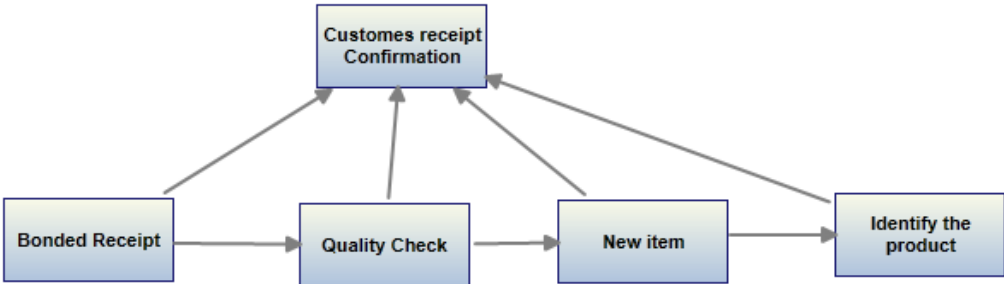

From this high-level DRD, the “Quality Check” sub-decision is selected for further detail. The following diagram is a DRD that shows a view of the DRG that filters all the decisions except for fully specifying the Quality Check decision.

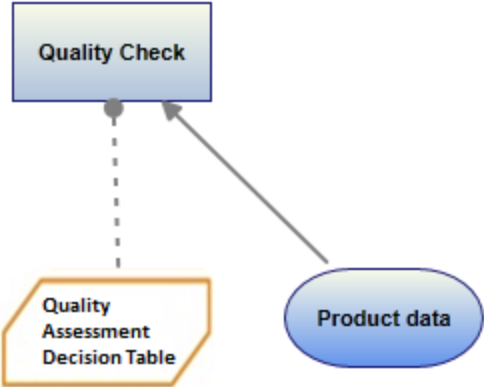

### 10.4.3 Decision Logic

Now that the processes have been mapped out and the decisions represented in their appropriate context, it is time to provide the actual decision logic in its most appropriate representation. This may be a decision tree, decision table, function, algorithm, etc.

A business knowledge model may contain any decision logic which is capable of being represented as a function. This will allow the import of many existing decision logic modeling standards (e.g. for business rules and analytic models) into DMN. An important format of business knowledge, specifically supported in DMN, is the Decision Table.

### 10.4.4 DMN Decision Tables: Quality Assessment Decision Table

The Quality Assessment Decision table feeds into the Quality Check decision and generates a subset of the different ways for inspecting the quality of received products and materials in inbound logistic. The objective of its Business Knowledge Model, represented by the decision table shown below, is to generate different processes based on existed rules of quality assessment.

Decision Tables in DMN are used to represent Business Knowledge Models tied to the decisions (sub-decisions) represented in the DRG and DRDs. For example, the Quality Check sub-decision from the DRD in the diagram uses Quality Assessment Decision Table that is represented as shown in the same diagram.

## Quality Check in Receiving Process

DHL didn't have an integrated quality check framework and available schedule. Here we will prepare one standard framework. That was designed specifically for step by step quality assessments based on one of the models of inbound quality Inspections which is well known in logistics world. Then by using this frame we create our Decision Table and link it to our decisions diagram.

Quality is important all along the supply chain. However, one area that is very important in the monitoring of quality is the inspection of items that arrive at the warehouse from your clients. Ensuring that the products and raw materials are of the correct quality or specifications based on agreed KPI and received quality.

In different ways the products or raw material will be subject to inspection:

1. Visual Inspection
2. Sampling
3. Failing Inspection

#### 10.4.4.1 Visual Inspection

Items that arrive at the receiving dock should first be visually checked for defects or obvious issues. For example, a drum of chemicals may be visually inspected and if found to be dented or leaking, the item could be rejected before it is unloaded. Items that are in packaging may also be rejected if the packaging is damaged. The quality department may have specific instructions for the warehouse depending on the item that is being received.

#### 10.4.4.2 Sampling

When an inbound delivery arrives for a large number of a particular part, the warehouse may not be required to inspect each and every item. In these cases the quality department may suggest a sample of the delivery be inspected. The sample size may be determined by the quality department and may

depend on the required level of inspection, the quantity of the items received, and meeting the necessary specifications.

**10.4.4.3 Failing Inspection**

Some products that are received at the warehouse may fail either the initial visual inspection or testing by the quality department. In whatever case, the company then has to determine how to deal with the quality issue. There are a number of scenarios that can be employed.

- **Reject the Delivery** – if the inbound delivery is not up to the quality required then the delivery can be rejected and sent back to the client.
- **Return for Replacement** – if the items do not meet the specifications, the items can be returned to the client for replacements. This is common when the items are in stock items at the client and a quick turnaround can be achieved.
- **Rework the Parts** – if the delivered items do not meet specification, but the quality department along with the client interface believe that they can work with the parts supplied, then the sub-par items can be reworked to get them up to the specification required. This is an option when it would take weeks or months to get replacements from the supplier and a delivery for a customer could be delayed.
- **Accept with Discount** – if the items do not meet specifications, but the client wants to sell them elsewhere, then the purchasing department of customer can negotiate with the supplier to accept the items with a price discount. If the vendor is unwilling, then the parts will be returned.

Here we tried to use simple language to explain more about the rules of quality check in receiving process. But to make it more standard, structured and understandable, we can use “decision tables”.

Quality Assessment Decision Table						
Requirements						Decisions
Visual Inspection	Sampling	Failing Inspection	The items are in stock items at the client	The sub-par items can be reworked	The clients want to sell them elsewhere	
√	x	x	–	–	–	Approve the Quality
√	√	x	–	–	–	Approve the Quality
√	√	√	x	x	x	Reject the Delivery
√	√	√	√	x	x	Return for Replacement
√	√	√	x	√	x	Rework the Parts
√	√	√	x	x	√	Accept with Discount

DMN standardizes some general aspects of decision table modeling concepts such as “Hit Policy” and “Aggregation”. The most popular types of Hit Policy are “Single Hit” and “Multiple Hit”. For a single hit decision table the execution stops when the first rule (column) is satisfied. For multiple hit

decision tables all satisfied rules will be executed allowing rule overrides and various kinds of aggregation. For example our quality assessment decision table should be defined as “Multiple Hit” as we want any satisfied rule to add a new action against quality check of received materials.

An invocation is a container for the parameter bindings that provide the context for the evaluation of the body of a business knowledge model. The invocation includes the name of the decision, the name of the decision table and the instructions for how to map the decision inputs into the rows of the decision table. As an example of the most basic mapping, the Failing row takes its input from the FailingInspection attribute input.

Quality Check Decision	
Quality Assessment Decision Table	
Visual Inspection	VisualCheck.VisualInspection
Sampling	SampleCheck.Sampling
Failing Inspection	Failing.FailingInspection
The items are in stock items at the client	AvailableItems.StockItems
The sub-par items can be reworked	ReusableSub-par.ReworkedSub-parItems
The clients want to sell them elsewhere	SellingItem.SellItems

In quality assessment decision table we have seen that inspection is one of the main requirements to take the final decision in terms of quality. So we can go into further step and explore the business knowledge behind Inspection procedure and plan which lead us to the final Inspection results.

**10.4.5 DMN Decision Tables: Inspection Plan Decision Table**

**10.4.5.1 Inspection Procedure:**

10.4.5.1.1 Inspection Initiation

Inspections can be triggered manually or automatically. In an integrated scenario, they can be initiated by the overlying business process, for example, when purchase orders are created, but they

can also be created manually for various events that occur throughout the entire supply chain process, such as goods movements.

To automatically create a planned inspection, a valid inspection plan must be prepared. This is master data that is maintained in the *Quality Planning* work center. As part of the inspection plan, you define key parameters and sampling procedures. You can also assign quality codes and inspection instructions in the form of notes or attachments to the inspection plan.

#### 10.4.5.1.2 Sample Drawing and Preparation

Once an inspection has been triggered, the system tries to select an appropriate inspection plan and inspection execution can begin.

The number of samples, that is, the sample size, to be taken for an inspection is determined by the inspection plan based on the sampling procedure that has been maintained.

If an inspection is unplanned and no inspection plan is used, the system determines the sample size based on the lot size.

A sample drawing instruction and, if necessary, bar-coded labels can be printed at this point to assist the quality inspector.

After the samples have been taken and distributed to the relevant areas, you can report that the inspection is ready for results recording by setting the *Inspection Prepared* status in the *Quality Control* work center.

#### 10.4.5.1.3 Inspection Execution

At this point, the quality inspector inspects the samples that have been taken from the product. To support the inspector, inspection instructions can be displayed as graphics or printed out as forms.

#### 10.4.5.1.4 Results Recording

When the samples have been inspected, that is, the inspection has been executed, you can access a personalized work list in the *Quality Control* work center where you can select the inspection for which you want to record results based on selection criteria, such as material, date, or inspection type.

You can record inspection results using:

- Notes (to describe deviations in text form)
- Documents (for example, to attach pictures showing defective parts)
- Quantitative inspection characteristics (for example, to record measured values)
- Qualitative inspection characteristics (for example, to describe defects using quality codes)
- Summarized inspection results (for example, the number of nonconforming units and/or defects)

#### 10.4.5.1.5 Quality Decision

After all inspection results have been recorded, you can complete the inspection in the *Quality Control* work center by making a decision about the quality of the inspected product. The quality decision represents a final evaluation of the inspected product from a quality perspective and determines whether the product is accepted or rejected for further use. It is also used to update the



quality level in the quality history, which can affect sampling for the next inspection of the same type.

#### 10.4.5.1.6 Follow-Up Actions

Follow-up actions can be executed manually or automatically based on the quality decision. You can, for example, print out the inspection results or ask involved parties to block stock.

### **10.4.5.2 Inspection Plans**

#### 10.4.5.2.1 Overview

Inspection plans are the basis for quality inspections. An inspection plan contains basic data for your inspections including:

- Inspection instructions
- Sampling procedures
- Key parameters
- Assigned quality codes
- Assigned quality documents
- Key Parameters

You create an inspection plan for a specific inspection type. The system provides the following inspection types:

- Receiving Inspection - Supplier Delivery
- To inspect incoming products from supplier deliveries
- Receiving Inspection - Customer Return
- To inspect products returned by customers
- Receiving Inspection - First Article
- To inspect and validate first articles received from suppliers
- Receiving Inspection - Stock Transfer
- To inspect products delivered from company subsidiaries

You can also create an inspection plan according to the following criteria:

- Product, An inspection plan specific to a particular product
- Product Category, An inspection plan specific to all products in a particular product category
- Site, An inspection plan specific to a particular site
- Supplier, or Customer, or Resource, An inspection plan specific to all goods received from a particular supplier, or all goods sent to a particular customer, or all produced parts assigned to a particular equipment or human resource.

You can create inspection plans for any combination of these criteria. For example, you could create a plan to inspect a particular product procured from a particular supplier. Where there are multiple inspection plans available for the criteria, the system selects the most specific plan that is suitable for the inspection.

#### 10.4.5.2.2 Inspection Plan Determination Sequence

Where there are multiple inspection plans available for the key parameters, the system selects the most specific plan that is suitable for the inspection. If, for example, the inspection type is Customer Return and this is the only key parameter that has been maintained, then all customer returns can be

processed with this inspection plan (inspection plan A). However, if you have a more specific inspection plan (inspection plan B) that specifies the inspection type Customer Return and the product Heater, then the system will automatically select inspection plan B whenever there is a customer return for a heater and the inspection plan A whenever there is a customer return that is not a heater. It always selects the inspection plan in which the most parameters relevant to the inspection have been maintained.

In addition, the key parameters have priorities that allow the system to select the most suitable inspection plan. The inspection types all have the same priority, but the other key parameters have different priorities:

- Product — priority 1
- Product Group — priority 2
- Site — priority 3
- Supplier, Customer, or Resource — priority 4

This means that if you have two inspection plans for receiving inspections:

- Inspection plan 1: Product = PA
- Inspection plan 2: Site = SA

And you receive the product PA in the site SA, your system will select inspection plan 1, because product takes priority over site.

The following table shows the access sequence to inspection plans with priorities from 1 to 16. The ✓s mark the key parameters that have been selected:

# Inspection Plan Decision Table

Requirements											Decisions	
Manually	Automatically										Choose Planned Inspection	Create new Unplanned Inspection
	Assigned quality documents	Assigned quality codes	Sampling Procedure	Inspection Instructions	Key Parameters							
					Priority	Product	Product Category	Site	Supplier, or customer, or			
√	–	–	–	–	–	–	–	–	–	–	x	√
x	√	x	x	x	x	x	x	x	x	x	x	x
x	√	√	x	x	x	x	x	x	x	x	x	x
x	√	√	√	x	x	x	x	x	x	x	x	x
x	√	√	√	√	x	x	x	x	x	x	x	x
x	√	√	√	√	1	√	√	√	√	√	Plan A with priority 1	x
x	√	√	√	√	2	√	√	√	√	√	Plan B with priority 2	x
x	√	√	√	√	3	√	√	√	√	√	Plan C with priority 3	x
x	√	√	√	√	4	√	√	√	√	√	Plan D with priority 4	x
x	√	√	√	√	5	√	√	√	√	√	Plan E with priority 5	x
x	√	√	√	√	6	√	√	√	√	√	Plan F with priority 6	x
x	√	√	√	√	7	√	√	√	√	√	Plan G with priority 7	x
x	√	√	√	√	8	√	√	√	√	√	Plan H with priority 8	x
x	√	√	√	√	9	√	√	√	√	√	Plan I with priority 9	x
x	√	√	√	√	10	√	√	√	√	√	Plan J with	x

										priority 10	
x	√	√	√	√	11		√		√	Plan K with priority 11	x
x	√	√	√	√	12		√			Plan L with priority 12	x
x	√	√	√	√	13			√	√	Plan M with priority 13	x
x	√	√	√	√	14			√		Plan N with priority 14	x
x	√	√	√	√	15				√	Plan O with priority 15	x
x	√	√	√	√	16					Plan P with priority 16	x
x	x	x	x	x	x	x	x	x	x	Plan Q	x

#### 10.4.5.2.3 Inspection Scope

An inspection plan specifies an inspection scope. You can select from the following inspection scopes:

- No Inspection Required
- Sample Size Fixed
- Sample Size 100%
- Sample Size Percentage
- Sample Size By Sampling Scheme

#### 10.4.6 DMN Decision Tables: Receiving Decision Table

Here we are going to show the decision logic for whole our receiving process, similar to what we have done for Quality check decision. So we can make our decision tables based on our decision model.

Customer Receipt Confirmation Decision Table				
Requirements				Decisions
Bonded Receipt Decision	Quality Check Decision	New Item Decision	The Product Identification & Validation Decision	
Bonded	Approved	New item was recognized	Identified bonded products	Confirm the custom receipt
Not Bonded	–	–	–	No custom receipt
Bonded	Rejected	–	–	No custom receipt
Bonded	Approved	No new item was recognized	Identified bonded products	Confirm the custom receipt
Bonded	Approved	No new item was recognized	Not bonded	No custom receipt

Bonded Receipt Decision Table		
Requirements		Decisions
Bonded Client Decision	Bonded Shipment Decision	
Bonded	Not bonded	Free Receipt
Not bonded	Bonded	Free Receipt
Not bonded	Not bonded	Free Receipt
Bonded	Bonded	Bonded Receipt

Bonded Client Decision Table	
Requirements	Decisions
Client Information	
Included the information of this client	Bonded client
Didn't include the information of this client	Not bonded client

Bonded Shipment Decision Table	
Requirements	Decisions
Shipment Information	
Included the information of this shipment	Bonded client
Didn't include the information of this shipment	Not bonded client

New Item Decision Table		
Requirements		Decisions
Quality Check Decision	Product data	
Approved	Includes new item	Identify new item
Approved	Doesn't include new item	No new item was recognized
Rejected	-	x

Product Identification and Validation Decision Table		
Requirements		Decisions
New item Decision	GUI knowledge	
√	Validate the loads	Identified bonded products
√	Invalid loads	Not bonded loads
x	-	x

## 10.5 DMN DECISION TABLES: INBOUND PLANNING DECISION TABLES

That is time to provide the actual decision logic for our inbound planning decision model in the form of decision table.

Based on our inbound planning decision model, we will build our decision tables. As we have already seen our inbound planning decision model is as below:

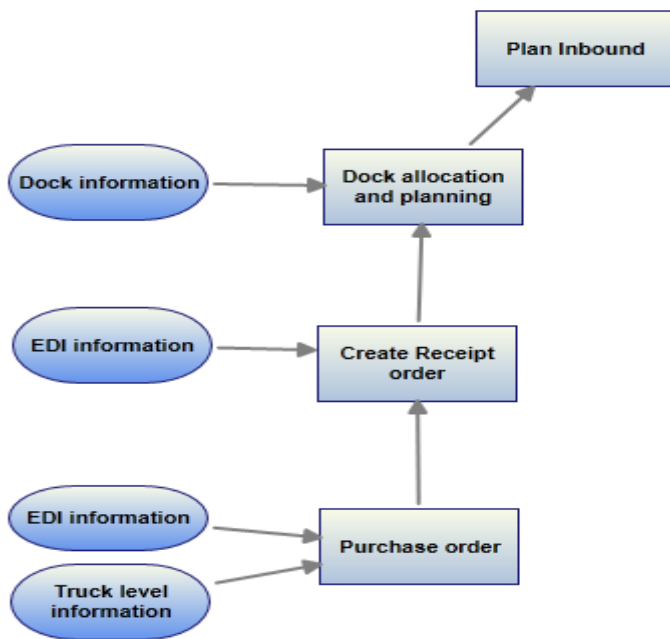

Right now for each block of decisions we are going to provide its decision table based on what was already explained about their attributes and decision description.

Purchase Order Decision Table		
Requirements		Decisions
EDI information	Truck level information	
was checked	included	No need to create purchase order
was checked	Not included	Create purchase order
Was not checked	Not included	×

Receipt Order Decision Table		
Requirements		Decisions
Purchase Order Decision	EDI information	
×	×	No master receipt
√	√	Create master receipt

Dock Planning Decision Table		
Requirements		Decisions
Dock information	Receipt Order Decision	
It includes the plan	Not created	×
It doesn't include the plan	Not included	×
It includes the plan	Created	No dock planning is required
It doesn't include the plan	Created	Dock planning is required

Plan Inbound Decision Table	
Requirements	Decisions
Dock Planning Decision	
√	Planned inbound process
×	unplanned inbound process

## 10.6 DMN DECISION TABLES: DOCK ALLOCATION DECISION TABLES

Here we decide about the actual decision logic for our Dock allocation decision model in the form of a decision table.

Based on our Dock allocation decision model, we will build our decision tables. As we have already seen our Dock allocation decision model is as below:



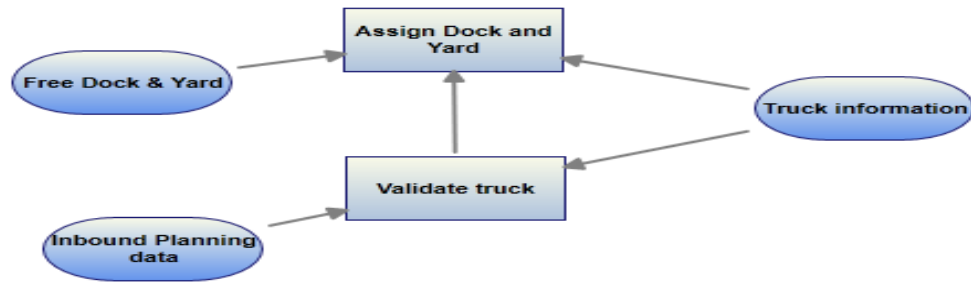

Right now for each block of decisions we are going to provide its decision table based on what was already explained about their attributes and decision description.

Truck Validation Decision Table		
Requirements		Decisions
Inbound planning data	Truck information	
Planned truck	Truck is allowed	Truck is valid
Planned truck	Truck isn't allowed	Reject the truck(invalid)
Unplanned truck	Truck is allowed	Plan the truck and it's valid
Unplanned truck	Truck isn't allowed	Reject the truck(invalid)

Dock & Yard Assignment Decision Table			
Requirements			Decisions
Truck Validation Decision	Free dock & yard information	Truck information	
Valid	Provided	Provided	Assign dock and yard
Valid	Not provided	Provided	No assignment
valid	Provided	Not provided	No assignment
valid	Not provided	Not provided	No assignment
invalid	Provided	Provided	No assignment
invalid	Provided	Not provided	No assignment
invalid	Not provided	Provided	No assignment

# 11 WHAT WE HAVE LEARNED! WHAT IS THE CONNECTION BETWEEN THOSE PROCESSES AND DECISIONS?

---

In this chapter we are going to answer our research questions based on what we have learned in our case study and throughout this paper.

## 11.1 CAN THE DECISION MODELER IMPROVE PROCESSES?

As we have seen in our case study, to discover all decisions, we need to inspect the process.

But at that time because our look was targeted at discovering decisions we found some errors throughout the process which until then have not been revealed. From this we can conclude that the decision modeler helped us to improve the processes.

In the first version of Inbound planning process by DHL, there were a lot of gateways in our business process. That makes our models too complicated. Maybe a question has been raised here; why were they using a lot of gateways? The answer to this question may lead us to find out how decision modeling improve our business processes. While we are modeling our business process and at the same time we are thinking about decisions. That makes our business process models inefficient and complicated. Furthermore, decision buried in process and they only evolve with process. So it is hard to model decisions precisely and even share them.

But if we shift some parts of our business process to the decision logic, the business process will be simplified and more focused on processes rather than decisions. As a consequence, we will have independent process and decision changes. A place where decisions linked, but not buried.

## 11.2 ARE THE PROCESSES GUIDELINES FOR DECISION DISCOVERY?

Referring to our case study, by looking at the process and by seeking out places where there are work lists, escalations and critical gateways we can conclude the business decisions. The user of the work list who is performing tasks might need to take a decision or escalate an issue at multiple points in the work list. Here we need to use our gateway which acts on the decision. For each of these decisions we will create a Decision object in Decisions First Modeler and then associate it with that process. So gateways and work lists in our process are often the indicators of decisions and they can help us as a guideline to extract and model our decisions.

## 11.3 HOW DMN IS CONNECTED TO BPMN

We need to know the link between BPMN and DMN to get the answer of one of the research questions in preface. **'Are decision and process logic independently discovered?'**

Our answer is 'No'.

Basically process discovery without decisions causes inexistence of context for a data element, activity or logic step. So data can be either a process-driver or a portion of a decision or derived from events. Also a gateway can select a pathway for process execution or it can be a part of a decision. That's why there were a lot of gateways in business process which was modeled by DHL in our case

study. Furthermore by ignoring the decision logic, in large projects, the decisions that drive a decision can be intertwined with processes and events.

Actually that's why we treat DMN as an integral notation for process modeling in BPMN. Even though decision model notation is a separate domain within the OMG, the DMN spec provides an explicit way to connect to processes in BPMN. DMN provides a schema model that includes two connection points. First, there is an explicit list that denotes the processes and tasks that use the decisions. Next, DMN provides an input and output data type that implicitly corresponds to the rule activity that invokes the knowledge bases of the decision.

The DMN specification says:

"The interface to the decision service will consist of:

- Input: a list of contexts, providing instances of all the Input Data required by the encapsulated decisions
- Output: a context, providing (at least) the results of evaluating all the decisions in the minimal output set, using the provided instance data.

When the service is called, providing the input, it returns the output. In its simplest form a decision service would always evaluate all decisions in the encapsulation set and return all the results."

Here we are assuming that the decision is created by business rules from input processes and accessed through a decision service. So here we can see the clear link between business process, decisions and BRMS. When a decision service is called the input of our task (it is same as the required data to take a decision in DMN) are processed by the logic defined in the DMN model and the output as a decision is used in downstream activities, events...

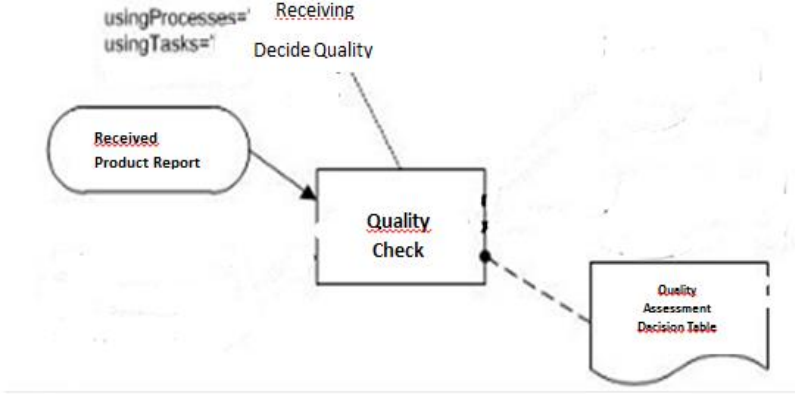

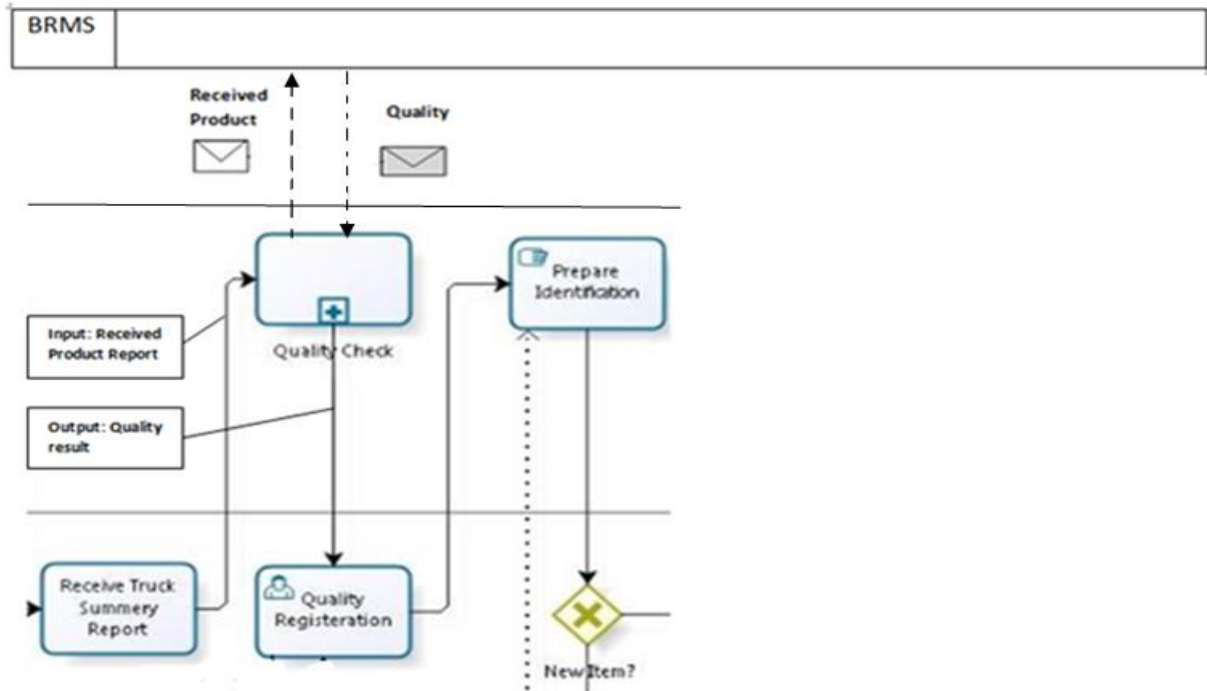

In our case study in receiving process, the received product report is the **input** for the decision of quality check and the **output** is the quality evaluation result. The process in the diagram can be made explicit according to the execution semantics. The above figure shows the usage of the message shape. The association lines (dotted) are used to create the relationship between the message and the data type that is used in the process schema. When decision for a Quality check is requested a received product data message is sent to the decision service. This is an initiating message, so the envelope is white. After the decision is processed by quality assessment decision table and completed, the BRMS returns the quality result. The message is shown as a non-initiating message with light shading.

To summarize: the DMN spec explicitly defines how a BPMN process is connected to the decision through the using Processes and using Tasks metadata for the decision shape. The input and output are attributes of the decision and created by expressions and decision table.

#### 11.4 DECISIONS FIRST MODELING AND KEY PERFORMANCE INDICATORS

Here we are going to answer one of our main research questions was described in the preface. **‘How does DMN help BI?’**

As in chapter one in detail it was explained, BI have become an integral part of organizations decision making strategy. So making better decisions, streamlining work-flows, and providing better customer services should be definite outcome of BI. Besides that, DMN by identifying the decisions that are impacting the performance, and then analyzing what decisions will have the biggest return helps BI. We should note that without Decision Modeling we can't make real efficient decision which affects our KPIs.

Key Performance Indicators are also known as Key Success Indicators, they help an organization to better define and measure their progress toward professional goals. Once an organization has clearly

identified its need, analyzed its mission, and defined its goals it will need a way to measure the progress toward those goals.

Key Performance indicators are those measurements. These indicators are measurements agreed upon beforehand that reflect the critical success factors of a business or organization. They differ depending on the business, the business may decide to appoint the percentage of its income that comes from returning customers as a Key Performance Indicator, or a college may use the rate of students that meet graduations requirements as a Key Performance Indicator, and in our case study that could be the rate of injured products as key Performance Indicator. No matter what Key Performance Indicators are selected they must reflect the business or organization goals.

This means they must be “key” or directly related to its success and they must be measurable. It is also a proficient way to ensure that a company is taking the correct steps toward realizing their goals for the organization’s success. When these indicators are set into place and used to measure what if any impact the decisions made are having on that specific area, the organization can then fine tune the plan of action and take the needed steps that will increase the success, profitability, or productivity of that area.

Business Intelligence applications are one way of monitoring and assessing the level of Key Performance Indicators being met. Business Intelligence systems compile data relating to profit, productivity, customer return, and marketing trends. Also Decision Management Modeling as a significant aspect of BI help us to drive those KPIs and consequently the business objectives. Decision Management is a proven framework that ties business rules to business objectives and Key Performance Indicators or KPIs. A Decision Management approach to business rules begins by looking at business performance drivers, identifying the decisions that are impacting them, then analyzing what decisions will have the biggest return. By focusing on the decisions that matter to an organization—the ones that affect your business drivers and measures—Decision Management simplifies business rules design and implementation, accelerates adoption of a BRMS, focuses a BRMS where it has the highest impact, ensures business ownership of the business rules, and delivers agility and continuous improvement of the decisions across the company.

To clarify the above concept lets go into an example of “**Receiving Process**” in Inbound process from our case study.

#### 11.4.1 Objective: IMPROVE PROCESSES TO ELIMINATE WASTE

Every process and sub process needs to be documented, understood, and followed by all receiving personnel. In further step decisions can be extracted from those processes whether you are receiving a delivery, unloading a **vehicle**, using the right **materials handling equipment**, completing delivery paperwork, sorting and matching items to invoices through to putting stock into your warehouse and cross docking, the receiving function requires the highest level of coordination and discipline to be efficient and effective. Business rules- and Decision process-management not only increases productivity levels, but identifying and documenting process delays will further enhance the overall performance and move towards best practice. The following are core areas of focus to remove process waste:

- 1. Over Stocking**
- 2. Waiting time**
- 3. Unnecessary movement (Materials)**

**4. Over Processing**

**5. Excessive inventory**

**6. Unnecessary movement (People)**

**7. Production of defective products**

So finally by improving our process which targets above objectives, we can easily align our business processes with following business KPIs:

Important KPIs	
Quality, Health & Safety, BCM, Idea Mgt	IFR (Injury Frequency Rate)
	LTA (Number of Total accident)
	Lost Days
	BCM (Business Continuity Management)
	Idea Management (No of new ideas)
	New Rule Adaptability

For instance by focusing on the decisions regarding “quality check” and “checking new items”, some of our KPIs like “IFR (Injury Frequency Rate)” and “LTA (Number of Total accident)” can be affected.

In general by aligning Business rules and KPIs , the capacity for changes can be increased and also IT-Business alignment can be improved.

**11.4.2 Improved alignment**

Given the importance of systems and processes to today’s organization, business and IT professionals must be aligned which is one of the main goals of **BI**. While the IT department plays a critical role in developing, managing and assuring the systems an organization requires, it cannot specify the behavior of those systems. Business owners must be able to effectively collaborate with their IT department to define and manage the behavior of their systems and processes. Processes and systems are aligned when the business and IT have a **shared** understanding of the workflow and the logic in a system, and where the business has the right access, the right level of control, of their systems. Explicitly managing decisions as well as processes allows for this alignment. Furthermore ‘**BCM (Business Continuity Management)**’ KPI can be affected directly by this alignment.

Also we have seen how DMN by improving alignment, increasing the capacity for change and improving the KPIs helps BI to achieve its targets which includes better and easier decision making within an organization.

**11.5 INCREASED CAPACITY FOR CHANGE**

Right now we can go through another research question that has been asked in this paper. ‘Can we be more agile and flexible by integrating process and decision logic?’

In our case study we have seen when we discover a decision and process dependently, we will streamline the processes and improve the visibility. Consequently it helps to have greater analytic agility.

Organizations cannot change more quickly than their systems. To be responsive to change, organizations need to keep their key business parameters visible, understandable and changeable.

Explicitly identifying decisions and describing the logic behind them allows this logic to be parameterized and managed separately from the process itself, dramatically increasing the capacity for change of an organization. Then we can have independent process and decision changes. Also those decisions are reusable. For instance in our case study, quality check as an independent decision has been presented. So changing the quality check decision and procedure doesn't influence our process. Also it can be used as reusable decision in other processes such as outbound process .Finally this increased capacity for change can effect on some of above KPIs; **'New Rule Adaptability' 'Idea Management (No of new ideas)'**.

## 12 REFERENCE:

---

- Michael Chau. Jennifer Xu. BUSINESS INTELLIGENCE IN BLOGS: UNDERSTANDING CONSUMER INTERACTIONS AND COMMUNITIES, MIS Quarterly, December 2012
- Hsinchun Chen. Roger H. L. Chiang. Veda C. Storey. BUSINESS INTELLIGENCE AND ANALYTICS: FROM BIG DATA TO BIG IMPACT, MIS Quarterly, December 2012
- Surajit Chaudhuri. Umeshwar Dayal. Vivek Narasayy. An Overview of Business Intelligence Technology, communications of the acm, august 2011
- Sahay and Jayanthi Ranjan. Real time business intelligence in supply chain analytics, IMCS, 2008
- Coline White, Business Intelligence Automation, Building the smart business, August 2004
- Anca ANDREESCU. Marinela MIRCEA. Managing Knowledge as Business Rules, Informatica Economică, April 2009
- James Taylor. Decision Management Systems – A Practical Guide to Using Business Rules and Predictive Analytics. IBM Press. 2011
- James Taylor. DecisionsFirst Modeler, 2013, URL <http://www.decisionmanagementsolutions.com/attachments/article/270/DecisionsFirstModelerBrochure.pdf>
- International Institute of Business Analysts®. Business Analyst Body of Knowledge® 2.0.
- Object Management Group. Business Process Model and Notation (BPMN) Version 2.0.1 OMG Document Number formal/2013-09-02 Current version at <http://www.omg.org/spec/BPMN/Current>
- Object Management Group. Decision Model and Notation (DMN) Specification 1.0 Submission Current version at <http://www.omg.org/spec/DMN/Current>
- GIL RONEN. Case Study: Mortgage Recommender. Object Management Group, JUNE 2014
- James Taylor. Tom Debevoise. How DMN is connected to BPMN, 2014, URL <http://www.tomdebevoise.com/blog/2014/11/1/by-the-book-how-dmn-is-connected-to-bpmn.html>
- James Taylor. Tom Debevoise. 4 Key Benefits of Integrating BPMN and DMN, 2014, URL <http://www.slideshare.net/jamet123/4-key-benefits-to-integrating-bpmn-and-dmn-webinar>
- James Taylor. Business rules and decisioning for process experts, 2010 More information at: [www.decisionmanagementsolutions.com/learnmore](http://www.decisionmanagementsolutions.com/learnmore)
- Akintola K.G. Adetunmbi A.O. Adeola O.S. BUILDING DATA WAREHOUSING AND DATA MINING FROM COURSE MANAGEMENT SYSTEMS, 2011
- James Polasek. Why you should implement Business Intelligence, Jul 2013, URL <http://www.yellowfinbi.com/YFCommunityNews-Why-you-should-implement-Business-Intelligence-141076>
- Paul Myerson. Supply Chain Analytics: What is it and Why is it so Important? May 2013, URL <http://www.industryweek.com/blog/supply-chain-analytics-what-it-and-why-it-so-important>
- Jon Hazell. Interview with Dr. Rado Kotorov, Vice President of Product Marketing at Information Builders, December 2013, URL <http://www.dashboardinsight.com/news/news-articles/interview-with-dr-rado-kotorov.aspx>
- <http://www.spagoworld.org/xwiki/bin/view/SpagoBI/BIComponents>
- BRMS, Yael Groep, URL <http://www.yaelgroup.com/en/brms>



# Auteursrechtelijke overeenkomst

Ik/wij verlenen het wereldwijde auteursrecht voor de ingediende eindverhandeling:  
**How Business Intelligence and BRMS bring benefits**

Richting: **Master of Management-Management Information Systems**

Jaar: **2015**

in alle mogelijke mediaformaten, - bestaande en in de toekomst te ontwikkelen - , aan de Universiteit Hasselt.

Niet tegenstaand deze toekenning van het auteursrecht aan de Universiteit Hasselt behoud ik als auteur het recht om de eindverhandeling, - in zijn geheel of gedeeltelijk -, vrij te reproduceren, (her)publiceren of distribueren zonder de toelating te moeten verkrijgen van de Universiteit Hasselt.

Ik bevestig dat de eindverhandeling mijn origineel werk is, en dat ik het recht heb om de rechten te verlenen die in deze overeenkomst worden beschreven. Ik verklaar tevens dat de eindverhandeling, naar mijn weten, het auteursrecht van anderen niet overtreedt.

Ik verklaar tevens dat ik voor het materiaal in de eindverhandeling dat beschermd wordt door het auteursrecht, de nodige toelatingen heb verkregen zodat ik deze ook aan de Universiteit Hasselt kan overdragen en dat dit duidelijk in de tekst en inhoud van de eindverhandeling werd genotificeerd.

Universiteit Hasselt zal mij als auteur(s) van de eindverhandeling identificeren en zal geen wijzigingen aanbrengen aan de eindverhandeling, uitgezonderd deze toegelaten door deze overeenkomst.

Voor akkoord,

**Hassanifar, Aida**

Datum: **19/01/2015**