



2014 | Faculty of Sciences



DOCTORAL DISSERTATION



Equivariant Brauer groups and braided bi-Galois objects

Doctoral dissertation submitted to obtain the degree of doctor
of Science: Mathematics, to be defended by:

Jeroen Dello

Promoter: Prof. Dr Yinhuo Zhang



D/2014/2451/32

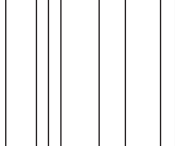

Contents

Acknowledgements	iii
Samenvatting	v
Introduction	ix
Notation and conventions	xvii
1 Preliminaries	1
1.1 Braided monoidal categories	1
1.2 Braided Hopf algebras	7
1.3 The Brauer group of a braided monoidal category	11
1.4 Braided Galois objects	14
2 Braided bi-Galois objects, braided lazy cohomology and monoidal equivalences	19
2.1 A structure theorem for braided bicomodule algebras	20
2.2 Braided bi-Galois objects	31
2.3 Bi-Galois objects over a cocommutative Hopf algebra	41
2.4 Braided lazy cohomology	45
2.5 Bi-Galois objects versus monoidal equivalences	52
3 Extending bi-Galois objects and automorphisms to the Radford biproduct	67
3.1 Extending bi-Galois objects	68
3.2 The image of ξ	82
3.3 Extending (co-outer) automorphisms	98
3.4 The kernel of ξ	100
3.5 Relation to lazy cohomology	101

3.6	An exact sequence relating all 'extending' morphisms	104
3.7	Example	106
4	The Brauer group of a finite quantum group	111
4.1	The Brauer group versus the Brauer-Picard group	112
4.2	Galois objects versus autoequivalences	114
4.3	The Brauer group of a finite quantum group	117
4.4	Relation with the morphism ξ	128
5	The equivariant Brauer group of a cocommutative Hopf algebra	133
5.1	Equivariant Brauer group	134
5.2	Multiplier Hopf algebras	137
5.3	Constructing Galois objects from Azumaya algebras	141
5.4	The group homomorphism $\tilde{\pi}$	156
5.5	Surjectivity of $\tilde{\pi}$	159
5.6	Examples	163
A	Structure theorems for bicomodule algebras	165
A.1	Quasi-Hopf bicomodule algebras	166
A.2	Weak Hopf bicomodule algebras	172
	References	179
	Index	184

Acknowledgements

Over the past years I have received support and encouragement from a great number of individuals. Without their guidance and support, I would not have been able to finish this dissertation.

First of all, I would like to thank my supervisor, Yinhuo Zhang, for his support and patience, for many insightful discussions and useful suggestions.

I would also like to thank the members of the jury for their time, both for reading this thesis and for their presence at the defense.

Furthermore, I would like to state my gratitude to Florin Panaite and his wife Christina for their hospitality during my stay in Bucharest. I'm very thankful to Florin for the many fruitful discussions during our collaborations. His ideas and insights have been of tremendous value during the writing of Chapter 3.

I would like to thank Haixing Zhu for the many interesting conversations during his stay in Hasselt.

I should not forget to mention my colleagues of the Hasselt University, in mathematics and statistics, but also in computer sciences, with a special thanks to Jonny.

On a more personal note I would like to thank all of my friends, just for being who they are and for helping me to take my mind of research every now and then.

Special thanks go out to my parents, for their unconditional support and encouragements and for always believing in me.

Last but certainly not least, I would like to thank my fiancée (soon to be wife) Anneleen, for her love and warmth, for her support and constant patience. She was always there cheering me up and standing by me during the good times and the bad. I can't thank you enough.

Samenvatting

De Brauer groep van een veld is een abelse groep, bestaande uit equivalentieklassen van centrale enkelvoudige algebras. De groep is geïntroduceerd in 1929, maar kent ondertussen verschillende veralgemeningen. De Brauer groep van een braided monoïdale categorie, geïntroduceerd door Van Oystaeyen en Zhang, omvat bijna alle veralgemeningen. Vaak probeert men Brauer groepen te beschrijven met behulp van exacte rijen. Met name de groep van (bi-)Galois objecten keert regelmatig terug in de berekening van een Brauer groep. Dit zullen de twee voornaamste ingrediënten vormen in deze thesis: Brauer groepen en (braided) bi-Galois objecten.

In het eerste deel van de thesis, bestuderen we braided bi-Galois objecten in een braided monoïdale categorie \mathcal{C} . We bewijzen eerst een structuurstelling voor bicomoduul algebras over een braided Hopf algebra B . Zij D een braided bicomoduul algebra zodat er een bilineair, algebra homomorfisme van B naar D is, dan is D als bicomoduul algebra isomorf met het smash product van D^{coB} en B . Het omgekeerde is ook waar. Voor bicomoduul algebras over een quasi-Hopf algebra of een zwakke Hopf algebra kunnen we een gelijkaardige structuurstelling bewijzen. Dit wordt uiteengezet in de appendix. In hoofdstuk 2 gaan we verder met een studie van braided bi-Galois objecten. In het bijzonder tonen we aan dat de groep van bi-Galois objecten over een braided cocommutatieve Hopf algebra beschreven kan worden als het semidirecte product van de groep van Hopf automorfismen en de groep van rechtse B -Galois objecten. Vervolgens beschrijven we een verband tussen de tweede *lazy* cohomologiegroep $H_L^2(\mathcal{C}; B)$ en de groep van bi-Galois objecten $BiGal(\mathcal{C}; B)$ over een braided Hopf algebra B aan de hand van een exacte rij

$$1 \longrightarrow CoOut^-(\mathcal{C}; B) \longrightarrow CoOut(\mathcal{C}; B) \rtimes H_L^2(\mathcal{C}; B) \longrightarrow BiGal(\mathcal{C}; B).$$

Ten slotte tonen we aan dat elke monoïdale equivalentie $\alpha : {}^B\mathcal{C} \rightarrow {}^L\mathcal{C}$, triviaal op \mathcal{C} , aanleiding geeft tot het bestaan van een braided L - H -bi-Galois object in \mathcal{C} .

Zij H een Hopf algebra en zij B een braided Hopf algebra in de categorie

${}^H_H\mathcal{YD}$ van Yetter-Drinfeld modulen. In het derde hoofdstuk construeren we een groepshomomorfisme ξ van de groep van braided bi-Galois objecten over B naar de groep van bi-Galois objecten over het Radford product $B \rtimes H$. Gebruik makend van de structuurstelling uit hoofdstuk 2, kunnen we het beeld van ξ beschrijven als de deelgroep van de bi-Galois objecten D waarvoor er een $B \rtimes H$ -bilineair algebra homomorfisme $H \rightarrow D$ bestaat. Daaropvolgend tonen we aan dat de kern van ξ beschreven kan worden in functie van de kern van een groepshomomorfisme $CoOut(B) \rightarrow CoOut(B \rtimes H)$ (tussen de groepen van co-outer Hopf automorfismen). Vervolgens beschrijven we de relatie met lazy cohomologie. In het bijzonder kunnen we alle groepshomomorfismen met elkaar in verband brengen via volgend commutatief diagram:

$$\begin{array}{ccccccc} 1 & \longrightarrow & CoOut^-(B) & \longrightarrow & CoOut(B) \rtimes H_L^2(B) & \longrightarrow & BiGal(B) \\ & & \downarrow & & \downarrow & & \downarrow \\ 1 & \longrightarrow & CoOut^-(B \rtimes H) & \longrightarrow & CoOut(B \rtimes H) \rtimes H_L^2(B \rtimes H) & \longrightarrow & BiGal(B \rtimes H) \end{array}$$

We sluiten het hoofdstuk af met enkele berekeningen voor Sweedlers Hopf algebra H_4 , die gezien kan worden als een Radford product van $k[X]/(X^2)$ en kC_2 .

In het volgende hoofdstuk gaan we verder met de studie van de Brauer groep $BM(k, H, R)$ van een eindig dimensionale quasitriangulaire Hopf algebra (H, R) . We weten uit [91] dat er een exacte rij

$$1 \longrightarrow Br(k) \longrightarrow BM(k, H, R) \xrightarrow{\tilde{\pi}} Gal^{qc}({}_R H)$$

bestaat. $Gal^{qc}({}_R H)$ is de groep van quantum commutatieve bi-Galois objecten over ${}_R H$, een transmutatie van de quasitriangulaire Hopf algebra (H, R) . De Brauer groep $BM(k, H, R)$ kan gezien worden als de Picard groep $Pic({}_H \mathcal{M})$, i.e. de groep van equivalentieklassen van eenzijdig inversiebele ${}_H \mathcal{M}$ -moduul categorieën. Verder tonen we aan dat de groep $Gal^{qc}({}_R H)$ isomorf is met de groep van braided monoïdale autoequivalenties van de categorie ${}^H_H\mathcal{YD}$, triviaal op ${}^R_H \mathcal{M}$. Aansluitend geven we een nieuwe, categorische interpretatie aan het groepshomomorfisme $\tilde{\pi} : BM(k, H, R) \rightarrow Gal^{qc}({}_R H)$. Het resultaat kunnen we samenvatten in volgend commutatief diagram:

$$\begin{array}{ccccccc} 1 & \longrightarrow & Br(k) & \longrightarrow & BM(k, H, R) & \xrightarrow{\tilde{\pi}} & Gal^{qc}({}_R H) \\ & & \sim \downarrow & & \sim \downarrow & & \downarrow \sim \\ 1 & \longrightarrow & Pic({}_k \mathcal{M}) & \longrightarrow & Pic({}_H \mathcal{M}) & \longrightarrow & Aut_{(A)}^{br}({}^H_H \mathcal{YD}, {}^R_H \mathcal{M}) \end{array}$$

In hoofdstuk 5 veralgemenen we de split exacte rij van Beattie. We berekenen de equivariante Brauer groep van H -moduul algebras voor een cocommutatieve Hopf algebra H , die niet noodzakelijk eindig voortgebracht is. Ter compensatie van de

eventuele *oneindigheid* van H , moeten we werken met Taylor-Azumaya algebras, dit zijn Azumaya algebras die eventueel geen eenheid bezitten. De equivariante Brauer groep $BRM(k, H)$ van H is de groep van Morita equivalentieclassen van Taylor-Azumaya algebras die tegelijkertijd een H -moduul algebra zijn. We tonen het bestaan aan van een exacte rij

$$1 \longrightarrow BR(k) \longrightarrow BRM(k, H) \xrightarrow{\tilde{\pi}} Gal(k, H).$$

Echter, om de surjectiviteit van $\tilde{\pi}$ te bekomen, moeten we veronderstellen dat H een trouwe, surjectieve integraal bezit. Dit laat immers toe om de duale multiplier Hopf algebra \hat{H} te definiëren. Vervolgens tonen we aan dat als B een Galois object is, $B\#\hat{H}$ een H -moduul Taylor-Azumaya algebra is zodat $\pi(B\#\hat{H}) \cong B$. We eindigen het hoofdstuk met enkele voorbeelden.

Ten slotte voorzien we in de appendix het bewijs van de structuurstelling voor bicomoduul algebras over een quasi-Hopf algebra en over een zwakke Hopf algebra.

Introduction

The definition of the Brauer group of a field, introduced by Richard Brauer, goes back to 1929. The Brauer group of a field is an abelian group classifying central simple algebras. The Brauer group of a field was generalized to the Brauer group of a commutative ring by Auslander and Goldman in 1960 [4] (see also [32]). The Brauer group of a commutative ring consists of equivalence classes of central separable algebras. Central separable algebras are also called Azumaya algebras.

Since then, many generalizations have been made in several directions. For example, Wall introduced the Brauer group of \mathbb{Z}_2 -graded algebras, called the Brauer-Wall group, which in his turn has been generalized to gradings by other groups, e.g. in [23]. Another generalization is the so-called Brauer-Long group, that is the Brauer group of dimodule algebras over a finitely generated, projective, commutative and cocommutative Hopf algebra, introduced by Long in [48]. A dimodule is simultaneously a module and a comodule satisfying a certain compatibility condition. One can note that the Brauer-Wall group can be seen as a subgroup of the Brauer-Long group over the group Hopf algebra $k\mathbb{Z}_2$. Caenepeel, Van Oystaeyen and Zhang have generalized the construction by Long and introduced the Brauer group of Yetter-Drinfel'd module algebras [14, 15], hereby disposing the restriction on the Hopf algebra to be finitely generated, projective, commutative and cocommutative. The only requirement is that the antipode is bijective.

All the variations of Brauer groups mentioned above can be seen as particular cases of the Brauer group of a braided monoidal category, which is introduced by Van Oystaeyen and Zhang in 1998 [85]. Note that earlier, before the concept of a braided monoidal category came to life, Pareigis had introduced the Brauer group of a symmetric monoidal category [64].

A common technique to compute the Brauer group is by describing it through the means of an exact sequence, see for example [5, 19, 22, 78] (the list is not exhaustive). In particular, let us consider the Brauer group $BM(k, H)$ of H -module algebras over a finitely generated, projective, cocommutative Hopf algebra. Beattie

showed in [5] that there exists a split exact sequence

$$1 \longrightarrow Br(k) \longrightarrow BM(k, H) \longrightarrow Gal(k, H) \longrightarrow 1$$

where $Br(k)$ is the Brauer group of the commutative ring k and $Gal(k, H)$ is the group of Galois objects, hereby reducing the computation of the Brauer group $BM(k, H)$ to the computation of the groups $Br(k)$ and $Gal(k, H)$. In an attempt to loosen the requirements on the Hopf algebra H , Zhang has shown the existence of a group exact sequence

$$1 \longrightarrow Br(k) \longrightarrow BC(k, H, \mathcal{R}) \longrightarrow Gal^{qc}({}_R H^*)$$

where now (H, \mathcal{R}) is a finitely generated, projective, coquasitriangular Hopf algebra over k [91]. $BC(k, H, \mathcal{R})$ is the Brauer group of H^{op} -comodule algebras and $Gal^{qc}({}_R H^*)$ is the group of isomorphism classes of certain braided bi-Galois objects over the braided Hopf algebra ${}_R H^*$. Here ${}_R H^*$ is a braided Hopf algebra in \mathcal{M}^H obtained from the transmutation process introduced by Majid [52].

These examples clearly show the importance of the study of (braided) bi-Galois theory if we want to study Brauer groups. Therefore the second main ingredient of this dissertation will be braided bi-Galois theory.

Commutative Galois extensions over a Hopf algebra were defined by Chase and Sweedler [21], while Kreimer and Takeuchi later considered not necessarily commutative Galois extensions over a finitely generated, projective Hopf algebra H [46]. A Galois extension A/A^{coH} over a Hopf algebra H is a right H -comodule algebra for which the canonical morphism $can : A \otimes_{A^{coH}} A \rightarrow A \otimes H$ is an isomorphism. Here A^{coH} is the H -coinvariant subalgebra of A . A nice, extensive overview of the theory of Galois extensions (as well as bi-Galois extensions) can be found in [72]. A Galois extension A/k (that is the coinvariant subalgebra A^{coH} is trivial) will be called an H -Galois object.

The set of isomorphism classes of H -Galois objects over a cocommutative Hopf algebra forms a group. The group multiplication is induced by the cotensor product of H -comodules. When H is not cocommutative, it is no longer possible to naturally define a product of two (isomorphism classes of) H -Galois objects. This problem can be overcome by considering bi-Galois objects, introduced by Van Oystaeyen and Zhang for commutative Hopf algebras [84] and generalized by Schauenburg in [68]. If L and H are Hopf algebras, an L - H -bi-Galois object is simultaneously a left L -Galois object and a right H -Galois object making it an L - H -bicomodule. Moreover, it is shown that for a right H -Galois object, there exists a unique Hopf algebra L (up to isomorphism) making A an L - H -bi-Galois object. L is built on the algebra $(A \otimes A)^{coH}$. The isomorphism classes of bi-Galois objects form a groupoid, since it's possible to take the cotensor product of an L - H -bi-Galois object and an H - F -bi-Galois object. The result will be an L - F -bi-Galois object. In particular, the set of H - H -bi-Galois objects will form a group $BiGal(H)$ (this fact was first observed in the unpublished paper [83] by Van Oystaeyen and Zhang and independently proven by Schauenburg in [68]).

Many results of (bi-)Galois theory have been generalized to the case of Hopf algebras in braided monoidal categories. Schauenburg defined braided (bi-)Galois objects and constructed the groupoid of bi-Galois objects over Hopf algebras in a braided monoidal category \mathcal{C} in [73]. This study was continued in [74].

After the preliminary chapter, we present some more generalizations of bi-Galois theory in a categorical setting. We will work over a braided monoidal category \mathcal{C} (which we'll assume to have equalizers whenever needed). By MacLane's coherence theorem, we can and will assume that \mathcal{C} is strict monoidal. This has the advantage that we can make use of graphical calculus.

To be more precise, we'll start Chapter 2 by providing a structure theorem for bicomodule algebras over a Hopf algebra B in a braided monoidal category \mathcal{C} . This is a part of the work done in [28], in which we provide a structure theorem for bicomodule algebras over either a braided Hopf algebra, a quasi-Hopf algebra or a weak Hopf algebra. We will only present the proof for braided bicomodule algebras in this chapter. For the sake of completeness, the two other cases are included in an appendix. We first prove that if A is a Yetter-Drinfeld module over B in \mathcal{C} , then the smash product $A\#B$ is a B -bicomodule algebra in \mathcal{C} and the natural embedding $B \rightarrow A\#B$ is a bicolinear algebra morphism. Consequently, we prove that the converse is also true.

Theorem 1 (Theorem 2.1.9). *Let $(\mathcal{C}, \otimes, I, \phi)$ be a braided monoidal category which admits split idempotents and let $B \in \mathcal{C}$ be a braided Hopf algebra with bijective antipode. Assume B is flat. Suppose D is a B -bicomodule algebra such that there exists a B -bicolinear algebra morphism $v : B \rightarrow D$. Let (D_0, i, p) be a splitting, then $D_0 \in {}_B^B\mathcal{YD}(\mathcal{C})$ is a Yetter-Drinfeld module algebra and $D \cong D_0\#B$ as B -bicomodule algebras.*

We will apply this structure theorem in Chapter 3. In order to compute the group of bi-Galois objects of a braided cocommutative Hopf algebra B in \mathcal{C} (under certain conditions), we will generalize some more known results from the classical Hopf-Galois theory to the categorical setting. We prove that the bi-Galois group over a cocommutative Hopf algebra B is isomorphic to the semi-direct product of the Hopf automorphism group with a certain group of right B -Galois objects.

Let H be a Hopf algebra over a commutative ring k . One can consider the subset of Galois objects with normal basis (that is $A^{coH} \otimes H$ and A are isomorphic as H -comodules and A^{coH} -modules). An H -comodule algebra is a Galois object with normal basis if and only if A is cleft comodule algebra (there exists a convolution invertible right H -comodule morphism $H \rightarrow A$), or equivalently, if and only if A is a cocycle crossed product. Moreover, it was shown by Doi that the isomorphism classes of cleft extensions are described by certain cohomology classes of cocycles [33]. This set does not have to be a group though. The problem is that the convolution product of two 2-cocycles does not have to be a 2-cocycle. We can surpass this problem by considering a certain subset of so-called lazy cocycles, resulting in the (second) lazy

cohomology group $H_L^2(H)$, e.g. [20, 70]. This group is a subgroup of the group of H -bi-Galois objects $BiGal(H)$. Moreover, it is shown in [8] that the groups can be related by the following exact sequence:

$$1 \longrightarrow CoOut^-(H) \longrightarrow CoOut(H) \rtimes H_L^2(H) \longrightarrow BiGal(H).$$

It is known that the construction of the lazy cohomology group can also be generalized to the braided setting, e.g. see [74]. In Section 2.4 we will generalize some more results on braided lazy cohomology groups, in particular we show that the aforementioned sequence can be generalized to the case of a braided Hopf algebra in a braided monoidal category.

Theorem 2 (Theorem 2.4.5). *Let B be a Hopf algebra in a braided monoidal category \mathcal{C} and assume \mathcal{C} has equalizers. There is a group exact sequence*

$$1 \longrightarrow CoOut^-(\mathcal{C}; B) \longrightarrow CoOut(\mathcal{C}; B) \rtimes H_L^2(\mathcal{C}; B) \longrightarrow BiGal(\mathcal{C}; B).$$

We will provide an application of this theorem in Chapter 3. We conclude Chapter 2 by investigating the relation between bi-Galois objects and monoidal autoequivalences of comodule categories trivializable on the base category. If k is a commutative ring and B and L are flat Hopf algebras, it is well known that there exists a one-one correspondence between isomorphism classes of faithfully flat B - L -bi-Galois objects and monoidal isomorphism classes of k -linear monoidal equivalences ${}^B\mathcal{M} \cong {}^L\mathcal{M}$. We generalize this result to the case where the Hopf algebras are in a braided monoidal category.

Theorem 3 (Theorem 2.5.11). *Let $(\mathcal{C}, \otimes, I, \phi)$ be a braided monoidal category. Assume $(\alpha, \varphi_0, \varphi) : {}^B\mathcal{C} \rightarrow {}^L\mathcal{C}$ is a monoidal equivalence functor trivializable on \mathcal{C} (or equivalently, a right \mathcal{C} -module functor) satisfying $\phi \circ \varphi_{X, M} = \varphi_{M, X} \circ \phi$. Then $\alpha(B)$ is a faithfully flat L - B -bi-Galois object.*

In Chapter 3 we will first recall the construction of the Radford biproduct. That is, one can construct a k -Hopf algebra, denoted $B \rtimes H$, from a braided Hopf algebra B in ${}^H_H\mathcal{YD}$ and a k -Hopf algebra H . In [25], Cuadra and Panaite provided a way to extend (lazy) cocycles over the braided Hopf algebra B to (lazy) cocycles over the Radford biproduct, hence constructing a group morphism $H_L^2(B) \rightarrow H_L^2(B \rtimes H)$. Since these two groups both can be viewed as subgroups of the groups of bi-Galois objects, our goal in Section 3.1 is to extend the aforementioned morphism to a morphism between two groups of bi-Galois objects. If A is a braided B -bi-Galois object in ${}^H_H\mathcal{YD}$, we prove that $A \# H$ is a $B \rtimes H$ -bi-Galois object. This construction induces a well-defined group morphism between the group of braided B -bi-Galois objects and the group of $B \rtimes H$ -bi-Galois objects.

Theorem 4 (Theorem 3.1.8). *The map $\xi : BiGal(B) \rightarrow BiGal(B \rtimes H)$ sending an isomorphism class $[A]$ to the class $[A \# H]$ is a well-defined group homomorphism.*

Subsequently, we characterize the image of this morphism ξ . Our approach relies on the Hopf-version of the structure theorem for bicomodule algebras, which is an immediate consequence of Theorem 1.

Theorem 5 (Theorem 3.2.9). *The image of the morphism ξ is the subgroup of $BiGal(B \rtimes H)$ of isomorphism classes represented by those $B \rtimes H$ -bi-Galois objects D for which there exists a $B \rtimes H$ -bilinear algebra morphism $H \rightarrow D$.*

To characterize the kernel of ξ , we first need to show that it is also possible to extend braided (co-outer) Hopf automorphisms of the braided Hopf algebra B to (co-outer) Hopf automorphisms of the Radford biproduct $B \rtimes H$. In particular we obtain a group morphism $CoOut(B) \rightarrow CoOut(B \rtimes H)$. The kernel of the morphism $\xi : BiGal(B) \rightarrow BiGal(B \rtimes H)$ can be related to the kernel of the morphism $CoOut(B) \rightarrow CoOut(B \rtimes H)$.

Theorem 6 (Theorem 3.4.2). *A braided B -bi-Galois object A belongs to the kernel of ξ if A is isomorphic (as a B -bi-Galois extension) to ${}^f B$, for some $f \in Aut_{Hopf}(B)$ for which $f \otimes H \in CoInn(B \rtimes H)$.*

In Section 3.5 the relation with lazy cohomology is briefly described. We also provide a new characterization of the image of the morphism $H_L^2(B) \rightarrow H_L^2(B \rtimes H)$ (note that in [25] neither the image nor the kernel of this morphism has been studied). Let us have another look at the exact sequence from Theorem 2. We can say that this is on the 'braided level'. There exists a similar exact sequence for the k -Hopf algebra $B \rtimes H$. Furthermore, there exist extending morphisms between the groups of co-outer automorphisms, the second lazy cohomology groups and the bi-Galois groups. To relate both exact sequences, we will prove that there is also an extending morphism $CoOut^-(B) \rightarrow CoOut^-(B \rtimes H)$ and that there is a well-defined group morphism $CoOut(B) \rtimes H_L^2(B) \rightarrow CoOut(B \rtimes H) \rtimes H_L^2(B \rtimes H)$. Thereupon we show that we have established a commutative diagram of exact sequences.

Theorem 7 (Theorem 3.6.3). *Let B be a Hopf algebra in the category of left-left Yetter-Drinfeld modules ${}^H_H\mathcal{YD}$. The following diagram commutes:*

$$\begin{array}{ccccccc} 1 & \longrightarrow & CoOut^-(B) & \longrightarrow & CoOut(B) \rtimes H_L^2(B) & \longrightarrow & BiGal(B) \\ & & \downarrow & & \downarrow & & \downarrow \\ 1 & \longrightarrow & CoOut^-(B \rtimes H) & \longrightarrow & CoOut(B \rtimes H) \rtimes H_L^2(B \rtimes H) & \longrightarrow & BiGal(B \rtimes H) \end{array}$$

The diagram above allows us to provide another description of the kernel of the morphism $H_L^2(B) \rightarrow H_L^2(B \rtimes H)$. To illustrate all the results from Chapter 3, we finish the chapter by showing an example with Sweedler's Hopf algebra H_4 , which can be viewed as a Radford biproduct of the braided Hopf algebra $k[X]/(X^2)$ and the group Hopf algebra kC_2 , where C_2 is the cyclic group of order 2.

In Chapter 4 we continue the work done by Zhang in [91]. We start from a slightly different setting though, letting (H, R) be a finite dimensional quasitriangular Hopf algebra over a field k . Zhang's exact sequence is of the following form:

$$1 \longrightarrow Br(k) \longrightarrow BM(k, H, R) \xrightarrow{\tilde{\pi}} Gal^{qc}({}_R H)$$

where $BM(k, H, R)$ is the Brauer group of H -module algebras and $Gal^{qc}({}_R H)$ is the group of quantum commutative ${}_R H$ -bi-Galois objects.

As a first possible step towards showing that the sequence is right exact, we will provide a new characterization of the group morphism $BM(k, H, R) \rightarrow Gal^{qc}({}_R H)$ in terms of the group of braided monoidal autoequivalences of ${}^H_H \mathcal{YD}$ trivializable on ${}^R_H \mathcal{M}$. This idea was inspired by the work of Davydov and Nikshych in [26], where the authors study the Brauer-Picard group of a finite tensor category \mathcal{C} . The Brauer-Picard group of \mathcal{C} is the group of equivalence classes of invertible \mathcal{C} -bimodule categories (see [38]). Moreover they show the existence of a group isomorphism $BrPic(\mathcal{C}) \rightarrow Aut^{br}(\mathcal{Z}(\mathcal{C}))$, where $\mathcal{Z}(\mathcal{C})$ is the Drinfeld center of \mathcal{C} , and $Aut^{br}(\mathcal{Z}(\mathcal{C}))$ is the group of braided autoequivalences of $\mathcal{Z}(\mathcal{C})$. (note: the isomorphism holds when \mathcal{C} is a fusion category, in general, we are not sure whether it's true) If \mathcal{C} is also braided, one can consider the subgroup $Pic(\mathcal{C})$ of $BrPic(\mathcal{C})$ consisting of isomorphism classes of one-sided invertible \mathcal{C} -module categories. There is an isomorphism $Pic(\mathcal{C}) \rightarrow Aut^{br}(\mathcal{Z}(\mathcal{C}), \mathcal{C})$, where the latter is the group of isomorphism classes of braided autoequivalences of $\mathcal{Z}(\mathcal{C})$ trivializable on \mathcal{C} .

In this chapter, we consider the special case where (H, R) is a finite dimensional quasitriangular Hopf algebra and $\mathcal{C} = {}_H \mathcal{M}$. Suppose A is an Azumaya algebra in \mathcal{C} . The category \mathcal{C}_A has a natural structure of a left \mathcal{C} -module category. As observed in [26], the Picard group of \mathcal{C} is isomorphic to the group of Morita equivalence classes of exact Azumaya algebras. For $\mathcal{C} = {}_H \mathcal{M}$, we can show that any Azumaya algebra is exact. We obtain the following:

Proposition 8 (Proposition 4.1.4). *The Picard group of \mathcal{C} is isomorphic to the Brauer group of ${}_H \mathcal{M}$:*

$$Pic({}_H \mathcal{M}) \cong BM(k, H, R).$$

In Section 4.2 we show that the two groups $Gal^{qc}({}_R H)$ and $Aut_{(A)}^{br}({}^H_H \mathcal{YD}, {}^R_H \mathcal{M})$ are isomorphic. The inclusion of $Gal^{qc}({}_R H)$ in $Aut_{(A)}^{br}({}^H_H \mathcal{YD}, {}^R_H \mathcal{M})$ has been proven before by Zhu in [92]. To show that they are in fact isomorphic, we will rely on Theorem 3. We obtain:

Proposition 9 (Proposition 4.2.3). *Let (H, R) be a finite dimensional quasitriangular Hopf algebra. The group of quantum commutative ${}_R H$ -bi-Galois objects is isomorphic to the group of isomorphism classes of braided autoequivalences of ${}^H_H \mathcal{YD}$ trivializable on ${}^R_H \mathcal{M}$ and satisfying $\psi \circ \varphi_{X, M} = \varphi_{M, X} \circ \psi$.*

In Section 4.3, we will provide a new characterization for the morphism $\tilde{\pi} : BM(k, H, R) \rightarrow Gal^{qc}({}_R H)$, resulting in a group morphism $BM(k, H, R) \rightarrow$

$Aut_{(A)}^{br}({}_H^H\mathcal{YD}, {}_H^R\mathcal{M})$. In view of Proposition 8, we obtain a group morphism $Pic({}_H\mathcal{M}) \rightarrow Aut_{(A)}^{br}({}_H^H\mathcal{YD}, {}_H^R\mathcal{M})$. We obtain a commutative diagram as in the following theorem.

Theorem 10 (Theorem 4.3.8). *Assume (H, R) is a finite dimensional quasitriangular Hopf algebra. The following diagram commutes:*

$$\begin{array}{ccccccc} 1 & \longrightarrow & Br(k) & \longrightarrow & BM(k, H, R) & \xrightarrow{\tilde{\pi}} & Gal^{qc}({}_R H) \\ & & \sim \downarrow & & \sim \downarrow & & \downarrow \sim \\ 1 & \longrightarrow & Pic({}_k\mathcal{M}) & \longrightarrow & Pic({}_H\mathcal{M}) & \longrightarrow & Aut_{(A)}^{br}({}_H^H\mathcal{YD}, {}_H^R\mathcal{M}) \end{array}$$

The idea behind relating the morphism $\tilde{\pi}$ to a morphism $Pic({}_H\mathcal{M}) \rightarrow Aut_{(A)}^{br}({}_H^H\mathcal{YD}, {}_H^R\mathcal{M})$ is inspired by [26], but our approach is independent of the one in [26], and they may not be the same. If, however, the two constructions would coincide, we would obtain that the morphism $BM(k, H, R) \rightarrow Gal^{qc}({}_R H)$ is surjective (under suitable conditions). At the moment, this is still an open problem. Note that the morphism $BM(k, H, R) \rightarrow Gal^{qc}({}_R H)$ has a kernel while Davydov and Nikshych obtain an isomorphism $Pic(\mathcal{C}) \rightarrow Aut^{br}(\mathcal{Z}(\mathcal{C}), \mathcal{C})$ in [26]. However, they work over an algebraically closed field (of characteristic 0), in which case the classical Brauer group $Br(k)$ is trivial and hence the morphism $BM(k, H, R) \rightarrow Gal^{qc}({}_R H)$ is already injective.

Finally, in Section 4.4, we will present an alternative approach to obtain a (quantum commutative) braided ${}_R H$ -bi-Galois object from a (braided) monoidal autoequivalence $\alpha : {}_H^H\mathcal{YD} \rightarrow {}_H^H\mathcal{YD}$ trivializable on ${}_H^R\mathcal{M}$, using results from Chapter 3.

Another way to generalize Beattie's exact sequence, is to attack the requirement of H needing to be finitely generated. A first generalization in this direction has been made by Caenepeel, Van Oystaeyen and Zhang in [16]. The authors obtained a split exact sequence

$$1 \longrightarrow Br'(k) \longrightarrow BM'(k, G) \xrightarrow{\tilde{\pi}} Gal(k, G) \longrightarrow 1$$

for any group G . Here k is a commutative ring, $Br'(k)$ is the Taylor-Brauer group, or bigger Brauer group, defined by Taylor in [76]. To ensure the surjectivity of $\tilde{\pi}$, the authors needed to replace the Brauer group $BM(k, G)$ by the bigger Brauer group $BM'(k, G)$. This Brauer group consists of equivalence classes of Azumaya algebras with or without a unit (called Taylor-Azumaya algebras) and on which G acts as a group of automorphisms. In Section 5.1, we will generalize this definition and replace the group G by a (possibly infinite) cocommutative Hopf algebra. First we recall the definition of the bigger Brauer group. Then we can consider equivalence classes of Taylor-Azumaya algebras which are simultaneously an H -module algebra. We will call this group the equivariant Brauer group of the cocommutative Hopf algebra H .

In Section 5.2 we recollect the definition of multiplier (Hopf) algebras. Multiplier Hopf algebras are originally introduced over a field, by Van Daele in [80]. A multiplier Hopf algebra is a non-degenerate k -projective algebra, not necessarily unitary, equipped with a so-called comultiplication morphism $\Delta : A \rightarrow M(A \otimes A)$, where $M(A \otimes A)$ is the multiplier algebra of $A \otimes A$, such that certain endomorphisms on $A \otimes A$ are bijective. A multiplier Hopf algebra with identity is a Hopf algebra and vice versa.

In the next section we will construct an H -Galois object $\pi(A)$ from a k -flat H -module Taylor-Azumaya algebra A . $\pi(A)$ is defined as the centralizer of A in the unitary algebra $M(A\#H)$. This construction induces a well-defined group morphism $\tilde{\pi}$ from the equivariant Brauer group to the group of right H -Galois objects. Note that the latter is a group since H is cocommutative, as discussed before. We are able to compute the kernel, hereby obtaining the main result of Section 5.4.

Theorem 11 (Theorem 5.4.3). *Let k be a commutative ring and H a cocommutative k -projective Hopf algebra. We have an exact sequence*

$$1 \longrightarrow BR(k) \longrightarrow BRM(k, H) \xrightarrow{\tilde{\pi}} Gal(k, H).$$

The next goal is to show the right exactness, or the surjectivity of $\tilde{\pi}$. Let B be an H -Galois object. Beattie's approach would suggest $B\#H^*$ as a preimage. However, as H is not necessarily finitely generated, the dual H^* does not necessarily have to be a Hopf algebra. The theory of multiplier Hopf algebras will offer a solution. A nice property of multiplier Hopf algebras is that the duality can be lifted to the infinite case when H has an integral. In particular, we can consider the dual \hat{H} of the Hopf algebra H which will be a multiplier Hopf algebra. However, as we work over a commutative ring k , we will have to assume that H has a faithful, surjective integral. Note that this assumption was automatically satisfied by the group Hopf algebra kG . Under this assumption we can prove that $B\#\hat{H}$ is an H -module Taylor-Azumaya algebra and that $\pi(B\#\hat{H}) \cong B$, establishing the surjectivity of $\tilde{\pi}$. Thus, we arrive at the main result of Section 5.5.

Theorem 12 (Theorem 5.5.2). *Let k be a commutative ring and H a cocommutative k -projective Hopf algebra with a faithful and surjective integral. We have a split exact sequence*

$$1 \longrightarrow BR(k) \longrightarrow BRM(k, H) \xrightarrow{\tilde{\pi}} Gal(k, H) \longrightarrow 1.$$

We present some examples in Section 5.6. We consider the following cases; k is a field, H is the group Hopf algebra kG , or H is the tensor product of a group Hopf algebra and a finitely generated cocommutative Hopf algebra. For the latter we can consider so-called Hopf orders.

Finally as mentioned before, we conclude the thesis with an appendix containing the proofs of the structure theorems for quasi-Hopf and weak Hopf bicomodule algebras.

Notation and conventions

Throughout the dissertation, k will denote a commutative ring unless otherwise stated. We will reserve the letter H to denote a Hopf algebra over k , except for the appendix, where H will denote a quasi-Hopf algebra or a weak Hopf algebra. Braided Hopf algebras will usually be denoted by B (and L or F if more braided Hopf algebra are considered at the same time).

If H is a k -Hopf algebra, we will use the (sumless) Sweedler notation to denote the comultiplication:

$$\Delta(h) = h_1 \otimes h_2$$

for $h \in H$. For comodules over k -Hopf algebras we will use a (sumless) subscript Sweedler notation. For example if $M \in {}^H\mathcal{M}$, we denote:

$$\lambda(m) = m_{(-1)} \otimes m_{(0)} \in H \otimes M$$

for $m \in M$. We will use different brackets if multiple coactions over different Hopf algebras are considered. In particular, if $M \in \mathcal{M}^{H^*}$ we denote

$$\rho(m) = m_{\{0\}} \otimes m_{\{1\}} \in M \otimes H^*$$

while for a (left) comodule over the Radford biproduct $B \bowtie H$ we will use the following notation:

$$\chi_l(m) = m_{<-1>} \otimes m_{<0>} \in B \bowtie H \otimes M$$

for $m \in M$.

If B is a braided Hopf algebra and if it's possible to write $\Delta(b)$ explicitly for elements $b \in B$ (e.g. when B is a braided Hopf algebra in the category of left-left Yetter-Drinfeld modules ${}^H_H\mathcal{YD}$), we will use the same Sweedler notation as for k -Hopf algebras:

$$\Delta(b) = b_1 \otimes b_2$$

for $b \in B$. However, if N then is a B -comodule, we will use a superscript Sweedler notation to emphasize the fact that the coaction is over a braided Hopf algebra:

$$\chi^-(n) = n^{[-1]} \otimes n^{[0]} \in B \otimes N$$

for $n \in N$.

Chapter 1

Preliminaries

In this first preliminary chapter, we will recall some definitions and results which are needed in this dissertation. We present these concepts in their most general form necessary for this thesis, that is, in the language of braided monoidal categories. Later on, we can always obtain a more precise interpretation of these concepts by specifying the base category.

First we will recall the definition of (braided) monoidal categories. We continue by recollecting the concept of a braided Hopf algebra. Subsequently, we give a description of the Brauer group of a braided monoidal category. Lastly, we look at the definition and some properties of braided Galois objects.

1.1 Braided monoidal categories

For an incisive overview of (braided) category theory, we refer to [50].

Definition 1.1.1. A *monoidal category* is a sextuple $\mathcal{C} = (\mathcal{C}, \otimes, I, a, l, r)$ where

- \mathcal{C} is a category,
- $\otimes : \mathcal{C} \times \mathcal{C} \rightarrow \mathcal{C}$ is a bifunctor, called the *tensor product* of \mathcal{C} ,
- I is an object in \mathcal{C} , called the *unit object* of \mathcal{C} ,
- $a : \otimes \circ (\otimes \times id) \rightarrow \otimes \circ (id \times \otimes)$ is a natural isomorphism, called the *associativity constraint*,
- $l : \otimes \circ (I \otimes id) \rightarrow id$ and $r : \otimes \circ (id \otimes I) \rightarrow id$ are natural isomorphisms, called the *left and right unit constraint* of \mathcal{C} ,

such that the following diagrams commute, for all $U, V, W, X \in \mathcal{C}$:

$$\begin{array}{ccc}
 ((U \otimes V) \otimes W) \otimes X & \xrightarrow{a_{U,V,W} \otimes X} & (U \otimes (V \otimes W)) \otimes X \\
 \downarrow a_{U \otimes V, W, X} & & \downarrow a_{U, V \otimes W, X} \\
 (U \otimes V) \otimes (W \otimes X) & \xrightarrow{a_{U, V, W \otimes X}} & U \otimes ((V \otimes W) \otimes X) \\
 & & \downarrow U \otimes a_{V, W, X} \\
 (U \otimes V) \otimes (W \otimes X) & \xrightarrow{a_{U, V, W \otimes X}} & U \otimes (V \otimes (W \otimes X))
 \end{array}$$

$$\begin{array}{ccc}
 (U \otimes I) \otimes V & \xrightarrow{a_{U, I, V}} & U \otimes (I \otimes V) \\
 \searrow r_U \otimes V & & \swarrow U \otimes l_V \\
 & U \otimes V &
 \end{array}$$

These compatibility diagrams are called the *Pentagon axiom* and the *Triangle axiom*, respectively. If the associativity and left and right unit constraints are given by identities, we say that \mathcal{C} is a *strict monoidal category*. We then use the notation $\mathcal{C} = (\mathcal{C}, \otimes, I)$.

Examples 1.1.2. 1. The category $(\underline{Set}, \times, \{*\})$ is a strict monoidal category, where $\{*\}$ is a fixed singleton.

2. Let k be a commutative ring, the category $({}_k\mathcal{M}, \otimes, k)$ is a strict monoidal category.

Recall from [44] the definition of a braided monoidal category.

Definition 1.1.3. Let \mathcal{C} be a monoidal category and consider the *flip functor* $\tau : \mathcal{C} \times \mathcal{C} \rightarrow \mathcal{C} \times \mathcal{C}$, $\tau(U, V) = (V, U)$ for objects $U, V \in \mathcal{C}$. \mathcal{C} is said to be a *braided monoidal category* if there exists a natural isomorphism $\phi : \otimes \rightarrow \otimes \circ \tau$ satisfying the

two *Hexagon axioms*:

$$\begin{array}{ccccc}
 & & U \otimes (V \otimes W) & \xrightarrow{\phi_{U,V \otimes W}} & (V \otimes W) \otimes U \\
 & \nearrow^{a_{U,V,W}} & & & \searrow^{a_{V,W,U}} \\
 (U \otimes V) \otimes W & & & & & V \otimes (W \otimes U) \\
 & \searrow^{\phi_{U,V} \otimes W} & & & \nearrow^{V \otimes \phi_{U,W}} \\
 & & (V \otimes U) \otimes W & \xrightarrow{a_{V,U,W}} & V \otimes (U \otimes W)
 \end{array}$$

and

$$\begin{array}{ccccc}
 & & (U \otimes V) \otimes W & \xrightarrow{\phi_{U \otimes V,W}} & W \otimes (U \otimes V) \\
 & \nearrow^{a_{U,V,W}^{-1}} & & & \searrow^{a_{W,U,V}^{-1}} \\
 U \otimes (V \otimes W) & & & & & (W \otimes U) \otimes V \\
 & \searrow^{U \otimes \phi_{V,W}} & & & \nearrow^{\phi_{U,W} \otimes V} \\
 & & U \otimes (W \otimes V) & \xrightarrow{a_{U,W,V}^{-1}} & (U \otimes W) \otimes V
 \end{array}$$

for all $U, V, W \in \mathcal{C}$. The morphism ϕ is called the *braiding*. \mathcal{C} is called *symmetric* if there exists a braiding ϕ satisfying the symmetry condition $\phi_{U,V} = \phi_{V,U}^{-1}$ for all $U, V \in \mathcal{C}$.

Definition 1.1.4. Let \mathcal{C} and \mathcal{D} be monoidal categories. A (*lax*) *monoidal functor* from \mathcal{C} to \mathcal{D} consists of a triple (F, φ_0, φ) where

- $F : \mathcal{C} \rightarrow \mathcal{D}$ is a functor,
- $\varphi_0 : I_{\mathcal{D}} \rightarrow F(I_{\mathcal{C}})$ is a \mathcal{D} -morphism,
- $\varphi : \otimes \circ (F, F) \rightarrow F \circ \otimes$ is a natural transformation,

such that the following diagrams commute for all $U, V, W \in \mathcal{C}$:

$$\begin{array}{ccc}
 (F(U) \otimes F(V)) \otimes F(W) & \xrightarrow{a_{F(U), F(V), F(W)}} & F(U) \otimes (F(V) \otimes F(W)) \\
 \downarrow \varphi_{U,V} \otimes F(W) & & \downarrow F(U) \otimes \varphi_{V,W} \\
 F(U \otimes V) \otimes F(W) & & F(U) \otimes F(V \otimes W) \\
 \downarrow \varphi_{U \otimes V, W} & & \downarrow \varphi_{U, V \otimes W} \\
 F((U \otimes V) \otimes W) & \xrightarrow{F(a_{U,V,W})} & F(U \otimes (V \otimes W))
 \end{array}$$

$$\begin{array}{ccc}
 I_{\mathcal{D}} \otimes F(U) & \xrightarrow{l_{F(U)}} & F(U) \\
 \downarrow \varphi_0 \otimes F(U) & & \downarrow F(l_U^{-1}) \\
 F(I_{\mathcal{C}}) \otimes F(U) & \xrightarrow{\varphi_{I,U}} & F(I_{\mathcal{C}} \otimes U)
 \end{array}
 \qquad
 \begin{array}{ccc}
 F(U) \otimes I_{\mathcal{D}} & \xrightarrow{r_{F(U)}} & F(U) \\
 \downarrow F(U) \otimes \varphi_0 & & \downarrow F(r_U^{-1}) \\
 F(U) \otimes F(I_{\mathcal{C}}) & \xrightarrow{\varphi_{U,I}} & F(U \otimes I_{\mathcal{C}})
 \end{array}$$

In addition, if φ_0 and φ are isomorphisms, we say that (F, φ_0, φ) is a *strong monoidal functor*. If φ_0 and $\varphi_{U,V}$ are identities for all $U, V \in \mathcal{C}$, then we call F a *strict monoidal functor*. Assume \mathcal{C} and \mathcal{D} are braided (say with braiding ϕ and ψ respectively). We call F a *braided monoidal functor* if moreover the following diagram commutes

$$\begin{array}{ccc}
 F(U) \otimes F(V) & \xrightarrow{\varphi_{U,V}} & F(U \otimes V) \\
 \downarrow \psi_{F(U) \otimes F(V)} & & \downarrow F(\phi_{U,V}) \\
 F(V) \otimes F(U) & \xrightarrow{\varphi_{V,U}} & F(V \otimes U)
 \end{array}$$

for all $U, V \in \mathcal{C}$.

Suppose (F, φ_0, φ) and $(F', \varphi'_0, \varphi')$ are monoidal functors. A *monoidal natural transformation* between F and F' is natural transformation $\theta : F \rightarrow F'$ such that the following diagrams commute

$$\begin{array}{ccc}
 F(U) \otimes F(V) & \xrightarrow{\varphi_{U,V}} & F(U \otimes V) \\
 \downarrow \theta_{F(U)} \otimes \theta_{F(V)} & & \downarrow \theta_{F(U \otimes V)} \\
 F'(U) \otimes F'(V) & \xrightarrow{\varphi'_{U,V}} & F'(U \otimes V)
 \end{array}$$

$$\begin{array}{ccc}
I_{\mathcal{D}} & \xrightarrow{\varphi_0} & F(I_{\mathcal{C}}) \\
& \searrow \varphi'_0 & \swarrow \theta_I \\
& & F'(I_{\mathcal{C}})
\end{array}$$

for all $U, V \in \mathcal{C}$.

Finally, a (braided) monoidal equivalence between two (braided) monoidal categories \mathcal{C} and \mathcal{D} is given by a (braided) monoidal functor $F : \mathcal{C} \rightarrow \mathcal{D}$ for which there exists a (braided) monoidal functor $G : \mathcal{D} \rightarrow \mathcal{C}$ and natural monoidal isomorphisms $\theta : id_{\mathcal{C}} \rightarrow GF$ and $\theta' : id_{\mathcal{D}} \rightarrow FG$.

Examples 1.1.5. 1. Let k be a commutative ring, the category $({}_k\mathcal{M}, \otimes, k, \tau)$ is a (strict) braided monoidal category. The braiding is given by the tensor flip τ . I.e., if $U, V \in {}_k\mathcal{M}$, then $\tau_{U,V}$ is defined as the isomorphism $\tau_{U,V} : U \otimes V \rightarrow V \otimes U : u \otimes v \mapsto v \otimes u$.

2. Let H be a Hopf algebra over a commutative ring k with a bijective antipode. A k -module M is said to be a *left-left Yetter-Drinfeld module* if M is simultaneously a left H -module and a left H -comodule satisfying one of the following equivalent compatibility relations:

$$(h_1 \cdot m)_{(-1)} h_2 \otimes (h_1 \cdot m)_{(0)} = h_1 m_{(-1)} \otimes h_2 \cdot m_{(0)}$$

or

$$\lambda(h \cdot m) = h_1 a_{(-1)} S(h_3) \otimes h_2 \cdot m_{(0)} \quad (\text{YD})$$

for $m \in M$ and $h \in H$, where we have used the following notation for the left H comodule structure $\lambda : M \rightarrow H \otimes M$, $\lambda(m) = m_{(-1)} \otimes m_{(0)}$.

Consider the category of left-left Yetter-Drinfeld modules, denoted by ${}^H_H\mathcal{YD}$. Morphisms are given by H -linear H -colinear maps. The category ${}^H_H\mathcal{YD}$ is (strict) monoidal. Indeed if $M, N \in {}^H_H\mathcal{YD}$, then $M \otimes N$ is a left-left Yetter-Drinfeld module via the diagonal action and the diagonal coaction:

$$\begin{aligned}
h \cdot (m \otimes n) &= h_1 \cdot m \otimes h_2 \cdot n \\
\lambda(m \otimes n) &= m_{(-1)} n_{(-1)} \otimes m_{(0)} \otimes n_{(0)}
\end{aligned}$$

The category ${}^H_H\mathcal{YD}$ is braided via:

$$\begin{aligned}
\phi(m \otimes n) &= m_{(-1)} \cdot n \otimes m_{(0)} \\
\phi^{-1}(n \otimes m) &= m_{(0)} \otimes S^{-1}(m_{(-1)}) \cdot n
\end{aligned}$$

for $m \in M$, $n \in N$.

3. Let H be a *quasitriangular* Hopf algebra over a commutative ring k , that is, there exists an element $R = \sum R^1 \otimes R^2 \in H \otimes H$, called the *R-matrix*, satisfying the following conditions

$$\sum \varepsilon(R^1)R^2 = \sum R^1\varepsilon(R^2) = 1, \quad (\text{QT1})$$

$$\sum \Delta(R^1) \otimes R^2 = \sum R^1 \otimes r^1 \otimes R^2 r^2, \quad (\text{QT2})$$

$$\sum R^1 \otimes \Delta(R^2) = \sum R^1 r^1 \otimes r^2 \otimes R^2, \quad (\text{QT3})$$

$$\sum R^1 h_1 \otimes R^2 h_2 = \sum h_2 R^1 \otimes h_1 R^2 \quad (\text{QT4})$$

for all $h \in H$, where $r = R$. From now on, we will usually omit the sum sign and write $R = R^1 \otimes R^2$.

Consider the category of H -modules ${}_H\mathcal{M}$. It is monoidal via the diagonal action (as in 2.). Furthermore, ${}_H\mathcal{M}$ is braided via:

$$\begin{aligned} \psi(m \otimes n) &= R^2 \cdot n \otimes R^1 \cdot m \\ \psi^{-1}(n \otimes m) &= S(R^1) \cdot m \otimes R^2 \cdot n \end{aligned}$$

for $m \in M, n \in N$.

If M is an H -module, the R -matrix induces a left H -comodule structure on M via:

$$\lambda(m) = R^2 \otimes R^1 \cdot m \quad (1.1.1)$$

for $m \in M$ and $h \in H$. The original H -action together with this H -coaction turns M into a left-left Yetter-Drinfeld module. Denote by ${}^R_H\mathcal{M}$ the category of left H -modules with the left H -coaction coming from the R -matrix as in (1.1.1). Then ${}^R_H\mathcal{M}$ is a full braided monoidal subcategory of ${}^H_H\mathcal{YD}$.

Dually, H is called *coquasitriangular* if there exists a convolution invertible linear map $\mathcal{R} : H \otimes H \rightarrow k$ subject to the following conditions:

$$\mathcal{R}(x \otimes 1) = \mathcal{R}(1 \otimes x) = \varepsilon(x), \quad (\text{CQT1})$$

$$\mathcal{R}(x \otimes yz) = \mathcal{R}(x_1 \otimes z)\mathcal{R}(x_2 \otimes y), \quad (\text{CQT2})$$

$$\mathcal{R}(yz \otimes x) = \mathcal{R}(y \otimes x_1)\mathcal{R}(z \otimes x_2), \quad (\text{CQT3})$$

$$\mathcal{R}(x_1 \otimes y_1)x_2y_2 = \mathcal{R}(x_2 \otimes y_2)y_1x_1 \quad (\text{CQT4})$$

for $x, y, z \in H$. If (H, \mathcal{R}) is coquasitriangular, the category of right H -comodules is braided with braiding given by

$$\begin{aligned} \psi'(m \otimes n) &= n_{(0)} \otimes m_{(0)}\mathcal{R}(m_{(1)} \otimes n_{(1)}) \\ \psi'(n \otimes m) &= m_{(0)} \otimes n_{(0)}\mathcal{R}^{-1}(m_{(1)} \otimes n_{(1)}) \end{aligned}$$

If H is faithfully projective over k , then (H, R) is quasitriangular if and only if (H^*, \mathcal{R}) is coquasitriangular, where $\mathcal{R}(p \otimes q) = p(R^1)q(R^2)$ for $p, q \in H^*$. Moreover we can naturally identify ${}_H\mathcal{M} = \mathcal{M}^{H^*}$ as braided monoidal categories. In like manner we have ${}^R_H\mathcal{M} = \mathcal{M}^{H^*}$ as braided monoidal subcategories of ${}^H_H\mathcal{YD}$, where \mathcal{M}^{H^*} is the category of right H^* -comodules with right H^* -action induced by \mathcal{R} as follows

$$m \blacktriangleleft p = m_{\{0\}} \mathcal{R}(m_{\{1\}} \otimes p)$$

for $m \in M$, $M \in \mathcal{M}^{H^*}$ and $p \in H^*$, where $m \mapsto m_{\{0\}} \otimes m_{\{1\}}$ denotes the right H^* -coaction.

4. Let $(\mathcal{C}, \otimes, I, \phi)$ be any braided monoidal category. ϕ^{-1} again defines a braiding on \mathcal{C} . We denote by \mathcal{C}^{rev} the braided monoidal category built on $(\mathcal{C}, \otimes, I)$ equipped with the *reversed braiding* ϕ^{-1} .

The categories presented in Examples 1.1.5 (1-3) are all strict. As a matter of fact, Mac Lane proved in [50] a coherence theorem which states that any monoidal category is equivalent to a strict monoidal category. Joyal and Street showed that the same is true for braided monoidal categories [45]. Therefore, we may and will assume that any (braided) monoidal category we work with throughout this dissertation is strict. A nice advantage of this coherence theorem is that it allows the use of graphical calculus. In the next section we will further explain this concept and introduce notation for (co)algebras and (co)modules in braided monoidal categories.

1.2 Braided Hopf algebras

In this section we recollect the definitions of algebras, coalgebras, Hopf algebras and (co)modules in a braided monoidal category (see [54] for example).

Let $(\mathcal{C}, \otimes, I, \phi)$ be a (strict) braided monoidal category. We will denote the braiding and its inverse by:

$$\phi_{M,N} = \begin{array}{c} M \quad N \\ \frown \quad \smile \\ N \quad M \end{array} \quad \text{and} \quad \phi_{M,N}^{-1} = \begin{array}{c} N \quad M \\ \smile \quad \frown \\ M \quad N \end{array}$$

An *algebra* A in \mathcal{C} is an object A together with morphisms $\eta : I \rightarrow A$ and $\nabla : A \otimes A \rightarrow A$, which we denote by:

$$\eta = \begin{array}{c} \bullet \\ \downarrow \\ A \end{array} \quad \text{and} \quad \nabla = \begin{array}{c} A \quad A \\ \cup \\ A \end{array}$$

called the *unit* and *multiplication*, respectively, such that

$$\begin{array}{c} A \\ \bullet \\ \cup \\ A \end{array} = \begin{array}{c} A \\ | \\ A \end{array} = \begin{array}{c} A \\ \cup \\ \bullet \\ A \end{array}$$

and

$$\begin{array}{c} A \quad A \quad A \\ \cup \quad \cup \\ A \end{array} = \begin{array}{c} A \quad A \quad A \\ \cup \quad \cup \\ A \end{array} \quad (\text{associativity law})$$

By duality, i.e. by reading the above diagrams upside down, we obtain the definition of a coalgebra in \mathcal{C} . That is, *coalgebra* is an object $C \in \mathcal{C}$ together with morphisms

$$\Delta = \begin{array}{c} C \\ \cap \\ C \quad C \end{array} \quad \text{and} \quad \varepsilon = \begin{array}{c} C \\ \bullet \end{array}$$

called the *counit* and *comultiplication*, respectively, such that the following equations are satisfied:

$$\begin{array}{c} C \\ \cap \\ \bullet \\ C \end{array} = \begin{array}{c} C \\ | \\ C \end{array} = \begin{array}{c} C \\ \cap \\ C \end{array}$$

and

$$\begin{array}{c} C \\ \cap \quad \cap \\ C \quad C \quad C \end{array} = \begin{array}{c} C \\ \cap \quad \cap \\ C \quad C \quad C \end{array} \quad (\text{coassociativity law})$$

Let A, B be algebras in \mathcal{C} . An *algebra morphism* $f : A \rightarrow B$ is a \mathcal{C} -morphism satisfying the following conditions:

$$\begin{array}{c} A \quad A \\ \cup \\ \boxed{f} \\ B \end{array} = \begin{array}{c} A \quad A \\ \boxed{f} \quad \boxed{f} \\ \cup \\ B \end{array} \quad \text{and} \quad \begin{array}{c} \bullet \\ \boxed{f} \\ B \end{array} = \begin{array}{c} \bullet \\ | \\ B \end{array}$$

Again, the notion of a *coalgebra morphism* is defined dually.

A *bialgebra* $(B, \nabla, \eta, \Delta, \varepsilon)$ in \mathcal{C} is simultaneously an algebra (B, ∇, η) and a coalgebra (B, Δ, ε) such that Δ and ε are algebra morphisms. Graphically, B satisfies:

$$\begin{array}{c}
 B \quad B \\
 \cup \\
 \cup \\
 B \quad B
 \end{array}
 =
 \begin{array}{c}
 B \quad B \\
 \cup \\
 \cup \\
 \cup \\
 B \quad B
 \end{array}
 \tag{1.2.1}$$

$$\begin{array}{c}
 \bullet \\
 | \\
 \cup \\
 B \quad B
 \end{array}
 =
 \begin{array}{c}
 \bullet \quad \bullet \\
 | \quad | \\
 B \quad B
 \end{array}
 \quad \text{and} \quad
 \begin{array}{c}
 B \quad B \\
 \cup \\
 \bullet
 \end{array}
 =
 \begin{array}{c}
 B \quad B \\
 | \quad | \\
 \bullet \quad \bullet
 \end{array}
 \tag{1.2.2}$$

A *braided Hopf algebra* B is a braided bialgebra together with a morphism $S : B \rightarrow B$ in \mathcal{C} , called the *antipode*, denoted by

$$S = \begin{array}{c} B \\ | \\ \oplus \\ | \\ B \end{array}$$

and satisfying

$$\begin{array}{c} B \\ | \\ \oplus \\ | \\ B \end{array}
 =
 \begin{array}{c} B \\ | \\ \oplus \\ | \\ B \end{array}
 =
 \begin{array}{c} B \\ \bullet \\ | \\ \bullet \\ B \end{array}
 \tag{1.2.3}$$

If S is bijective, we denote its inverse by

$$S^{-1} = \begin{array}{c} B \\ | \\ \ominus \\ | \\ B \end{array}$$

A *bialgebra morphism* is simultaneously an algebra and a coalgebra morphism. As in the case of k -modules (where k is a commutative ring), a *Hopf algebra morphism* is defined as a bialgebra morphism (since any bialgebra morphism is compatible with the antipode).

Let us finish this section with the definition of braided (co)modules in the category \mathcal{C} . If A is an algebra, a *left A -module* M is an object $M \in \mathcal{C}$ together with a morphism $\mu^- : A \otimes M \rightarrow M$, which we will denote as follows:

$$\mu^- = \begin{array}{c} A \quad M \\ \lrcorner \\ M \end{array}$$

such that the following compatibility conditions are fulfilled:

$$\begin{array}{c} A & A & M \\ \cup & | & | \\ & \searrow & \searrow \\ & & M \end{array} = \begin{array}{c} A & A & M \\ & | & | \\ & \searrow & \searrow \\ & & M \end{array} \quad \text{and} \quad \begin{array}{c} M & M \\ \bullet & | \\ | & \\ M & M \end{array} = \begin{array}{c} M \\ | \\ M \end{array}$$

If M, N are two A -modules in \mathcal{C} , we call a morphism $f : M \rightarrow N$ *left A -module morphism* if it satisfies:

$$\begin{array}{c} A & M \\ \searrow & | \\ & \searrow \\ & N \end{array} \begin{array}{c} \boxed{f} \\ | \\ N \end{array} = \begin{array}{c} A & M \\ \searrow & | \\ & \searrow \\ & N \end{array} \begin{array}{c} \boxed{f} \\ | \\ N \end{array}$$

The concepts of *right A -modules* and *right A -module morphisms* are defined symmetrically. In particular, for a right A -module M we denote:

$$\mu^+ = \begin{array}{c} M & A \\ \searrow & | \\ & \searrow \\ & M \end{array}$$

For two algebras A and B an object $M \in \mathcal{C}$ is an *A - B -bimodule* if M is a left A - and a right B -module such that:

$$\begin{array}{c} A & M & B \\ \searrow & | & \searrow \\ & \searrow & \searrow \\ & & M \end{array} = \begin{array}{c} A & M & B \\ \searrow & | & \searrow \\ & \searrow & \searrow \\ & & M \end{array}$$

The category of left (resp. right) A -modules and left (resp. right) A -module morphisms is denoted by ${}_A\mathcal{C}$ (resp. \mathcal{C}_A). The category of A - B -bimodules together with left A -module and right B -module morphisms is denoted by ${}_A\mathcal{C}_B$.

Using the duality principle once more, we obtain the definitions of *(bi)comodules* over a coalgebra C in \mathcal{C} , as well as the definition of *C -comodule morphisms*. For a left or respectively right C -comodule N in \mathcal{C} we denote its C -comodule structure by:

$$\chi^- = \begin{array}{c} N \\ \swarrow & | \\ C & N \end{array} \quad \text{resp.} \quad \chi^+ = \begin{array}{c} N \\ | & \searrow \\ N & C \end{array}$$

while we use ${}^C\mathcal{C}$ (resp. \mathcal{C}^C) to denote the category of left (resp. right) C -comodules in \mathcal{C} . If C, D are coalgebras, ${}^C\mathcal{C}^D$ denotes the category of C - D -bicomodules.

1.3 The Brauer group of a braided monoidal category

In this section we will describe the Brauer group of a braided monoidal category \mathcal{C} , which was introduced by Van Oystaeyen and Zhang in [85]. We will do this for a closed braided monoidal category and with the use of braided diagrams, as in [24].

Definition 1.3.1. A *left dual* of an object X in a monoidal category \mathcal{C} is an object X^* together with morphisms $d_X : I \rightarrow X \otimes X^*$ and $e_X : X^* \otimes X \rightarrow I$ such that

$$\begin{aligned} (X \otimes e_X) \circ (d_X \otimes X) &= id_X \\ (e_X \otimes X^*) \circ (X^* \circ d_X) &= id_{X^*} \end{aligned}$$

A monoidal category is called *(left) rigid* if any object has a left dual object.

Definition 1.3.2. A braided monoidal category \mathcal{C} is called *closed* if the functor $- \otimes X : \mathcal{C} \rightarrow \mathcal{C}$ has a right adjoint for every object $X \in \mathcal{C}$. The right adjoint, called the *inner Hom functor*, will be denoted by $[X, -] : \mathcal{C} \rightarrow \mathcal{C}$. The unit resp. counit of the adjunction is then denoted by $\alpha_X : Id_{\mathcal{C}} \rightarrow [X, - \otimes X]$ resp. $ev_X : [X, -] \otimes X \rightarrow Id_{\mathcal{C}}$ for $X, Y \in \mathcal{C}$.

Note that any rigid category is closed since $- \otimes X^*$ is a right adjoint of the functor $- \otimes X$ for $X \in \mathcal{C}$.

Definition 1.3.3. An object X in a braided monoidal category \mathcal{C} is called *finite* if $[X, I]$ and $[X, X]$ exist and if the canonical morphism $db : X \otimes [X, I] \rightarrow [X, X]$, induced by

$$\begin{array}{ccc} X \otimes [X, I] \otimes X & & \\ \downarrow db \otimes X & \searrow P \otimes ev_{X,I} & \\ [X, X] \otimes X & \xrightarrow{ev_{X,X}} & X \cong X \otimes I \end{array}$$

is an isomorphism.

An object X is called *faithfully projective* if X is finite and the canonical morphism $[X, I] \otimes_{[X, X]} X \rightarrow I$ induced by $ev_{X,I}$ is an isomorphism.

One can show that if $X \in \mathcal{C}$ is finite, then its left dual is given by $[X, I]$.

For the rest of this section, $(\mathcal{C}, \otimes, I, \phi)$ is assumed to be a closed braided monoidal category. As \mathcal{C} is braided, we get that the functor $X \otimes -$ has the same right adjoint $[X, -]$. Let's denote the unit resp. counit of the adjunction $(X \otimes -, [X, -])$ by $\bar{\alpha}_X$ resp. \bar{ev}_X . By construction, we have $\bar{\alpha}_{X,Y} = [X, \phi_{X,Y}^{-1}] \circ \alpha_{X,Y}$ and $\bar{ev}_{X,Y} = ev_{X,Y} \circ \phi_{X,[X,Y]}$ for $X, Y \in \mathcal{C}$.

Let A be an algebra in \mathcal{C} . The *opposite algebra* \bar{A} equals A as an object in \mathcal{C} but has multiplication given by

$$\nabla_{\bar{A}} = \begin{array}{c} A \quad A \\ \text{---} \\ \text{---} \\ \text{---} \\ \text{---} \\ \text{---} \\ \text{---} \\ \text{---} \\ \text{---} \\ \text{---} \\ \text{---} \\ A \end{array}$$

Consider the following morphism F defined as the composition:

$$F : A \otimes \bar{A} \xrightarrow{\alpha_{A, A \otimes \bar{A}}} [A, (A \otimes \bar{A}) \otimes A] \xrightarrow{[A, f]} [A, A]$$

where $f = \nabla_A \circ (\nabla_A \otimes A) \circ (A \otimes \phi)$. Similarly, let $g = \nabla_A \circ (A \otimes \nabla_A) \circ (\phi \otimes A)$ and define the morphism

$$G : \bar{A} \otimes A \xrightarrow{\bar{\alpha}_{\bar{A}, \bar{A} \otimes A}} [A, A \otimes (\bar{A} \otimes A)] \xrightarrow{[A, g]} [\bar{A}, \bar{A}]$$

Equivalently F and G are defined as follows

$$\begin{array}{c} A \otimes \bar{A} \quad A \\ \boxed{F} \\ \text{---} \\ \boxed{ev} \\ \text{---} \\ A \end{array} = \begin{array}{c} A \quad \bar{A} \quad A \\ \text{---} \\ \text{---} \\ \text{---} \\ \text{---} \\ \text{---} \\ \text{---} \\ \text{---} \\ \text{---} \\ A \end{array}$$

and

$$\begin{array}{c} A \quad \bar{A} \otimes A \\ \text{---} \\ \boxed{G} \\ \text{---} \\ \boxed{ev} \\ \text{---} \\ A \end{array} = \begin{array}{c} A \quad \bar{A} \quad A \\ \text{---} \\ \text{---} \\ \text{---} \\ \text{---} \\ \text{---} \\ \text{---} \\ \text{---} \\ \text{---} \\ A \end{array}$$

Definition 1.3.4. An algebra A in \mathcal{C} is called an *Azumaya algebra* if A is faithfully projective and the morphisms F and G are isomorphisms. F and G are called the *Azumaya defining morphisms*.

Remark 1.3.5. If \mathcal{C} is symmetric, then F and G coincide.

The following statements are shown in [85, Theorem 3.3].

Proposition 1.3.6. *Let \mathcal{C} be a closed braided monoidal category. Then*

- *If $X \in \mathcal{C}$ is faithfully projective, then $[X, X]$ is an Azumaya algebra in \mathcal{C} ,*
- *If A is an Azumaya algebra in \mathcal{C} , so is \bar{A} ,*
- *If A and B are Azumaya algebras in \mathcal{C} , so is $A \otimes B$.*

Two Azumaya algebras A and B in \mathcal{C} are said to be *Brauer equivalent*, denoted by $A \sim B$, if there exists faithfully projective objects X and Y in \mathcal{C} such that

$$A \otimes [X, X] \cong B \otimes [Y, Y]$$

as algebras. This defines an equivalence relation in the set $B(\mathcal{C})$ of isomorphism classes of Azumaya algebras in \mathcal{C} .

Definition 1.3.7. Let \mathcal{C} be a closed braided monoidal category. The *Brauer group* of \mathcal{C} is defined as the quotient set $Br(\mathcal{C}) = B(\mathcal{C})/\sim$. It is a group with product induced by the tensor product \otimes , unit given by the class of $[I]$, or of $[X, X]$ for any faithfully projective object X in \mathcal{C} , and the inverse of $[A]$ is given by $[\bar{A}]$.

Remark 1.3.8. Let A and B be two algebras in \mathcal{C} . The category of A - B -bimodules in \mathcal{C} is isomorphic to the category of left $A \otimes \bar{B}$ -modules. Indeed, an A - B -bimodule M is a left $A \otimes \bar{B}$ -module via

On the other hand, a left $A \otimes \bar{B}$ -module N becomes an A - B -bimodule as follows

Similarly we obtain that ${}_A\mathcal{C}_B$ is isomorphic to $\mathcal{C}_{\bar{A} \otimes B}$.

An algebra A is naturally an A -bimodule (via multiplication), hence $A \in {}_{A \otimes A}\bar{\mathcal{C}}$. If $X \in \mathcal{C}$, then naturally $A \otimes X \in {}_{A \otimes A}\bar{\mathcal{C}}$ as well. Thus we can consider the functor $A \otimes - : \mathcal{C} \rightarrow {}_{A \otimes A}\bar{\mathcal{C}}$. Similarly, we obtain a functor $- \otimes A : \mathcal{C} \rightarrow \mathcal{C}_{\bar{A} \otimes A}$. Following [85, Theorem 3.1], we obtain the following equivalent characterization of Azumaya algebras.

Theorem 1.3.9. *An algebra A in \mathcal{C} is an Azumaya algebra if and only if the functors $A \otimes - : \mathcal{C} \rightarrow {}_{A \otimes A}\bar{\mathcal{C}}$ and $- \otimes A : \mathcal{C} \rightarrow \mathcal{C}_{\bar{A} \otimes A}$ are equivalences of categories.*

Let us reconsider the examples from 1.1.5.

Examples 1.3.10. 1. Let k be a commutative ring and let $\mathcal{C} = ({}_k\mathcal{M}, \otimes, k, \tau)$. Then $Br(\mathcal{C}) = Br(k)$, the Brauer group of a commutative ring k (cf. [32]).

2. Let H be a Hopf algebra over a commutative ring k with a bijective antipode. Let \mathcal{C} be the closed braided monoidal category ${}^H_H\mathcal{YD}$ of left-left Yetter-Drinfeld modules. Then $Br(\mathcal{C}) = BQ(k, H)$, the Brauer group of Yetter-Drinfeld H -module algebras [14, 15].
3. Let (H, R) be a quasitriangular Hopf algebra over a commutative ring k . The Brauer group of ${}_H\mathcal{M}$ is denoted by $BM(k, H, R)$. Since we can consider ${}_H\mathcal{M}$ as the subcategory ${}^R_H\mathcal{M}$ of ${}^H_H\mathcal{YD}$, $BM(k, H, R)$ is a subgroup of $BQ(k, H)$.

If H is cocommutative (then H is trivially quasitriangular with $R = 1_H \otimes 1_H$) and we recover the Brauer group $BM(k, H)$ of H -module algebras as introduced by Long [48].

Let (H, \mathcal{R}) be a coquasitriangular Hopf algebra. The Brauer group of $\mathcal{M}^{H^{op}}$ is denoted by $BC(k, H, \mathcal{R})$ and is a subgroup of $BQ(k, H)$.

Finally, suppose (H, R) is quasitriangular and faithfully projective over k . Then $BM(k, H, R) = BC(k, H^*, \mathcal{R})$, where \mathcal{R} is defined as in 1.1.5(3).

1.4 Braided Galois objects

Following [73] we recall the definition of Galois objects in a braided monoidal category with equalizers.

Definition 1.4.1. An object X in \mathcal{C} is called *flat* if tensoring with X preserves equalizers. We say X is *faithfully flat* if tensoring with X reflects isomorphisms.

Let B be a Hopf algebra in \mathcal{C} and consider the category ${}^B\mathcal{C}$ of left B -comodules in \mathcal{C} . It is monoidal via the *diagonal coaction*:

$$\begin{array}{c}
 \begin{array}{c} M \otimes N \\ \diagup \quad \diagdown \\ B \quad M \otimes N \end{array} = \begin{array}{c} M \quad N \\ \diagup \quad \diagdown \\ B \quad M \quad N \end{array}
 \end{array} \tag{1.4.1}$$

Thus we can consider algebras in ${}^B\mathcal{C}$, which we will call *left B -comodule algebras*. In other words, a left B -comodule algebra is a left B -comodule and algebra satisfying:

$$\begin{array}{c}
 \begin{array}{c} A \quad A \\ \diagup \quad \diagdown \\ B \quad A \end{array} = \begin{array}{c} A \quad A \\ \diagup \quad \diagdown \\ B \quad A \end{array} \quad \text{and} \quad \begin{array}{c} \bullet \\ \diagdown \\ B \quad A \end{array} = \begin{array}{c} \bullet \quad \bullet \\ \diagdown \quad \diagdown \\ B \quad A \end{array}
 \end{array} \tag{1.4.2}$$

Similarly, we have that the category of right comodules \mathcal{C}^B is monoidal and we obtain the notion of a *right B -comodule algebra*. Specifically, a right B -comodule algebra A

is an algebra in \mathcal{C}^B and satisfies:

$$\begin{array}{c} \text{A} \quad \text{A} \\ \diagdown \quad \diagup \\ \text{A} \quad \text{B} \end{array} = \begin{array}{c} \text{A} \quad \text{A} \\ \diagdown \quad \diagup \\ \text{A} \quad \text{B} \end{array} \quad \text{and} \quad \begin{array}{c} \bullet \\ \diagdown \\ \text{A} \quad \text{B} \end{array} = \begin{array}{c} \bullet \quad \bullet \\ | \quad | \\ \text{A} \quad \text{B} \end{array} \quad (1.4.3)$$

A *B-bicomodule algebra* is a left and right B -comodule algebra satisfying the additional bicomodule relation:

$$\begin{array}{c} \text{A} \\ \diagdown \quad \diagup \\ \text{B} \quad \text{A} \quad \text{B} \end{array} = \begin{array}{c} \text{A} \\ \diagup \quad \diagdown \\ \text{B} \quad \text{A} \quad \text{B} \end{array}$$

The *cotensor product* $M \square_B N$ of a right B -comodule M and a left B -comodule N in \mathcal{C} is defined as the equalizer of $\chi_M^+ \otimes N$ and $M \otimes \chi_N^-$

$$M \square_B N \longrightarrow M \otimes N \rightrightarrows M \otimes B \otimes N$$

Let A be a B -comodule algebra in \mathcal{C} (with comodule structure denoted by χ^+). The *coinvariant subobject* A^{coB} of A is given by the equalizer of χ^+ and $A \otimes \eta_B$

$$A^{coB} \xrightarrow{\iota} A \rightrightarrows A \otimes B$$

Definition 1.4.2. Let A be a right B -comodule algebra in \mathcal{C} . A is said to be a *right B-Galois object* in \mathcal{C} if $\eta_A : I \rightarrow A$ is the equalizer of χ^+ and $A \otimes \eta_B$ (i.e., $A^{coB} = I$), and the canonical morphism $can_+ = (\nabla_A \otimes B)(A \otimes \chi^+) : A \otimes A \rightarrow A \otimes B$ is an isomorphism. Similarly we can define *left B-Galois objects*.

Let A be a right B -Galois object, let's denote:

$$\gamma = (B \xrightarrow{\eta_{A \otimes B}} A \otimes B \xrightarrow{(can_+)^{-1}} A \otimes A) \quad (1.4.4)$$

The morphism γ , being a partial inverse to can_+ , satisfies several identities, which we will list in the lemma below. Proofs can be found in [73, Remark 3.2 and Lemma 3.4].

Lemma 1.4.3. *Let A be a right B -Galois object in \mathcal{C} . Then:*

$$\text{Diagram (1.4.5)} \quad (1.4.5)$$

$$\text{Diagram (1.4.6)} \quad (1.4.6)$$

$$\text{Diagram (1.4.7)} \quad (1.4.7)$$

$$\text{Diagram (1.4.8)} \quad (1.4.8)$$

$$\text{Diagram (1.4.9)} \quad (1.4.9)$$

$$\text{Diagram (1.4.10)} \quad (1.4.10)$$

Note that (1.4.5) and (1.4.6) are equivalent with saying that the inverse of can^+ is given by

$$(can^+)^{-1} = \text{Diagram}$$

While (1.4.7) resp. (1.4.8) state that $\gamma : B \rightarrow \bar{A} \otimes A$ is a right resp. left B -comodule morphism. Here \bar{A} has left B -comodule structure given by

$$\begin{array}{c}
 A \\
 \begin{array}{c} \diagup \\ \diagdown \end{array} \\
 \ominus \\
 \begin{array}{c} \diagdown \\ \diagup \end{array} \\
 B \quad A
 \end{array}$$

Finally, (1.4.9) and (1.4.10) imply that $\gamma : B \rightarrow \bar{A} \otimes A$ is an algebra morphism.

Chapter 2

Braided bi-Galois objects, braided lazy cohomology and monoidal equivalences

In this chapter, we will have a deeper look into the theory of braided bi-Galois objects. We will start with a study of braided bicomodule algebras and prove a structure theorem. We will give use to this structure theorem in Chapter 3. In the second section, we recall the concept of braided bi-Galois objects and investigate some of their properties. We generalize some well known facts of the case of k -Hopf algebras to the case of Hopf algebras in a braided monoidal category. Subsequently, we can use these results to show that the group of bi-Galois objects of a cocommutative Hopf algebra B is isomorphic to the semi-direct product group of the group of braided Hopf automorphisms of B and some group of right B -Galois objects (introduced by Cuadra and Femic [24]). If B is not necessary cocommutative, we are still able to relate $BiGal(\mathcal{C}; B)$ to the group of co-outer automorphisms of B and the group of lazy 2-cocycles via an exact sequence. This will be the main result of Section 2.4. Finally, in Section 2.5, we will describe the relation between bi-Galois objects and monoidal equivalences of comodule categories.

Throughout this chapter, \mathcal{C} is always assumed to be a strict braided monoidal category.

2.1 A structure theorem for braided bicomodule algebras

In this section, B will denote a braided Hopf algebra with bijective antipode in the category \mathcal{C} . The subcategory ${}_B\mathcal{C}$ of left B -modules in \mathcal{C} , denoted by ${}_B\mathcal{C}$, is monoidal. Indeed, if $M, N \in {}_B\mathcal{C}$, then $M \otimes N \in {}_B\mathcal{C}$ via the *diagonal action*:

$$(2.1.1)$$

An object A in \mathcal{C} is said to be a left B -module algebra if A is a B -module and an algebra in \mathcal{C} , in such a way that its multiplication and unit are B -linear, i.e. A is an algebra in the category ${}_B\mathcal{C}$. Graphically, we have:

$$(2.1.2)$$

For a B -module algebra A , one can define the *smash product* $A\#B$ in \mathcal{C} . As an object, $A\#B = A \otimes B$, while the multiplication is given by:

$$(2.1.3)$$

The unit is given by $\eta_A \otimes \eta_B$. It is well-known (e.g. [55]) that $A\#B$ becomes an algebra in \mathcal{C} in this way.

Let us recall the definition of braided Yetter-Drinfeld modules, also called crossed modules, as introduced by Bespalov in [6].

Definition 2.1.1. A braided left-left Yetter-Drinfeld module (M, μ^-, λ) over B in the category \mathcal{C} is simultaneously a left B -module (M, μ^-) and a left B -comodule (M, λ)

in \mathcal{C} satisfying the following compatibility relation:

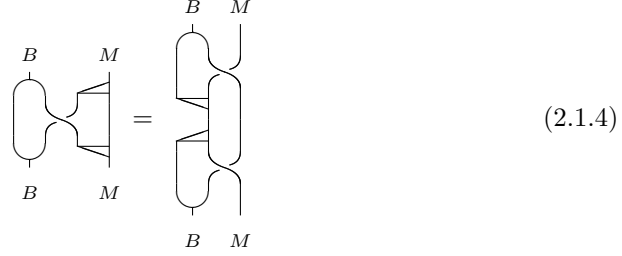

Denote by ${}^B_B\mathcal{YD}(\mathcal{C})$ the category of left-left Yetter-Drinfeld modules in \mathcal{C} (the morphisms are left B -module and left B -comodule morphisms in \mathcal{C}).

Let $M, N \in {}^B_B\mathcal{YD}(\mathcal{C})$; using the diagonal action (2.1.1) and the diagonal coaction (1.4.1), $M \otimes N$ becomes a left-left Yetter-Drinfeld module as well. Hence the category ${}^B_B\mathcal{YD}(\mathcal{C})$ is monoidal. It is also (pre) braided, the braiding and its inverse are given by:

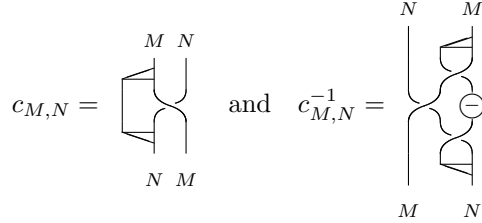

An algebra A in ${}^B_B\mathcal{YD}(\mathcal{C})$ is called a (braided) Yetter-Drinfeld module algebra. Equivalently, $A \in {}^B_B\mathcal{YD}(\mathcal{C})$ is a Yetter-Drinfeld module algebra if it is a left H -module algebra and a left H -comodule algebra.

Proposition 2.1.2. *Let $(\mathcal{C}, \otimes, I, \phi)$ be a braided monoidal category and $B \in \mathcal{C}$ a braided Hopf algebra. Assume that A is a left-left B -Yetter-Drinfeld module algebra. Then the smash product algebra $A \# B$ is a B -bicomodule algebra in the category \mathcal{C} , the structures being given by:*

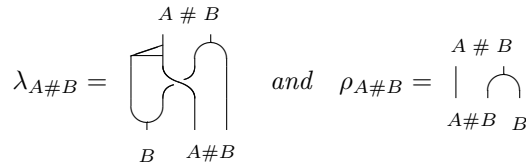

Moreover, the morphism $\eta_A \otimes B : B \rightarrow A \# B$ is a morphism of B -bicomodule algebras.

Proof. Obviously, by the coassociativity of Δ , $A \# B$ is a right B -comodule. $A \# B$ is

easily seen to be a left B -comodule as well, since

$$(\Delta \otimes A\#B) \circ \lambda_{A\#B} =$$

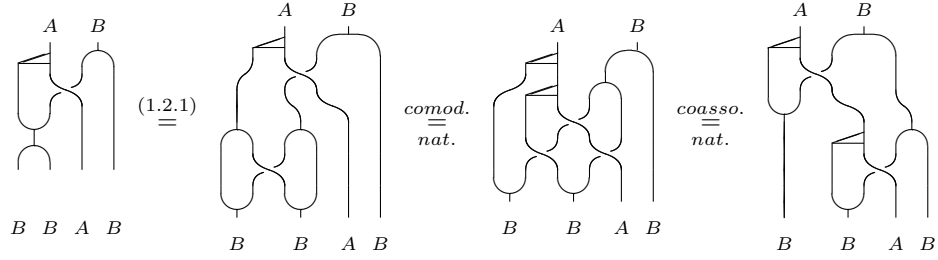

$$= (B \otimes \lambda_{A\#B}) \circ \lambda_{A\#B}$$

Again by coassociativity, $A\#B$ becomes a B -bicomodule. As it is straightforward to verify that $A\#B$ becomes a right B -comodule algebra, the only thing that remains to be proved is the fact that $A\#B$ is a left B -comodule algebra. We verify:

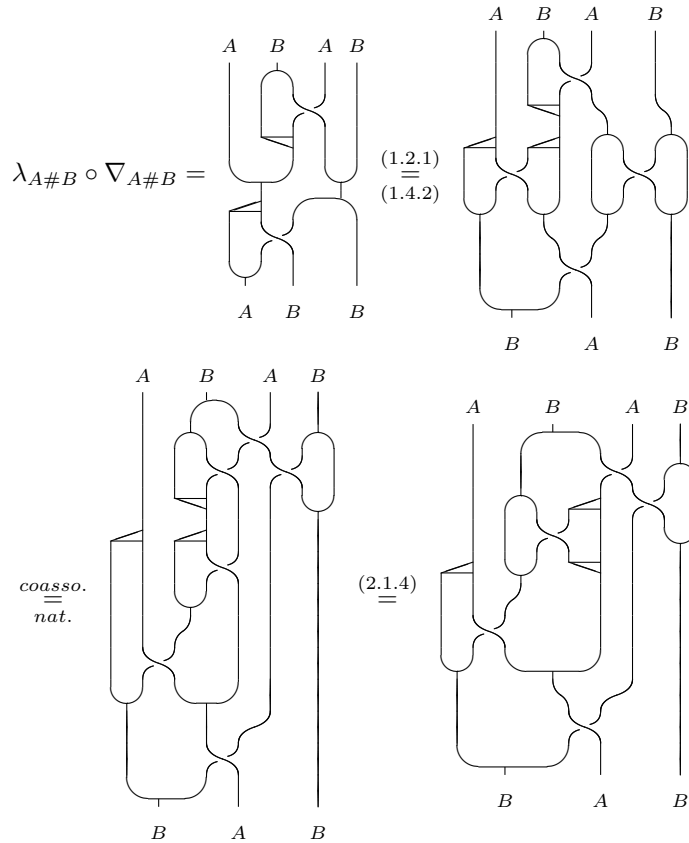

$= \nabla_{A\#B} \circ (\lambda_{A\#B} \otimes \lambda_{A\#B})$

It is straightforward to verify that the morphism $\eta_A \otimes B : B \rightarrow A\#B$ is a morphism of B -bicomodule algebras. \square

The aim of the remaining part of this section is to prove a converse of Proposition 2.1.2. For this we will need the concept of split idempotents.

Definition 2.1.3. An idempotent $e : X \rightarrow X$ in the category \mathcal{C} is said to be *split* if there exists an object $X_e \in \mathcal{C}$ and morphisms $i_e : X_e \rightarrow X$ and $p_e : X \rightarrow X_e$ such that $p_e \circ i_e = id_{X_e}$ and $i_e \circ p_e = e$. We say that \mathcal{C} admits split idempotents if any idempotent in \mathcal{C} is split.

Note that any category \mathcal{C} can be embedded in a category $\hat{\mathcal{C}}$, also denoted $Split(\mathcal{C})$, which admits split idempotents. $\hat{\mathcal{C}}$ is called the *Karoubi enveloping category* of \mathcal{C} . If \mathcal{C} is (braided) monoidal, so is $\hat{\mathcal{C}}$ (cf. [49]).

For the remainder of this section, we will assume that the braided monoidal category \mathcal{C} admits split idempotents. Moreover, splittings are chosen as described in [7, Appendix A].

Recall the notion of a Hopf module in \mathcal{C} .

Definition 2.1.4. Let A be a right B -comodule algebra. A *Hopf module* $D \in \mathcal{C}_A^B$ is a right A -module (D, μ^+) and a right B -comodule (D, ρ) in \mathcal{C} such that the module structure μ^+ on D is a B -comodule morphism, where $D \otimes A$ is equipped with the codiagonal structure, i.e.,

In other words, the right A -action on D is B -colinear.

In the particular case when $(A, \chi^+) = (B, \Delta)$ we call D a *right B -Hopf module*.

We state the following proposition for later use.

Proposition 2.1.5 ([73, Proposition 3.8]). *Let A be a flat right B -Galois object in \mathcal{C} . Then for every Hopf module D in \mathcal{C}_A^B the morphism*

$$\mu_0 : D^{coB} \otimes A \longrightarrow D$$

is an isomorphism.

Let us recall the definition of two-fold Hopf (bi-)modules from [7].

Definition 2.1.6. A *two-fold Hopf module* D is an object in \mathcal{C} which is at the same time a left-right and a right-right B -Hopf module, or equivalently, D is a B -bimodule in \mathcal{C}^B . The category of two-fold Hopf modules together with B -bilinear and B -colinear morphisms is denoted by ${}^B\mathcal{C}_B^B$.

Finally, D is said to be a *B -Hopf bimodule* if D is a B -bimodule in the monoidal category ${}^B\mathcal{C}^B$. Let ${}^B\mathcal{C}_B^B$ denote the category of B -Hopf bimodules together with B -bilinear H -bilinear morphisms.

If D is a right B -Hopf module, one can consider the morphism $E : D \rightarrow D$ defined by $E = \mu^+ \circ (D \otimes S) \circ \rho$, that is:

$$E = \begin{array}{c} D \\ \left. \begin{array}{c} \diagdown \\ \diagup \end{array} \right\} \oplus \\ D \end{array} \quad (2.1.5)$$

Then, by [7, Proposition 3.2.1], E is an idempotent. By assumption, there exist an object $D_0 \in \mathcal{C}$ and morphisms $i : D_0 \rightarrow D$ and $p : D \rightarrow D_0$ such that:

$$\begin{aligned} p \circ i &= id_{D_0} \\ i \circ p &= E \end{aligned} \quad (2.1.6)$$

In addition, it is shown in [7] that (D_0, i) is the equalizer of ρ and $D \otimes \eta_B$. In other words, D_0 is equal to the coinvariants subobject D^{coB} . Using graphical calculus we obtain:

$$\begin{array}{c} D_0 \\ \boxed{i} \\ \left. \begin{array}{c} \diagdown \\ \diagup \end{array} \right\} \\ D \quad B \end{array} = \begin{array}{c} D_0 \\ \boxed{i} \\ \downarrow \bullet \\ D \quad B \end{array} \quad (2.1.7)$$

(D_0, p) is at the same time also equal to the coequalizer of μ^+ and $D \otimes \varepsilon_B$, that is D_0 is the object of B -invariants. In particular, we have:

$$\begin{array}{c} D \quad B \\ \left. \begin{array}{c} \diagdown \\ \diagup \end{array} \right\} \\ \boxed{p} \\ D_0 \end{array} = \begin{array}{c} D \quad B \\ \downarrow \bullet \\ \boxed{p} \\ D_0 \end{array} \quad (2.1.8)$$

If D is a two-fold Hopf module, one can consider the adjoint B -action on D :

$$ad = \begin{array}{c} B \quad D \\ \text{[Diagram: A box labeled } ad \text{ with two strands from } B \text{ and } D \text{ entering from the top, crossing, and exiting from the bottom. A plus sign is inside the box.]} \\ D \end{array}$$

By [7, Proposition 3.6.2] we have:

$$\begin{aligned} E \circ ad &= E \circ \mu^- = ad \circ (B \otimes E) \\ p \circ ad &= p \circ \mu^- \end{aligned} \tag{2.1.9}$$

This allows us to define a left B -module structure on D_0 , say ad_0 , as follows:

$$ad_0 = \begin{array}{c} B \quad D_0 \\ \text{[Diagram: A box labeled } ad \text{ with a box labeled } i \text{ above it. Two strands from } B \text{ and } D_0 \text{ enter from the top, pass through } i, \text{ then } ad, \text{ and exit through } p \text{ to } D_0.]} \\ D_0 \end{array} = \begin{array}{c} B \quad D_0 \\ \text{[Diagram: A box labeled } ad \text{ with a box labeled } i \text{ above it. Two strands from } B \text{ and } D_0 \text{ enter from the top, cross, pass through } i, \text{ then } ad, \text{ and exit through } p \text{ to } D_0.]} \\ D_0 \end{array} \tag{2.1.10}$$

By construction, we have:

$$i \circ ad_0 = ad \circ (B \otimes i) \tag{2.1.11}$$

The following is a (partial) generalization of [2, Proposition 1.2], where a stronger condition (existence of (co)equalizers in \mathcal{C}) is assumed.

Proposition 2.1.7. *Let $(\mathcal{C}, \otimes, I, \phi)$ be a braided monoidal category and $B \in \mathcal{C}$ a braided Hopf algebra. Let D be a right B -comodule algebra in \mathcal{C} such that there exists a B -colinear algebra morphism $v : B \rightarrow D$. We can consider D_0 as above, which now is a B -module algebra. Furthermore $D \cong D_0 \# B$ as right B -comodule algebras.*

Proof. D becomes a two-fold B -Hopf module via

$$\begin{array}{c} B \quad D \\ \text{[Diagram: A box labeled } v \text{ with two strands from } B \text{ and } D \text{ entering from the top, crossing, and exiting from the bottom.]} \\ D \end{array} = \begin{array}{c} B \quad D \\ \text{[Diagram: A box labeled } v \text{ with two strands from } B \text{ and } D \text{ entering from the top, crossing, and exiting from the bottom.]} \\ D \end{array} \quad \text{and} \quad \begin{array}{c} D \quad B \\ \text{[Diagram: A box labeled } v \text{ with two strands from } D \text{ and } B \text{ entering from the top, crossing, and exiting from the bottom.]} \\ D \end{array} = \begin{array}{c} D \quad B \\ \text{[Diagram: A box labeled } v \text{ with two strands from } D \text{ and } B \text{ entering from the top, crossing, and exiting from the bottom.]} \\ D \end{array} \tag{2.1.12}$$

For example:

$$\begin{array}{c} D \quad B \\ \text{[Diagram: A box labeled } v \text{ with two strands from } D \text{ and } B \text{ entering from the top, crossing, and exiting from the bottom.]} \\ D \quad B \end{array} \stackrel{(2.1.12)}{=} \begin{array}{c} D \quad B \\ \text{[Diagram: A box labeled } v \text{ with two strands from } D \text{ and } B \text{ entering from the top, crossing, and exiting from the bottom.]} \\ D \quad B \end{array} \stackrel{(1.4.3)}{=} \begin{array}{c} D \quad B \\ \text{[Diagram: A box labeled } v \text{ with two strands from } D \text{ and } B \text{ entering from the top, crossing, and exiting from the bottom.]} \\ D \quad B \end{array} = \begin{array}{c} D \quad B \\ \text{[Diagram: A box labeled } v \text{ with two strands from } D \text{ and } B \text{ entering from the top, crossing, and exiting from the bottom.]} \\ D \quad B \end{array} \stackrel{(2.1.12)}{=} \begin{array}{c} D \quad B \\ \text{[Diagram: A box labeled } v \text{ with two strands from } D \text{ and } B \text{ entering from the top, crossing, and exiting from the bottom.]} \\ D \quad B \end{array}$$

where the third equality follows from the right B -colinearity of v . Next, observe that:

(2.1.13)

Let (D_0, i, p) be defined as above, with B -action on D_0 as in (2.1.10). We verify that D_0 becomes a B -module algebra, hence we can consider the smash product algebra $D_0 \# B$. First, there is an algebra structure $\nabla_0 : D_0 \otimes D_0 \rightarrow D_0$ defined by $\nabla_0 = p \circ \nabla \circ (i \otimes i)$. Equivalently, using the fact that (D_0, i) is the equalizer of ρ and $D \otimes \eta_B$, ∇_0 is uniquely defined by the relation:

$$i \circ \nabla_0 = \nabla \circ (i \otimes i) \tag{2.1.14}$$

In order to show that D_0 is a B -module algebra, we have to show:

$$ad_0 \circ (B \otimes \nabla_0) = \text{diagram}$$

Now, the right hand side equals

$$\begin{aligned}
& \nabla_0 \circ (ad_0 \otimes ad_0) \circ (B \otimes \phi_{B,D_0} \otimes D_0) \circ (\Delta \otimes D_0 \otimes D_0) \\
&= p \circ \nabla \circ (i \otimes i) \circ (ad_0 \otimes ad_0) \circ (B \otimes \phi_{B,D_0} \otimes D_0) \circ (\Delta \otimes D_0 \otimes D_0) \quad \text{by def. } \nabla_0 \\
&= p \circ \nabla \circ (ad \otimes ad) \circ (B \otimes i \otimes B \otimes i) \circ (B \otimes \phi_{B,D_0} \otimes D_0) \circ (\Delta \otimes D_0 \otimes D_0) \\
&\hspace{15em} \text{by (2.1.11)} \\
&= p \circ \nabla \circ (ad \otimes ad) \circ (B \otimes \phi_{B,D} \otimes D) \circ (B \otimes B \otimes i \otimes i) \circ (\Delta \otimes D_0 \otimes D_0) \\
&= p \circ \nabla \circ (ad \otimes ad) \circ (B \otimes \phi_{B,D} \otimes D) \circ (\Delta \otimes D \otimes D) \circ (B \otimes i \otimes i) \\
&= p \circ ad \circ (B \otimes \nabla) \circ (B \otimes i \otimes i) \quad \text{by (2.1.13)} \\
&= p \circ ad \circ (B \otimes i) \circ (B \otimes \nabla_0) \quad \text{by (2.1.14)} \\
&= p \circ i \circ ad_0 \circ (B \otimes \nabla_0) \quad \text{by (2.1.11)} \\
&= ad_0 \circ (B \otimes \nabla_0) \quad \text{by (2.1.6)}
\end{aligned}$$

The verification that η_{D_0} is left B -linear is left to the reader. Finally one can verify that $\omega : D_0 \# B \rightarrow D$,

$$\omega = \begin{array}{c} D_0 \quad B \\ \boxed{i} \quad \boxed{v} \\ \cup \\ D \end{array}$$

is a right B -colinear algebra isomorphism, where

$$\omega^{-1} = \begin{array}{c} D \\ \lrcorner \\ \boxed{p} \\ D_0 \quad B \end{array}$$

First, ω is right B -colinear since

$$\begin{array}{c} D_0 \quad B \\ \boxed{i} \quad \boxed{v} \\ \cup \\ D \quad B \end{array} \stackrel{(1.4.3)}{=} \begin{array}{c} D_0 \quad B \\ \boxed{i} \quad \boxed{v} \\ \lrcorner \\ D \quad B \end{array} \stackrel{(2.1.7)}{=} \begin{array}{c} D_0 \quad B \\ \boxed{i} \quad \boxed{v} \\ \cup \\ D \quad B \end{array} = \begin{array}{c} D_0 \quad B \\ \boxed{i} \quad \boxed{v} \\ \cup \\ D \quad B \end{array} \quad (2.1.15)$$

Using (2.1.15), we see that we have:

$$\omega^{-1} \circ \omega = \begin{array}{c} D_0 \quad B \\ \boxed{i} \quad \boxed{v} \\ \cup \\ \boxed{p} \\ D_0 \quad B \end{array} \stackrel{(2.1.15)}{=} \begin{array}{c} D_0 \quad B \\ \boxed{i} \quad \boxed{v} \\ \lrcorner \\ \boxed{p} \\ D_0 \quad B \end{array} \stackrel{(2.1.8)}{=} \begin{array}{c} D_0 \quad B \\ \boxed{i} \\ \boxed{p} \\ D_0 \end{array} \stackrel{(2.1.12)}{=} \begin{array}{c} D_0 \quad B \\ \boxed{i} \\ \boxed{p} \\ D_0 \end{array} \stackrel{(2.1.6)}{=} id_{D_0 \# B}$$

Likewise:

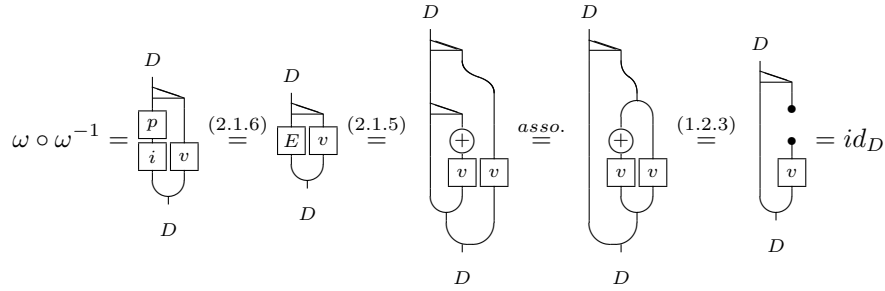

Observe that we have:

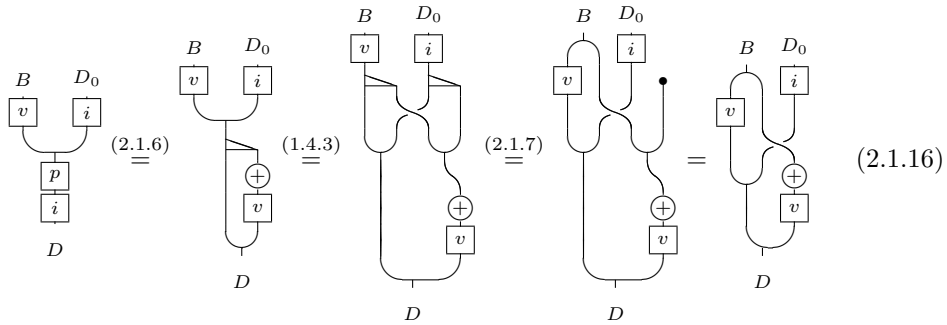

Finally, ω is an algebra morphism since:

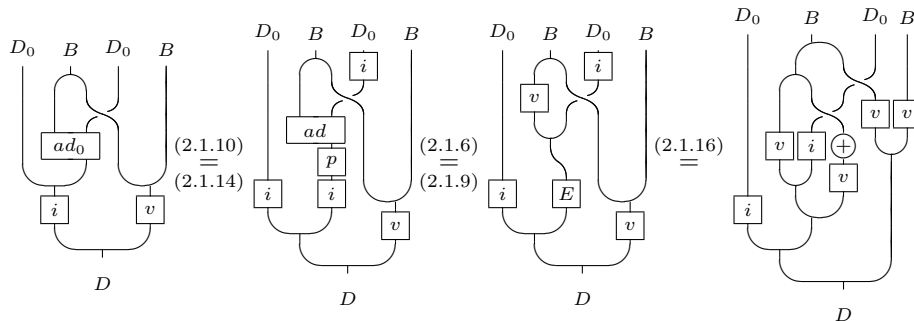

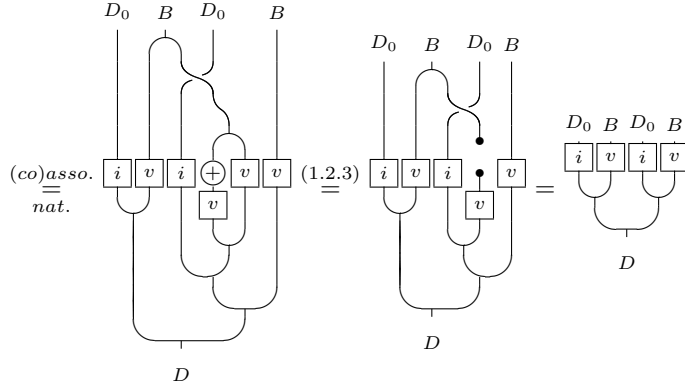

□

The following is a mirror-symmetry version of [7, Theorem 4.3.2].

Theorem 2.1.8. *Let $(\mathcal{C}, \otimes, I, \phi)$ be a braided monoidal category which admits split idempotents and suppose $B \in \mathcal{C}$ is a braided Hopf algebra with bijective antipode. The categories ${}^B_B\mathcal{YD}(\mathcal{C})$ and ${}^B_B\mathcal{C}_B^B$ are braided monoidal equivalent. In particular*

(i) *Let $V \in {}^B_B\mathcal{YD}(\mathcal{C})$, then $V \otimes B \in {}^B_B\mathcal{C}_B^B$ via*

$$\begin{aligned} \mu_{V \otimes B}^- &= \begin{array}{c} B \quad V \otimes B \\ \diagdown \quad \diagup \\ \diagup \quad \diagdown \\ V \otimes B \end{array} & \text{and} & \mu_{V \otimes B}^+ &= \begin{array}{c} V \otimes B \quad B \\ | \quad \cup \\ V \otimes B \end{array} \\ \lambda_{V \otimes B} &= \begin{array}{c} V \otimes B \\ \diagdown \quad \diagup \\ \diagup \quad \diagdown \\ B \quad V \otimes B \end{array} & \text{and} & \rho_{V \otimes B} &= \begin{array}{c} V \otimes B \\ | \quad \cap \\ V \otimes B \quad B \end{array} \end{aligned}$$

(ii) *Let $M \in {}^B_B\mathcal{C}_B^B$, then $M_0 \in {}^B_B\mathcal{YD}(\mathcal{C})$ with B -action induced by the adjoint action, similar as in (2.1.10), and B -coaction inherited from M , that is the B -coaction is defined by the following relation:*

$$\begin{array}{c} M_0 \\ \diagdown \quad \diagup \\ \diagup \quad \diagdown \\ B \quad M \end{array} = \begin{array}{c} M_0 \\ \diagdown \quad \diagup \\ \diagup \quad \diagdown \\ B \quad M \end{array} \quad (2.1.17)$$

We are now able to prove the structure theorem for braided bicomodule algebras.

Theorem 2.1.9. *Let $(\mathcal{C}, \otimes, I, \phi)$ be a braided monoidal category which admits split idempotents and let $B \in \mathcal{C}$ be a braided Hopf algebra with bijective antipode. Assume B is flat. Suppose D is a B -bicomodule algebra such that there exists a B -bilinear algebra morphism $v : B \rightarrow D$. Let (D_0, i, p) be the splitting as in (2.1.6), then $D_0 \in {}^B_B\mathcal{YD}(\mathcal{C})$ is a Yetter-Drinfeld module algebra. The morphism $\omega : D_0 \# B \rightarrow D$ of Proposition 2.1.7 becomes an isomorphism of B -bicomodule algebras.*

Proof. First, D becomes an object in ${}^B_B\mathcal{C}_B^B$ via (2.1.12). Hence, by Theorem 2.1.8, D_0 is an object in ${}^B_B\mathcal{YD}(\mathcal{C})$. On the other hand, by Proposition 2.1.7, we know that D_0 is a left B -module algebra and that ω is a morphism of right B -comodule algebras. Ergo, it suffices to show that D_0 is now also a left B -comodule algebra and that ω is left B -colinear as well. The first statement can be established as follows:

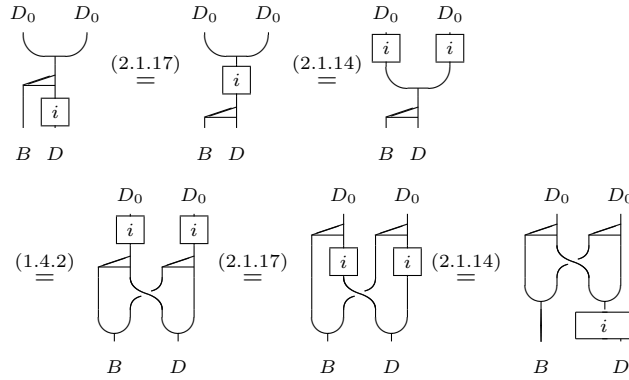

Since B is flat, the functor $B \otimes -$ preserves equalizers. Hence $B \otimes i$ is a monomorphism and by the above computation we may conclude that D_0 is a left B -comodule algebra (the fact that η_{D_0} is B -colinear is easily verified).

To finish the proof, we verify that ω is also left B -colinear. Note that $D_0 \# B$ has the structure of a left B -comodule via

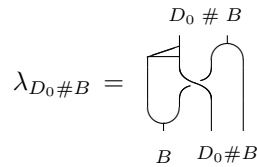

as in Proposition 2.1.2. Then

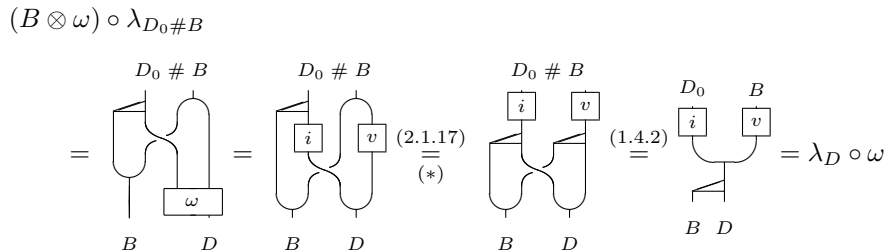

where in (*) we have used the left B -colinearity of v . This concludes the proof. \square

2.2 Braided bi-Galois objects

Assumption 2.2.1. Throughout the rest of this chapter \mathcal{C} is assumed to have equalizers.

Let L and B be flat Hopf algebras in \mathcal{C} .

Definition 2.2.2 ([73, 74]). Let A be an algebra in \mathcal{C} . A is said to be an L - B -bi-Galois object if A simultaneously has the structure of a left L -Galois object and a right B -Galois object making it an L - B -bicomodule algebra.

We will denote the set of isomorphism classes of faithfully flat L - B -bi-Galois objects in \mathcal{C} by $BiGal(\mathcal{C}; L, B)$.

In particular, the set of isomorphism classes of faithfully flat B -bi-Galois objects $BiGal(\mathcal{C}; B)$ forms a group under the cotensor product \square_B .

The following well-known theorem is due to Schauenburg, see [68] for a proof in the classical case or [73] for a proof for braided Hopf algebras.

Theorem 2.2.3. *Let B be a Hopf algebra in \mathcal{C} and let A be a faithfully flat right B -Galois object. Then $L = (A \otimes A)^{coB}$ is a Hopf algebra and there is an L -comodule structure $\chi_L^- : A \rightarrow L \otimes A$ on A making it an L - B -bi-Galois object.*

However, for the braided case, the comultiplication of L is not explicitly given. Rather, its existence is proved using the following universal property of L .

Proposition 2.2.4 ([73, Proposition 4.4]). *Let B be any bialgebra in \mathcal{C} and $\chi : A \rightarrow X \otimes A$ an algebra morphism, then there is a unique algebra morphism $f : L \rightarrow X$ such that $\chi = (f \otimes A) \circ \chi_L^-$.*

Using the above proposition, Δ_L was 'constructed' as the unique algebra morphism satisfying:

$$(\Delta_L \otimes A) \circ \chi_L^- = (L \otimes \chi_L^-) \circ \chi_L^- \quad (2.2.1)$$

We will now give an explicit description for Δ_L . Using this description, we can also prove a slightly stronger version of Proposition 2.2.4.

Suppose A is a faithfully flat right B -Galois object in \mathcal{C} and consider the Hopf module $A \otimes A$, which has A -module and B -comodule structures given by

$$\begin{array}{c} A \otimes A A \\ \text{⌞} \\ A \otimes A \end{array} = \begin{array}{c} A \otimes A \quad A \\ | \quad \cup \\ A \quad A \end{array} \quad \text{and} \quad \begin{array}{c} A \otimes A \\ \text{⌞} \\ A \otimes A B \end{array} = \begin{array}{c} A \quad A \\ \text{⌞} \quad \text{⌞} \\ A \otimes A \quad B \end{array}$$

Let $L = (A \otimes A)^{coB}$ as in Theorem 2.2.3. As the equalizer of $\chi_{A \otimes A}^+$ and $A \otimes A \otimes \eta_B$, L satisfies the following equation:

$$\begin{array}{c} L \\ | \\ \boxed{\iota} \\ | \\ \begin{array}{c} \diagdown \quad \diagup \\ \diagup \quad \diagdown \\ \diagdown \quad \diagup \\ \diagup \quad \diagdown \end{array} \\ | \quad | \\ A \otimes A \quad B \end{array} = \begin{array}{c} L \\ | \\ \boxed{\iota} \\ | \quad | \quad | \\ A \quad A \quad B \end{array} \quad (2.2.2)$$

By Proposition 2.1.5, we get an isomorphism

$$\mu_0 : (A \otimes A)^{coB} \otimes A \longrightarrow A \otimes A$$

From the proof of the structure theorem (in [73]), we can see that the inverse of μ_0 is constructed as follows: first, by flatness of A , we get that $\iota \otimes A : (A \otimes A)^{coB} \otimes A \rightarrow (A \otimes A) \otimes A$ is the equalizer of $\chi_{A \otimes A}^+ \otimes A$ and $A \otimes A \otimes \eta_B \otimes A$. One can show that the morphism

$$\beta = (A \otimes A \xrightarrow{\chi_{A \otimes A}^+} A \otimes A \otimes B \xrightarrow{A \otimes A \otimes \gamma} A \otimes A \otimes A \otimes A \xrightarrow{A \otimes \nabla_A \otimes A} A \otimes A \otimes A)$$

factors through $\iota \otimes A$, inducing a morphism, say $\beta_- : A \otimes A \rightarrow (A \otimes A)^{coB} \otimes A$ such that

$$(\iota \otimes A) \circ \beta_- = \beta$$

Finally, it was shown that β_- is the inverse of μ_0 . Also by [73], the L -comodule structure on A can now be described by:

$$\chi_L^- = \beta_- \circ (A \otimes \eta_A)$$

We now have all the necessary ingredients to give an explicit description for Δ_L . Consider the morphism $G : L \rightarrow (A \otimes A) \otimes (A \otimes A)$,

$$\begin{array}{c} L \\ | \\ \boxed{\iota} \\ | \\ \begin{array}{c} \diagdown \quad \diagup \\ \diagup \quad \diagdown \\ \boxed{\gamma} \\ \diagdown \quad \diagup \\ \diagup \quad \diagdown \end{array} \\ | \quad | \\ A \otimes A \quad A \otimes A \end{array} \quad G =$$

As A is flat, so is $A \otimes A$. Hence, $(A \otimes A)^{coB} \otimes A \otimes A$ is the equalizer of $\chi_{A \otimes A}^+ \otimes A \otimes A$ and $A \otimes A \otimes \eta_B \otimes A \otimes A$. We will verify that

$$(\chi_{A \otimes A}^+ \otimes A \otimes A) \circ G = (A \otimes A \otimes \eta_B \otimes A \otimes A) \circ G$$

showing that G induces a morphism

$$G' : L \rightarrow (A \otimes A)^{coB} \otimes (A \otimes A)$$

such that $G = (\iota \otimes A \otimes A) \circ G'$. Indeed, we see that

$$(\chi_{A \otimes A}^+ \otimes A \otimes A) \circ G$$

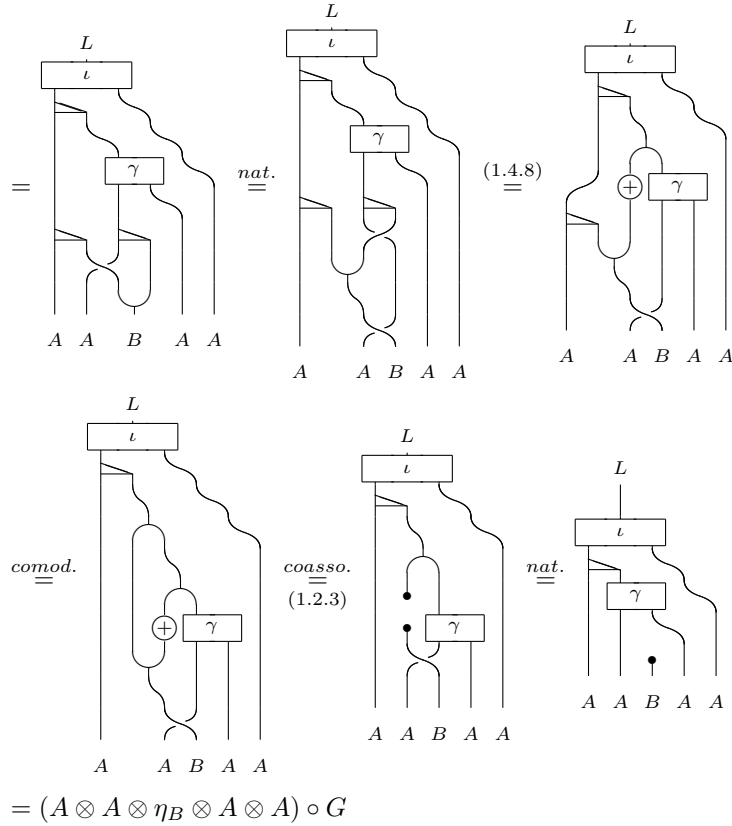

Now, since $L \otimes A \cong A \otimes A$ and A is faithfully flat, $L = (A \otimes A)^{coB}$ is flat too. As a consequence, $(A \otimes A)^{coB} \otimes (A \otimes A)^{coB}$ is the equalizer of $(A \otimes A)^{coB} \otimes \chi_{A \otimes A}^+$ and $(A \otimes A)^{coB} \otimes (A \otimes A \otimes \eta_B)$. We claim that G' induces a morphism

$$\Delta : L \rightarrow (A \otimes A)^{coB} \otimes (A \otimes A)^{coB}$$

satisfying

$$((A \otimes A)^{coB} \otimes \iota) \circ \Delta = G'$$

For this we need to show

$$((A \otimes A)^{coB} \otimes \chi_{A \otimes A}^+) \circ G' = ((A \otimes A)^{coB} \otimes (A \otimes A \otimes \eta_B)) \circ G'$$

Since both A and H are flat, $(A \otimes A)^{coB} \otimes A \otimes A \otimes H$ is the equalizer of $\chi_{A \otimes A}^+ \otimes A \otimes A \otimes H$ and $A \otimes A \otimes \eta_B \otimes A \otimes A \otimes H$, in particular $\iota \otimes A \otimes A \otimes H$ is a monomorphism. Thus it suffices to show

$$\begin{aligned} & (\iota \otimes A \otimes A \otimes H) \circ ((A \otimes A)^{coB} \otimes \chi_{A \otimes A}^+) \circ G' \\ &= (\iota \otimes A \otimes A \otimes H) \circ ((A \otimes A)^{coB} \otimes (A \otimes A \otimes \eta_B)) \circ G' \end{aligned}$$

We compute

$$\begin{aligned} & (\iota \otimes A \otimes A \otimes H) \circ ((A \otimes A)^{coB} \otimes \chi_{A \otimes A}^+) \circ G' \\ &= (A \otimes A \otimes \chi_{A \otimes A}^+) \circ (\iota \otimes A \otimes A) \circ G' \\ &= (A \otimes A \otimes \chi_{A \otimes A}^+) \circ G \end{aligned}$$

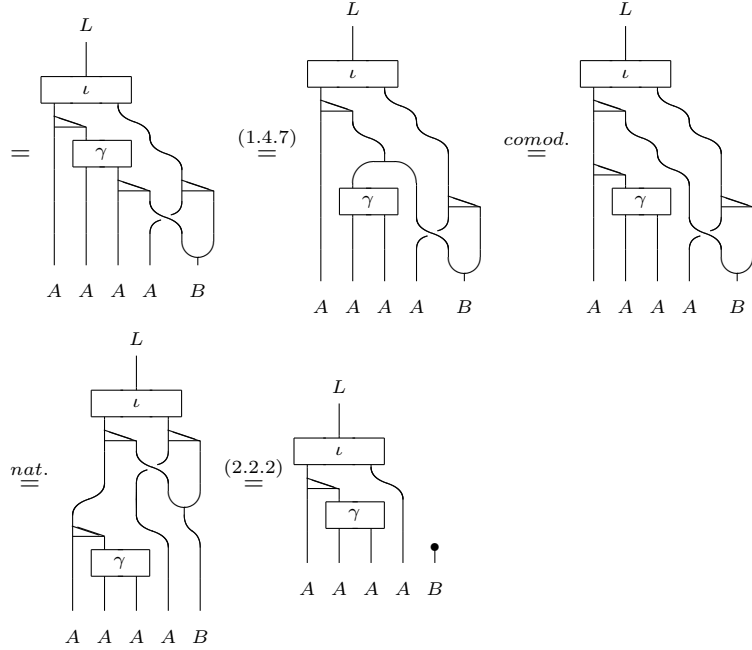

$$\begin{aligned} &= (A \otimes A \otimes A \otimes A \otimes \eta_B) \circ G \\ &= (A \otimes A \otimes A \otimes A \otimes \eta_B) \circ (\iota \otimes A \otimes A) \circ G' \\ &= (\iota \otimes A \otimes A \otimes H) \circ ((A \otimes A)^{coB} \otimes (A \otimes A \otimes \eta_B)) \circ G' \end{aligned}$$

Moreover, we see that Δ satisfies and even is determined by

$$\begin{aligned}
 & (\iota \otimes \iota) \circ \Delta \\
 &= (\iota \otimes A \otimes A) \circ ((A \otimes A)^{coB} \otimes \iota) \circ \Delta \\
 &= (\iota \otimes A \otimes A) \circ G' \\
 &= G
 \end{aligned}$$

or graphically

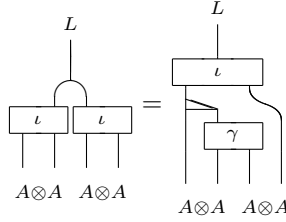
(2.2.3)

Finally, by showing that this morphism Δ satisfies equation (2.2.1), we obtain $\Delta_L = \Delta$, which gives a description for the comultiplication of L . Again, using the fact that A is flat, we know that $\iota \otimes \iota \otimes A$ is a monomorphism. Hence, it's enough to show

$$(\iota \otimes \iota \otimes A) \circ (\Delta \otimes A) \circ \chi_L^- = (\iota \otimes \iota \otimes A) \circ (L \otimes \chi_L^-) \circ \chi_L^-$$

First observe

$$\begin{aligned}
 & (\iota \otimes A) \circ \chi_L^- \\
 &= (\iota \otimes A) \circ \beta_- \circ (A \otimes \eta_A) \\
 &= \beta \circ (A \otimes \eta_A) \\
 &= (A \otimes \nabla_A \otimes A) \circ (A \otimes A \otimes \gamma) \circ \chi_{A \otimes A}^+ \circ (A \otimes \eta_A) \\
 &= \begin{array}{c} A \\ | \\ \text{---} \\ | \\ \gamma \\ | \\ A \quad A \quad A \end{array} \stackrel{(1.4.3)}{=} \begin{array}{c} A \\ | \\ \text{---} \\ | \\ \gamma \\ | \\ A \quad A \quad A \end{array} \stackrel{nat.}{=} \begin{array}{c} A \\ | \\ \text{---} \\ | \\ \gamma \\ | \\ A \quad A \quad A \end{array} = \begin{array}{c} A \\ | \\ \text{---} \\ | \\ \gamma \\ | \\ A \quad A \quad A \end{array} \\
 &= (A \otimes \gamma) \circ \chi_A^+
 \end{aligned}$$

which makes it easier to compute

$$\begin{aligned}
 &= (\iota \otimes \iota \otimes A) \circ (\Delta \otimes A) \circ \chi_L^- \\
 &= (G \otimes A) \circ \chi_L^- \\
 &= (A \otimes \gamma \otimes A \otimes A) \circ (\chi_A^+ \otimes A \otimes A) \circ (\iota \otimes A) \circ \chi_L^- \\
 &= (A \otimes \gamma \otimes A \otimes A) \circ (\chi_A^+ \otimes A \otimes A) \circ (A \otimes \gamma) \circ \chi_A^+ \\
 &= (A \otimes \gamma \otimes A \otimes A) \circ (A \otimes B \otimes \gamma) \circ (\chi_A^+ \otimes B) \circ \chi_A^+ \\
 &= (A \otimes \gamma \otimes \gamma) \circ (A \otimes \Delta_B) \circ \chi_A^+
 \end{aligned}$$

while also

$$\begin{aligned}
 &(\iota \otimes \iota \otimes A) \circ (L \otimes \chi_L^-) \circ \chi_L^- \\
 &= (A \otimes A \otimes \iota \otimes A) \circ (\iota \otimes A) \circ (L \otimes \chi_L^-) \circ \chi_L^- \\
 &= (A \otimes A \otimes \iota \otimes A) \circ (A \otimes A \otimes \chi_L^-) \circ (\iota \otimes A) \circ \chi_L^- \\
 &= (A \otimes A \otimes A \otimes \gamma) \circ (A \otimes A \otimes \chi_A^+) \circ (A \otimes \gamma) \circ \chi_A^+
 \end{aligned}$$

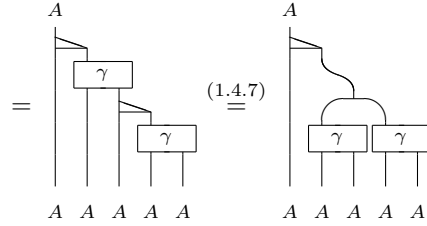

proving that Δ satisfies (2.2.1).

Using this description for Δ_L , we can now prove the following universal property of L .

Proposition 2.2.5. *Let B be any bialgebra in \mathcal{C} and $\chi : A \rightarrow B \otimes A$ a left B -comodule structure making A a B - H -bi-Galois object, then there is a unique isomorphism of $f : L \rightarrow B$ of bialgebras such that $\chi = (f \otimes A) \circ \chi_L$ (where χ_L is the L -comodule structure on A).*

Proof. By [73, Proposition 4.4] we already have the uniqueness and existence of an algebra map $f : L \rightarrow B$. Moreover, it is shown that f is determined by

(2.2.4)

It remains to show that under our circumstances, this f is a coalgebra map, i.e.,

$$\begin{array}{c} L \\ \begin{array}{|c|} \hline f \\ \hline \end{array} \begin{array}{|c|} \hline f \\ \hline \end{array} \\ \hline B \quad B \end{array} = \begin{array}{c} L \\ \begin{array}{|c|} \hline f \\ \hline \end{array} \\ \hline B \quad B \end{array}$$

Observe that

The diagram illustrates the proof that f is a coalgebra map. It consists of several stages of string diagrams connected by equality symbols (\equiv):

- Top row:** Shows the naturality condition nat. and equation (2.2.4). The first diagram has two f boxes on B strands and an A strand. The second diagram has f boxes on B strands and an A strand with a dot. The third diagram has χ boxes on B strands and an A strand.
- Middle row:** Shows equation (2.2.3) and the comodule condition comod. . The first diagram has l and χ boxes. The second diagram has l , χ , and γ boxes. The third diagram has l , χ , and γ boxes with a dot on the A strand.
- Bottom row:** Shows the naturality/unit condition nat. unit and equation (2.2.4). The first diagram has l and χ boxes. The second diagram has l , χ , and γ boxes. The final diagram shows f on B strands and a dot on the A strand.

which shows that f is comultiplicative. □

Consider the group $Aut_{Hopf}(\mathcal{C}; B)$ of Hopf algebra automorphisms of B in \mathcal{C} .

Definition 2.2.6. A Hopf algebra automorphism $\alpha \in Aut_{Hopf}(\mathcal{C}; B)$ is said to be *coinner* if there exists an algebra map $\vartheta : B \rightarrow I$ in \mathcal{C} such that $\alpha = ad(\vartheta) = \vartheta^{-1} * id * \vartheta$, where $\vartheta^{-1} = \vartheta \circ S$ (an algebra map is always convolution invertible), or graphically

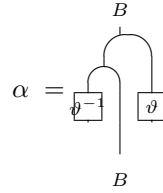

The set of coinner automorphisms of B in \mathcal{C} is denoted $CoInn(\mathcal{C}; B)$.

It is straight forward to verify that $CoInn(\mathcal{C}; B)$ is a normal subgroup of $Aut_{Hopf}(\mathcal{C}; B)$. Indeed, given $\alpha = ad(\vartheta) \in CoInn(\mathcal{C}; B)$ and $\beta \in Aut_{Hopf}(\mathcal{C}; B)$, one can check that $\beta \circ \alpha \circ \beta^{-1} = ad(\vartheta \circ \beta^{-1})$.

Definition 2.2.7. The group of co-outer automorphisms of the Hopf algebra B in \mathcal{C} is denoted and defined by

$$CoOut(\mathcal{C}; B) = Aut_{Hopf}(\mathcal{C}; B) / CoInn(\mathcal{C}; B)$$

The following lemma is a generalization of [68, Lemma 3.11] to the braided setting.

Lemma 2.2.8. *Let L, B be braided Hopf algebras in the category \mathcal{C} such that the set $BiGal(\mathcal{C}; L, B)$ is nonempty. Then $CoOut(\mathcal{C}; L)$ acts freely on $BiGal(\mathcal{C}; L, B)$. Moreover, the orbit of an isomorphism class $[A]$ is given by those classes in $BiGal(\mathcal{C}; L, B)$ represented by a bi-Galois extension C such that $A \cong C$ as right B -Galois extensions of I .*

Proof. It is clear that $Aut_{Hopf}(\mathcal{C}; L)$ acts on $BiGal(\mathcal{C}; L, B)$ via

$$\alpha \curvearrowright A = {}^\alpha A$$

where ${}^\alpha A$ is the L - B -bi-Galois object with new left L -comodule structure given by ${}^\alpha \chi^- = (\alpha \otimes A) \circ \chi^-$.

In order to have a well defined action of $CoOut(\mathcal{C}; L)$ on $BiGal(\mathcal{C}; L, B)$, we need to prove that any coinner automorphism of L acts as the identity on $BiGal(\mathcal{C}; L, B)$. Take $\alpha \in CoInn(\mathcal{C}; L)$, i.e., assume there exists an algebra morphism $\vartheta : L \rightarrow I$ such that $\alpha = ad(\vartheta) = \vartheta^{-1} * id * \vartheta$. Let $A \in BiGal(\mathcal{C}; L, B)$. Define the morphism $g : {}^\alpha A \rightarrow A$ by

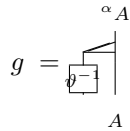

g is obviously right B -colinear. g is also left L -colinear:

The following computation shows that g is also an algebra morphism.

Therefore, ${}^\alpha A \cong A$ as bi-Galois extensions.

To prove that $CoOut(\mathcal{C}; L)$ acts freely on $BiGal(\mathcal{C}; L, B)$, assume we have $\alpha \in Aut_{Hopf}(\mathcal{C}; L)$ and $A \in BiGal(\mathcal{C}; L, B)$ such that there is an isomorphism $g : {}^\alpha A \rightarrow A$. In particular, g can be seen as an algebra map $A \rightarrow A$ and

(2.2.5)

By Proposition 2.2.4, there is a unique algebra morphism $\vartheta : L \rightarrow I$ such that $g = (\vartheta \otimes A) \circ \chi_L^-$. We claim that $\alpha = ad(\vartheta^{-1})$. By faithfully flatness of A , it suffices to show $\alpha \otimes A = ad(\vartheta^{-1}) \otimes A : L \otimes A \rightarrow L \otimes A$. On the other hand, as both g and $can_- : A \otimes A \rightarrow L \otimes A$ are bijective, it suffices to show $(\alpha \otimes g) \circ can_- = (ad(\vartheta^{-1}) \otimes g) \circ can_- : A \otimes A \rightarrow L \otimes A$. We verify

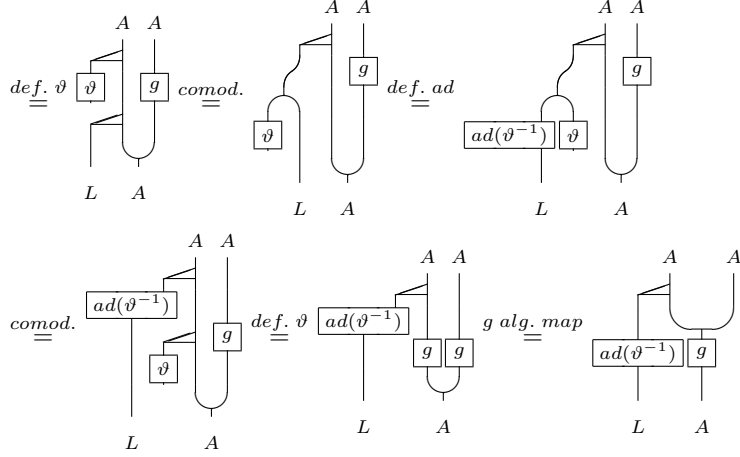

Lastly, assume $f : A \rightarrow C$ is an isomorphism of right B -Galois extensions. We can use f to define a new L -comodule structure on A , as follows

$$\chi' = (A \xrightarrow{f} C \xrightarrow{\chi_C^-} L \otimes C \xrightarrow{L \otimes f^{-1}} L \otimes A)$$

It is straightforward to check that this turns (A, χ', χ_A^+) again into an L - B -bi-Galois object, now being isomorphic to C (via f) as L - B -bi-Galois extensions. On the other hand, by the Proposition 2.2.5, there exists a Hopf automorphism of L , say α , such that $\chi' = (\alpha \otimes A) \circ \chi_A^-$, or $(A, \chi', \chi_A^+) = \alpha A$. Thus, $C \cong \alpha A$ as L - B -bi-Galois extensions. Hence we obtain the orbit statement. \square

Remark 2.2.9. Of course, for $\alpha \in \text{Aut}_{\text{Hopf}}(\mathcal{C}; B)$ and $A \in \text{BiGal}(\mathcal{C}; L, B)$, one can similarly define an L - B -bi-Galois object A^α where now the right B -comodule structure is altered by α . In particular, one can look at B^α and it is not difficult to verify that B^α is isomorphic to $\alpha^{-1}B$ via α .

Corollary 2.2.10. *Lemma 2.2.8 induces an injective group homomorphism*

$$\begin{aligned} i : \text{CoOut}(\mathcal{C}; B) &\longrightarrow \text{BiGal}(\mathcal{C}; B) \\ [\alpha] &\longmapsto [\alpha B] \end{aligned}$$

Proof. By the preceding lemma, it remains to show that this map is a group morphism, or $\alpha^{\circ\omega} B \cong \alpha B \square_B^\omega B$. We immediately see

$$\begin{aligned} \alpha B \square_B^\omega B &\cong \alpha^{\circ\omega} B^\omega \square_B^\omega B && \text{by Remark 2.2.9} \\ &\cong \alpha^{\circ\omega} B \square_B B \\ &\cong \alpha^{\circ\omega} B \end{aligned}$$

\square

2.3 Bi-Galois objects over a cocommutative Hopf algebra

In the previous section, we have already considered the group of braided B -bi-Galois objects. If the Hopf algebra B is moreover cocommutative, one can look at those bi-Galois objects whose left B -comodule structure is obtained from the right B -comodule structure using the braiding. I.e., under suitable conditions (on the braiding), one can equip the set $Gal_r(\mathcal{C}; B)$ of right B -Galois objects with a group structure, making it a subgroup of $BiGal(\mathcal{C}; B)$. In this section we will prove that if B is a cocommutative Hopf algebra in \mathcal{C} , the group $BiGal(\mathcal{C}; B)$ can be computed in terms of $Aut_{Hopf}(\mathcal{C}; B)$ and $Gal_r(\mathcal{C}; B)$.

Definition 2.3.1. A braided Hopf algebra B in \mathcal{C} is said to be *cocommutative* if

$$\begin{array}{c} B \\ \circlearrowleft \\ B \quad B \end{array} = \begin{array}{c} B \\ \circlearrowright \\ B \quad B \end{array}$$

Throughout this section B is assumed to be a flat cocommutative Hopf algebra in \mathcal{C} . If (A, χ^+) is a right comodule, we can define a left B -comodule structure on A via

$$\chi^- = \begin{array}{c} A \\ \circlearrowleft \\ B \quad A \end{array} \quad (2.3.1)$$

However, to turn a right B -comodule algebra (A, χ^+) into a left B -comodule algebra, we need to assume that $\phi_{B,A} = \phi_{A,B}^{-1}$ for any right B -Galois object A . Moreover, with this new left B -comodule algebra structure, the left canonical morphism $can_- : A \otimes A \rightarrow B \otimes A$ is of the following form

$$can_- = \begin{array}{c} A \quad A \\ \diagdown \quad \diagup \\ B \quad A \end{array} \stackrel{(2.3.1)}{=} \begin{array}{c} A \quad A \\ \circlearrowleft \\ B \quad A \end{array} \stackrel{nat.}{=} \begin{array}{c} A \quad A \\ \circlearrowright \\ B \quad A \end{array} = \phi_{B,A}^{-1} \circ \overline{can}_+ \quad (2.3.2)$$

where $\overline{can}_+ : A \otimes A \rightarrow A \otimes B$ is the morphism

$$\overline{can}_+ = \begin{array}{c} A \quad A \\ \diagdown \quad \diagup \\ A \quad B \end{array}$$

Lemma 2.3.2. *Let A be a right B -Galois object in \mathcal{C} . can_+ is an isomorphism if and only if $\overline{\text{can}}_+$ is an isomorphism.*

Proof. Consider the morphism $\alpha : A \otimes B \rightarrow A \otimes B$ defined by

$$\alpha = \begin{array}{c} A \quad B \\ \text{---} \text{---} \\ \text{---} \text{---} \\ \text{---} \text{---} \\ A \quad B \end{array}$$

Then α is an isomorphism with inverse given by

$$\alpha^{-1} = \begin{array}{c} A \quad B \\ \text{---} \text{---} \\ \text{---} \text{---} \\ \text{---} \text{---} \\ A \quad B \end{array}$$

Indeed

$$\alpha^{-1} \circ \alpha = \begin{array}{c} A \quad B \\ \text{---} \text{---} \\ \text{---} \text{---} \\ \text{---} \text{---} \\ A \quad B \end{array} = \begin{array}{c} A \quad B \\ \text{---} \text{---} \\ \text{---} \text{---} \\ \text{---} \text{---} \\ A \quad B \end{array} = \begin{array}{c} A \quad B \\ \text{---} \text{---} \\ \text{---} \text{---} \\ \text{---} \text{---} \\ A \quad B \end{array} = \begin{array}{c} A \quad B \\ \text{---} \text{---} \\ \text{---} \text{---} \\ \text{---} \text{---} \\ A \quad B \end{array} = \begin{array}{c} A \quad B \\ \text{---} \text{---} \\ \text{---} \text{---} \\ \text{---} \text{---} \\ A \quad B \end{array}$$

since

$$\begin{array}{c} B \\ \text{---} \\ \text{---} \\ \text{---} \\ B \end{array} = \begin{array}{c} B \\ \text{---} \\ \text{---} \\ \text{---} \\ B \end{array} = \begin{array}{c} B \\ \bullet \\ \bullet \\ B \end{array}$$

Similarly, one can show $\alpha \circ \alpha^{-1} = \text{id}_{A \otimes B}$.

Moreover

$$\begin{aligned}
 & \alpha \circ \text{can}_+ \\
 &= \text{[Diagram 1]} \stackrel{(1.4.3)}{=} \text{[Diagram 2]} \stackrel{\text{comod. asso.}}{=} \text{[Diagram 3]} \stackrel{(1.2.3)}{=} \text{[Diagram 4]} \\
 &= \overline{\text{can}_+}
 \end{aligned}$$

establishing the claim in the lemma. □

Combining equation (2.3.2) and Lemma 2.3.2, we obtain that can_- is an isomorphism if can_+ is an isomorphism. I.e., if (A, χ^+) is a right B -Galois object, then $(A, \phi_{A,B}^{-1} \circ \chi^+, \chi^+)$ is a B -bi-Galois object. The same was proved in [39], be it in a different manner. Furthermore, in the same reference the following was shown:

Theorem 2.3.3 ([39, Section 3.4 & Theorem 3.5.1]). *Let B be a flat and cocommutative Hopf algebra in a braided monoidal category \mathcal{C} and suppose that the following assumption is fulfilled:*

$$\begin{array}{c}
 A \quad A' \\
 \frown \quad \quad \quad \frown \\
 A \quad A' \quad \quad \quad A \quad A'
 \end{array}
 =
 \begin{array}{c}
 A \quad A' \\
 \frown \quad \quad \quad \frown \\
 A \quad A' \quad \quad \quad A \quad A'
 \end{array}$$

for any two right B -Galois objects A and A' , then the set $\text{Gal}_r(\mathcal{C}; B)$ of isomorphism classes of faithfully flat right B -Galois objects forms a group. In particular, if A is a right B -Galois object, then so is \overline{A} , with right B -comodule structure given by

$$\chi_A^+ = \begin{array}{c} A \\ | \\ \oplus \\ | \\ A \quad B \end{array}$$

The product of two classes $[A]$ and $[A']$ is given by the class of the cotensor product $A \square_B A'$, where A' is endowed with a left B -comodule structure as in (2.3.1). The unit is given by $[H]$.

Moreover, $\text{Gal}_r(\mathcal{C}; B)$ is an abelian subgroup of $\text{BiGal}(\mathcal{C}; B)$ (where any right B -Galois object becomes a B -bi-Galois object as described above).

Obviously, as B is cocommutative, we have $CoInn(\mathcal{C}; B) = 1$. Indeed assume $\alpha \in CoInn(\mathcal{C}; B)$, i.e. $\exists \vartheta : B \rightarrow I$ in \mathcal{C} such that $\alpha = ad(\vartheta) = \vartheta^{-1} * id * \vartheta$, then

$$\alpha = \text{[Diagram 1]} \stackrel{\text{cocomm.}}{=} \text{[Diagram 2]} \stackrel{\text{nat. coasso.}}{=} \text{[Diagram 3]} = \text{[Diagram 4]}$$

whence $CoOut(\mathcal{C}; B) = Aut_{Hopf}(\mathcal{C}; B)$.

Let $\alpha \in Aut_{Hopf}(\mathcal{C}; B)$ and $A \in Gal_r(\mathcal{C}; B)$ and recall the definition of A^α from Remark 2.2.9 (which makes sense for a right B -Galois object too). That is, $\chi_{A^\alpha}^+ = (A \otimes \alpha) \circ \chi_A^+$. Defining $A \leftarrow \alpha = A^{\alpha^{-1}}$ we obtain a right action from $Aut_{Hopf}(\mathcal{C}; B)$ on $Gal_r(\mathcal{C}; B)$. We can consider the semi-direct product group $Aut_{Hopf}(\mathcal{C}; B) \ltimes Gal_r(\mathcal{C}; B)$. We will show that this group is isomorphic to the group of B -bi-Galois objects.

Remark 2.3.4. Let $\alpha \in Aut_{Hopf}(\mathcal{C}; B)$ and $A \in Gal_r(\mathcal{C}; B)$ and consider $A \leftarrow \alpha = A^{\alpha^{-1}} \in Gal_r(\mathcal{C}; B)$. Considering $A \leftarrow \alpha$ as a braided B -bi-Galois object, its induced left B -comodule structure equals

$$\chi_{A \leftarrow \alpha}^- = \text{[Diagram 1]} = \text{[Diagram 2]} \stackrel{\text{nat.}}{=} \text{[Diagram 3]} = (\alpha^{-1} \otimes A) \circ \chi_A^- \quad (2.3.3)$$

It is to say, as an induced B -bi-Galois object, $A \leftarrow \alpha$ corresponds to $\alpha^{-1} A \alpha^{-1}$.

Proposition 2.3.5. *Let B be a flat cocommutative Hopf algebra in the braided monoidal category \mathcal{C} . Furthermore assume $\phi_{A, A'} = \phi_{A', A}^{-1}$ for any two right B -Galois objects A and A' . We have a group isomorphism*

$$\begin{aligned} \Psi : Aut_{Hopf}(\mathcal{C}; B) \ltimes Gal_r(\mathcal{C}; B) &\longrightarrow BiGal(\mathcal{C}; B) \\ (\alpha, [A]) &\longmapsto [\alpha A] \end{aligned}$$

Proof. Here A is a B -bi-Galois object as in Theorem 2.3.3. By Lemma 2.2.8, we immediately obtain the bijectivity of Ψ . To prove that Ψ is a group morphism, we

use the observation in Remark 2.3.4:

$$\begin{aligned}
\Psi((\alpha, [A])(\beta, [C])) &= \Psi(\alpha \circ \beta, [(A \leftarrow \beta) \square_B C]) \\
&= [{}^{\alpha \circ \beta}((A \leftarrow \beta) \square_B C)] \\
&= [{}^{\alpha \circ \beta}(A \leftarrow \beta) \square_B C] \\
&= [{}^{\alpha \circ \beta}(\beta^{-1} A \beta^{-1}) \square_B C] && \text{by (2.3.3)} \\
&= [{}^{\alpha} A \beta^{-1} \square_B C] \\
&= [{}^{\alpha} A \square_B \beta C] \\
&= \Psi(\alpha, [A]) \Psi(\beta, [C])
\end{aligned}$$

for $\alpha, \beta \in \text{Aut}_{\text{Hopf}}(\mathcal{C}; B)$ and $A, C \in \text{Gal}_r(\mathcal{C}; B)$. \square

Proposition 2.3.5 generalizes [68, Lemma 4.7] to the case where B is a cocommutative Hopf algebra in a braided monoidal category.

2.4 Braided lazy cohomology

The theory of lazy cohomology for a k -Hopf algebra H is extensively described by Bichon and Carnovale in [8]. One can also introduce the concept of the second lazy cohomology group for a braided Hopf algebra B . We recollect the terminology and explain how the second lazy cohomology group can be viewed as a subgroup of the group of braided B -bi-Galois objects. Although this is not explicitly stated in [74], all the necessary ingredients for this particular claim can be found there. Accordingly, we consider the following statements up to Corollary 2.4.1 as known and will list them without providing proof.

Recall the definition of (braided) lazy two-cocycles. B still denotes an arbitrary Hopf algebra in a (strict) braided monoidal category $(\mathcal{C}, I, \otimes, \phi)$. A *left cocycle* is a convolution invertible morphism $\sigma : B \otimes B \rightarrow I$ such that

Similarly we can define *right cocycles*. By $\text{Reg}^1(\mathcal{C}; B)$ we denote the set of normalized ($\gamma \circ \eta_B = id_I$) and convolution invertible morphisms $\gamma : B \rightarrow I$. Similarly, $\text{Reg}^2(\mathcal{C}; B)$ denotes the set of convolution invertible morphisms $\sigma : B \otimes B \rightarrow I$ satisfying $\sigma \circ (\eta_B \otimes B) = \sigma \circ (B \otimes \eta_B) = \epsilon_B$ (σ is said to be normalized). $\text{Reg}^1(\mathcal{C}; B)$ and $\text{Reg}^2(\mathcal{C}; B)$ are groups under the convolution product. We shall denote the set of left

2-cocycles by $Z^2(\mathcal{C}; B)$.

An element $\sigma : B \otimes B \rightarrow I$ of $Reg^2(\mathcal{C}; B)$ is called *lazy* if σ commutes (under the convolution product) with the multiplication of B . I.e., if

$$\sigma * \nabla = \begin{array}{c} B \quad B \\ \text{---} \quad \text{---} \\ \text{---} \quad \text{---} \\ \text{---} \quad \text{---} \\ \sigma \\ \text{---} \\ B \end{array} = \begin{array}{c} B \quad B \\ \text{---} \quad \text{---} \\ \text{---} \quad \text{---} \\ \text{---} \quad \text{---} \\ \sigma \\ \text{---} \\ B \end{array} = \nabla * \sigma \quad (2.4.2)$$

The subgroup of lazy elements of $Reg^2(\mathcal{C}; B)$ is denoted by $Reg_L^2(\mathcal{C}; B)$ and the set of lazy 2-cocycles by $Z_L^2(\mathcal{C}; B)$. Obviously, $Z_L^2(\mathcal{C}; B) = Reg_L^2(\mathcal{C}; B) \cap Z^2(\mathcal{C}; B)$. The set of 2-cocycles $Z^2(\mathcal{C}; B)$ need not be closed under convolution. This problem however disappears when working with lazy 2-cocycles. Moreover, if σ is a lazy left 2-cocycle, then σ is a right 2-cocyle as well and σ^{-1} is a left 2-cocyle. $Z_L^2(\mathcal{C}; B)$ is a subgroup of $Reg_L^2(\mathcal{C}; B)$.

Furthermore, one has that σ is a lazy 2-cocycle if and only if B is equal to Doi's twist Hopf algebra ${}_{\sigma}B_{\sigma^{-1}}$, hence the terminology. Here ${}_{\sigma}B_{\sigma^{-1}}$ has the same coalgebra structure as B and multiplication given by

$$\sigma \nabla_{\sigma^{-1}} = \begin{array}{c} B \quad B \\ \text{---} \quad \text{---} \\ \text{---} \quad \text{---} \\ \text{---} \quad \text{---} \\ \sigma \quad \sigma^{-1} \\ \text{---} \\ B \end{array}$$

An element $\gamma \in Reg^1(\mathcal{C}; B)$ is called *lazy* if

$$\begin{array}{c} B \\ \text{---} \\ \gamma \\ \text{---} \\ B \end{array} = \begin{array}{c} B \\ \text{---} \\ \gamma \\ \text{---} \\ B \end{array}$$

i.e. $\gamma * id_F = id_F * \gamma$. The subset of lazy elements in $Reg^1(\mathcal{C}; B)$, denoted $Reg_L^1(\mathcal{C}; B)$, is a central subgroup of $Reg^1(\mathcal{C}; B)$. It is easy to see that γ is lazy if and only if $ad(\gamma) : B \rightarrow B$, given by $ad(\gamma) = \gamma^{-1} * id_B * \gamma$, is trivial.

Consider the map $\delta : Reg^1(\mathcal{C}; B) \rightarrow Reg^2(\mathcal{C}; B)$ given by $\delta(\gamma) = (\gamma \otimes \gamma) * (\gamma^{-1} \circ \nabla)$ for $\gamma \in Reg^1(\mathcal{C}; B)$. δ induces a group morphism $Reg_L^1(\mathcal{C}; B) \rightarrow Z_L^2(\mathcal{C}; B)$ with image, say $B_L^2(\mathcal{C}; B)$, contained in the center of $Z_L^2(\mathcal{C}; B)$. Elements in $B_L^2(\mathcal{C}; B)$ are called lazy 2-coboundaries. The *second lazy cohomology group* is defined as

$$H_L^2(\mathcal{C}; B) = Z_L^2(\mathcal{C}; B)/B_L^2(\mathcal{C}; B).$$

Given $\sigma : B \otimes B \rightarrow I$, we can define a new product on B , by

$$\sigma \nabla = \sigma * \nabla = \begin{array}{c} \begin{array}{cc} B & B \\ \uparrow & \uparrow \\ \text{---} & \text{---} \\ \downarrow & \downarrow \\ \sigma & \\ \downarrow & \downarrow \\ B & \end{array} \end{array}$$

for $x, y \in F$. Then $\sigma \nabla$ is an associative product with unit if and only if σ is a normalized 2-cocycle. Denote by ${}_\sigma B$ the right B -comodule algebra where ${}_\sigma B = B$ as a right comodule and with product given by $\sigma \nabla$, then ${}_\sigma B$ is a right B -Galois object with the normal basis property (${}_\sigma B$ is isomorphic to B as a right B -comodule), or equivalently, ${}_\sigma B$ is cleft (there exists a convolution invertible right B -comodule morphism $j : B \rightarrow {}_\sigma B$). Similarly, given a right normalized 2-cocycle σ , we can construct a left B -Galois object B_σ .

Finally, for a lazy 2-cocycle σ , consider $B(\sigma)$, which equals B as a bicomodule (so it is endowed with Δ_B as left and right B -comodule structure) and with algebra structure given by

$$\sigma \nabla = \sigma * \nabla = \nabla * \sigma$$

We have that $B(\sigma)$ is a B -bi-Galois object. In this way, we can identify $H_L^2(\mathcal{C}; B)$ with a normal subgroup of $BiGal(\mathcal{C}; B)$.

Corollary 2.4.1. *There is an injective group homomorphism*

$$j : H_L^2(\mathcal{C}; B) \longrightarrow BiGal(\mathcal{C}; B) \\ [\sigma] \longmapsto [B(\sigma)]$$

We will now construct a group exact sequence, combining the groups $CoOut(\mathcal{C}; B)$, $H_L^2(\mathcal{C}; B)$ and $BiGal(\mathcal{C}; B)$. We need to introduce some more groups first.

Let $ad(\gamma) : B \rightarrow B$ be the automorphism defined as before: $ad(\gamma) = \gamma^{-1} * id_B * \gamma$. To be more precise, $ad : Reg^1(\mathcal{C}; B) \rightarrow Aut_{coalg}(\mathcal{C}; B)$ is a group morphism with kernel $Reg_L^1(\mathcal{C}; B)$. It is known that $\delta(Reg_L^1(\mathcal{C}; B)) \subset Z_L^2(\mathcal{C}; B)$. However, it can occur that $\gamma \in Reg^1(\mathcal{C}; B) \setminus Reg_L^1(\mathcal{C}; B)$ while also $\delta(\gamma) \in Z_L^2(\mathcal{C}; B)$. It is possible to describe when exactly this happens.

Lemma 2.4.2. *Let $\gamma \in Reg^1(\mathcal{C}; B)$. Then $ad(\gamma)$ is a Hopf algebra automorphism if and only if the coboundary $\delta(\gamma) \in Reg_L^2(\mathcal{C}; B)$.*

Proof. The proof is straightforward (but tedious). □

A Hopf automorphism is said to be *cointernal* if it is of the form $ad(\gamma)$ for some $\gamma \in Reg^1(\mathcal{C}; B)$. This allows us to introduce the set $CoInt(\mathcal{C}; B)$ of cointernal

automorphisms. Let $\alpha \in \text{Aut}_{\text{Hopf}}(\mathcal{C}; B)$ and $\gamma \in \text{Reg}^1(\mathcal{C}; B)$, then $\alpha \circ \text{ad}(\gamma) \circ \alpha^{-1} = \text{ad}(\gamma \circ \alpha^{-1})$, hence $\text{CoInt}(\mathcal{C}; B)$ forms a normal subgroup of $\text{Aut}_{\text{Hopf}}(\mathcal{C}; B)$. Moreover, $\text{CoInn}(\mathcal{C}; B)$ is contained in $\text{CoInt}(\mathcal{C}; B)$.

Define the set

$$\begin{aligned} \text{Reg}_{aL}^1(\mathcal{C}; B) &= \{\gamma \in \text{Reg}^1(\mathcal{C}; B) \mid \delta(\gamma) \in \text{Reg}_L^2(\mathcal{C}; B)\} \\ &= \{\gamma \in \text{Reg}^1(\mathcal{C}; B) \mid \text{ad}(\gamma) \in \text{CoInt}(\mathcal{C}; B)\} \\ &= \text{ad}^{-1}(\text{Aut}_{\text{Hopf}}(\mathcal{C}; B)) \end{aligned}$$

which is a subgroup of $\text{Reg}^1(\mathcal{C}; B)$. Elements in $\text{Reg}_{aL}^1(\mathcal{C}; B)$ are called *almost lazy*.

Lemma 2.4.3. *Let $\gamma \in \text{Reg}^1(\mathcal{C}; B)$ and $\mu \in \text{Reg}_{aL}^1(\mathcal{C}; B)$, i.e., $\delta(\mu) \in \text{Reg}_L^2(\mathcal{C}; B)$. Then*

$$\delta(\gamma * \mu) = \delta(\gamma) * \delta(\mu).$$

Proof.

$$\begin{aligned} &\delta(\gamma) * \delta(\mu) \\ &= (\gamma \otimes \gamma) * (\gamma^{-1} \circ \nabla) * \delta(\mu) \\ &= (\gamma \otimes \gamma) * \delta(\mu) * (\gamma^{-1} \circ \nabla) && (\delta(\mu) \in \text{Reg}_L^2(\mathcal{C}; B)) \\ &= (\gamma \otimes \gamma) * (\mu \otimes \mu) * (\mu^{-1} \circ \nabla) * (\gamma^{-1} \circ \nabla) \\ &= (\gamma * \mu \otimes \gamma * \mu) * ((\gamma^{-1} \otimes \mu^{-1}) \circ \nabla) \\ &= \delta(\gamma * \mu) \end{aligned}$$

□

Consequently, δ induces a group morphism $\text{Reg}_{aL}^1(\mathcal{C}; B) \rightarrow Z_L^2(\mathcal{C}; B)$, which we again denote by δ . Its kernel is easily seen to equal $\text{Alg}(\mathcal{C}; B, I)$.

Define

$$\begin{aligned} \text{CoOut}^-(\mathcal{C}; B) &= \text{Reg}_{aL}^1(\mathcal{C}; B) / \text{ad}^{-1}(\text{CoInn}(\mathcal{C}; B)) \\ &\cong \text{CoInt}(\mathcal{C}; B) / \text{CoInn}(\mathcal{C}; B) \end{aligned}$$

which can be viewed as a subgroup of $\text{CoOut}(\mathcal{C}; B)$.

It appears that $\text{CoOut}(\mathcal{C}; B)$ acts (from the right) on $H_L^2(\mathcal{C}; B)$ as follows.

Lemma 2.4.4. *Let $\alpha \in \text{Aut}_{\text{Hopf}}(\mathcal{C}; B)$ and $\sigma \in \text{Reg}^2(\mathcal{C}; B)$. Define an action*

$$\sigma \leftarrow \alpha = \sigma \circ (\alpha \otimes \alpha)$$

from $\text{Aut}_{\text{Hopf}}(\mathcal{C}; B)$ on $\text{Reg}^2(\mathcal{C}; B)$. This induces a well-defined right action (by automorphisms) of $\text{CoOut}(\mathcal{C}; B)$ on $H_L^2(\mathcal{C}; B)$

$$[\sigma] \leftarrow [\alpha] = [\sigma \leftarrow \alpha]$$

Sketch of proof. Let $\sigma \in \text{Reg}^2(\mathcal{C}; B)$ and $\alpha \in \text{Aut}_{\text{Hopf}}(\mathcal{C}; B)$, the following statements can be verified directly:

- $\sigma \leftarrow \alpha \in \text{Reg}^2(\mathcal{C}; B)$ since $(\sigma \leftarrow \alpha)^{-1} = \sigma^{-1} \leftarrow \alpha$,
- if $\beta \in \text{Aut}_{\text{Hopf}}(\mathcal{C}; B)$, then $\sigma \leftarrow (\alpha \circ \beta) = (\sigma \leftarrow \alpha) \leftarrow \beta$,
- if moreover $\sigma \in \text{Reg}_L^2(\mathcal{C}; B)$ then also $\sigma \leftarrow \alpha \in \text{Reg}_L^2(\mathcal{C}; B)$,
- if σ is a left cocycle, then so is $\sigma \leftarrow \alpha$,
- let $\omega \in \text{Reg}^2(\mathcal{C}; B)$, then $(\sigma * \omega) \leftarrow \alpha = (\sigma \leftarrow \alpha) * (\omega \leftarrow \alpha)$,
- if $\mu \in \text{Reg}_L^1(\mathcal{C}; B)$, then $\mu \circ \alpha \in \text{Reg}_L^1(\mathcal{C}; B)$,
- if $\mu \in \text{Reg}^1(\mathcal{C}; B)$, then $\delta(\mu) \leftarrow \alpha = \delta(\mu \circ \alpha)$,
- if $\alpha \in \text{CoInn}(\mathcal{C}; B)$ and $\sigma \in \text{Reg}_L^2(\mathcal{C}; B)$, then $\sigma \leftarrow \alpha = \sigma$.

Combining these statements, we obtain the claim in the lemma. \square

Lemma 2.4.4 allows us to consider the semi-direct product $\text{CoOut}(\mathcal{C}; B) \ltimes H_L^2(\mathcal{C}; B)$ where

$$([\alpha], [\sigma])([\beta], [\tau]) = ([\alpha \circ \beta], [(\sigma \leftarrow \beta) * \tau])$$

We can now present the main theorem of this section, which is a generalization of [8, Theorem 3.13].

Theorem 2.4.5. *Let B be a Hopf algebra in a braided monoidal category \mathcal{C} and assume \mathcal{C} has equalizers. Then there is a group exact sequence*

$$1 \longrightarrow \text{CoOut}^-(\mathcal{C}; B) \xrightarrow{\iota_B} \text{CoOut}(\mathcal{C}; B) \ltimes H_L^2(\mathcal{C}; B) \xrightarrow{\Upsilon_B} \text{BiGal}(\mathcal{C}; B)$$

Proof.

- Consider the map

$$\begin{aligned} I : \text{Reg}_{aL}^1(\mathcal{C}; B) &\longrightarrow \text{CoOut}(\mathcal{C}; B) \ltimes H_L^2(\mathcal{C}; B) \\ \gamma &\longmapsto ([ad(\gamma)], [\delta(\gamma^{-1})]) \end{aligned}$$

We know that $ad(\gamma * \mu) = ad(\gamma) \circ ad(\mu)$ for $\gamma, \mu \in \text{Reg}_{aL}^1(\mathcal{C}; B)$, so in order to show that I is a group morphism, it suffices to show $(\delta(\gamma^{-1}) \leftarrow ad(\mu)) * \delta(\mu^{-1}) = \delta((\gamma * \mu)^{-1})$. Now

$$\begin{aligned} &(\delta(\gamma^{-1}) \leftarrow ad(\mu)) * \delta(\mu^{-1}) \\ &= \delta(\gamma^{-1} \circ ad(\mu)) * \delta(\mu^{-1}) \\ &= \delta((\gamma^{-1} \circ ad(\mu)) * \mu^{-1}) \\ &= \delta(\mu^{-1} * \gamma^{-1}) = \delta((\gamma * \mu)^{-1}) \end{aligned}$$

Moreover, say $\gamma \in Ker I$, then $ad(\gamma) \in CoInn(\mathcal{C}; B)$. Conversely, take $\gamma \in ad^{-1}(CoInn(B))$. Then there exists an algebra morphism $\mu : B \rightarrow I$ such that $ad(\gamma) = ad(\mu)$, or $ad(\gamma^{-1} * \mu) = id_B$ implying $\gamma^{-1} * \mu \in Reg_L^1(\mathcal{C}; B)$. Since also $\delta(\gamma^{-1} * \mu) = \delta(\gamma^{-1})$ (as μ is an algebra morphism), we obtain $\delta(\gamma^{-1}) \in B_L^2(\mathcal{C}; B)$, whence $\gamma \in Ker I$. We have shown $Ker I = ad^{-1}(CoInn(B))$. Consequently, I induces an injective group morphism

$$\begin{aligned} \iota_B : CoOut^-(\mathcal{C}; B) &\longrightarrow CoOut(\mathcal{C}; B) \times H_L^2(\mathcal{C}; B) \\ [\gamma] &\longmapsto ([ad(\gamma)], [\delta(\gamma^{-1})]) \end{aligned}$$

- Let $\alpha \in Aut_{Hopf}(\mathcal{C}; B)$ and $\sigma \in Z_L^2(\mathcal{C}; B)$. Then $\alpha \dashv j(\sigma) = {}^\alpha B(\sigma)$ is a B -bi-Galois object in \mathcal{C} . Moreover, if $\alpha \in CoInn(\mathcal{C}; B)$ and $\sigma \in B_L^2(\mathcal{C}; B)$, then ${}^\alpha B(\sigma) = B(\sigma)$ by Lemma 2.2.8 while $B(\sigma) = B$ by Corollary 2.4.1. Hence

$$\begin{aligned} \Upsilon_B : CoOut(\mathcal{C}; B) \times H_L^2(\mathcal{C}; B) &\longrightarrow BiGal(\mathcal{C}; B) \\ ([\alpha], [\sigma]) &\longmapsto [{}^\alpha B(\sigma)] \end{aligned}$$

is a well-defined morphism.

Let $\alpha, \beta \in Aut_{Hopf}(\mathcal{C}; B)$ and $\sigma, \tau \in Z_L^2(\mathcal{C}; B)$. To show that Υ_B is a group morphism, consider $g : B \rightarrow B \otimes B$, $g = (\beta \otimes B) \circ \Delta_B$. Since

g induces a morphism $\hat{g} : {}^{\alpha\beta} B((\sigma \leftarrow \beta) * \tau) \rightarrow {}^\alpha B(\sigma) \square_B {}^\beta B(\tau)$. A straightforward verification shows that \hat{g} is a bilinear algebra morphism of Galois objects, hence an isomorphism.

- Let $([\alpha], [\sigma]) \in Ker \Upsilon_B$, i.e., there exists a B -bilinear algebra morphism $f : {}^\alpha B(\sigma) \rightarrow B$. As f is right B -colinear, we get

Say $\mu = \varepsilon \circ f : B \rightarrow I$. As f is left B -colinear too, i.e.,

we see

or $\alpha = \mu * id * \mu^{-1} = ad(\mu^{-1})$. Finally, we have

since f is an algebra map. Using this, we see

So $\alpha = ad(\mu^{-1})$ where $\mu^{-1} \in Reg_{aL}^1(\mathcal{C}; B)$. Hence $Ker \Upsilon_B \subset \iota_B(CoOut^-(\mathcal{C}; B))$. On the other hand, take $\mu \in Reg_{aL}^1(\mathcal{C}; B)$, then $\Upsilon_B \circ$

$\iota_B([\mu]) = [{}^{ad(\mu)}B(\delta(\mu^{-1}))]$. Define

$$f = \begin{array}{c} B \\ \text{---} \mu^{-1} \text{---} \\ \text{---} \end{array}$$

Then $f : {}^{ad(\mu)}B(\delta(\mu^{-1})) \rightarrow B$ is a bilinear algebra (iso)morphism. Indeed, it is not difficult to verify the bilinearity, while the following computation shows it is an algebra map:

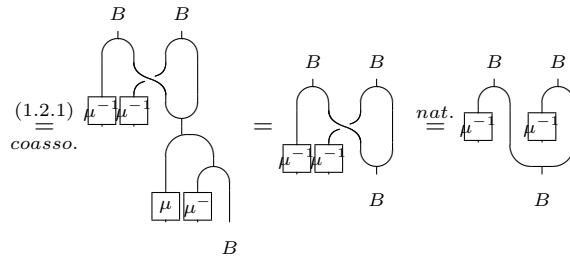
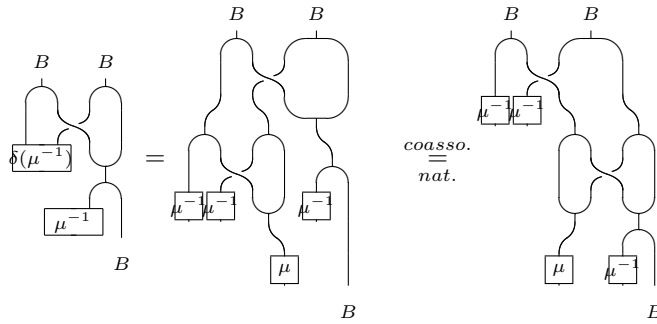

Ergo, $\Upsilon_B \circ \iota_B = 1$. This finishes the proof.

□

In Section 3.6 we will present an application of this theorem.

2.5 Bi-Galois objects versus monoidal equivalences

In this section, we will further investigate the relation between monoidal equivalences and braided bi-Galois objects. We are inspired by the following result due to Schauenburg.

Proposition 2.5.1 ([68, Corollary 5.7]). *Let k be a commutative ring and let B and L be k -flat Hopf algebras. The following are equivalent:*

1. ${}^B\mathcal{M}$ and ${}^L\mathcal{M}$ are equivalent as monoidal k -linear categories (B and L are then said to be monoidally co-Morita equivalent),
2. there is faithfully flat L - B -bi-Galois extension of k .

As before, let (\mathcal{C}, ϕ) be a braided (strict) monoidal category with equalizers. Suppose B and L are flat Hopf algebras in \mathcal{C} . The if statement of the aforementioned proposition has been generalized to the braided setting by Schauenburg [73, 74]. I.e., if A is a faithfully flat L - B -bi-Galois object, then the cotensor functor $\alpha_A = A \square_B - : {}^B\mathcal{C} \rightarrow {}^L\mathcal{C}$ is a monoidal equivalence. In particular, for two B -comodules M and N , there's an isomorphism

$$\xi : (A \square_B M) \otimes (A \square_B N) \rightarrow A \square_B (M \otimes N)$$

which is induced by $\xi_0 = (\nabla_A \otimes M \otimes N) \circ (A \otimes \phi_{A,M} \otimes N) \circ (\iota \otimes \iota)$. Graphically, ξ satisfies

Further observations can be made about the functor $A \square_B -$, but first we need to introduce some terminology.

Definition 2.5.2 ([26]). Let \mathcal{C} and \mathcal{D} be monoidal categories and suppose \mathcal{E} is a monoidal subcategory of both \mathcal{C} and \mathcal{D} . A monoidal equivalence $\alpha : \mathcal{C} \rightarrow \mathcal{D}$ is said to be *trivializable on \mathcal{E}* if the restriction $\alpha|_{\mathcal{E}}$ is isomorphic to $id_{\mathcal{E}}$ as monoidal functors. We will denote by $Aut(\mathcal{C})$ respectively $Aut(\mathcal{C}, \mathcal{E})$ the group of isomorphism classes of monoidal autoequivalences of \mathcal{C} , respectively monoidal autoequivalences of \mathcal{C} trivializable on \mathcal{E} . If \mathcal{C} and \mathcal{E} are braided, we denote by $Aut^{br}(\mathcal{C}, \mathcal{E})$ the group of isomorphism classes of braided monoidal autoequivalences of \mathcal{C} trivializable on \mathcal{D} .

Following [61] we recall the definition of module categories.

Definition 2.5.3. Let \mathcal{C} be a monoidal category. A *left module category over \mathcal{C}* is a category \mathcal{M} equipped with

- a bifunctor $* : \mathcal{C} \times \mathcal{M} \rightarrow \mathcal{M}$, $(X, M) \mapsto X * M$,
- natural associativity isomorphisms $m_{X,Y,M} : (X \otimes Y) * M \rightarrow X * (Y * M)$,
- unit isomorphisms $l_M : I * M \rightarrow M$ such that

$$\begin{array}{ccc}
 ((X \otimes Y) \otimes Z) * M & \xrightarrow{a_{X,Y,Z} * M} & (X \otimes (Y \otimes Z)) * M \\
 \downarrow m_{X \otimes Y, Z, M} & & \downarrow m_{X, Y \otimes Z, M} \\
 (X \otimes Y) * (Z * M) & \xrightarrow{m_{X, Y, Z * M}} & X * ((Y \otimes Z) * M) \\
 & & \downarrow X * m_{Y, Z, M} \\
 (X \otimes Y) * (Z * M) & \xrightarrow{m_{X, Y, Z * M}} & X * (Y * (Z * M)) \\
 & & \downarrow m_{X, I, M} \\
 (X \otimes I) * M & \xrightarrow{m_{X, I, M}} & X * (I * M) \\
 \swarrow r_X * M & & \searrow X * l_M \\
 & & X * M
 \end{array}$$

are commutative diagrams for $X, Y, Z \in \mathcal{C}$ and $M \in \mathcal{M}$.

Equivalently, \mathcal{M} is left module category over \mathcal{C} if there is given a monoidal functor $\mathcal{C} \rightarrow \text{End}(\mathcal{M})$, where $\text{End}(\mathcal{M})$ is the monoidal category of endofunctors of \mathcal{M} (product is given by composition of functors).

Right \mathcal{C} -module categories can be defined similarly. Let \mathcal{D} be another monoidal category. \mathcal{M} is said to be a $(\mathcal{C}, \mathcal{D})$ -bimodule category if \mathcal{M} is simultaneously a left \mathcal{C} -module category and right \mathcal{D} -module category, together with natural isomorphisms $\gamma_{X, M, Y} : (X * M) * Y \rightarrow X * (M * Y)$ satisfying certain compatibility axioms, cf. [40, Proposition 2.12].

A \mathcal{C} -module functor between left \mathcal{C} -module categories \mathcal{M} and \mathcal{N} is a pair (F, θ) , where $F : \mathcal{M} \rightarrow \mathcal{N}$ is a functor and $\theta : F(- * -) \rightarrow - * F(-)$ is a natural isomorphism such that the following diagrams commute

$$\begin{array}{ccc}
 F((X \otimes Y) * M) & \xrightarrow{F(m_{X, Y, M})} & F(X * (Y * M)) \\
 \downarrow \theta_{X \otimes Y, M} & & \downarrow \theta_{X, Y * M} \\
 (X \otimes Y) * F(M) & \xrightarrow{m_{X, Y, F(M)}} & X * F(Y * M) \\
 & & \downarrow X * \theta_{Y, M} \\
 (X \otimes Y) * F(M) & \xrightarrow{m_{X, Y, F(M)}} & X * (Y * F(M))
 \end{array}$$

$$\begin{array}{ccc}
F(I * M) & \xrightarrow{F(l_M)} & X * F(M) \\
\searrow \theta_{I,M} & & \nearrow l_{F(M)} \\
& & I * F(M)
\end{array}$$

for $X, Y \in \mathcal{C}$ and $M \in \mathcal{M}$.

The category ${}^B\mathcal{C}$ is naturally a right C -module category. Indeed, if $M \in {}^B\mathcal{C}$ and $X \in \mathcal{C}$, we can define $M * X = M \otimes X$, which is the tensor product in \mathcal{C} with left B -coaction given by $\chi_M^- \otimes X$.

Any object $X \in \mathcal{C}$ can be seen as an object in ${}^B\mathcal{C}$ if we equip X with the trivial left B -comodule structure $\eta_B \otimes X$. We will denote this comodule by X^t , although sometimes we will just write X if the situation will make clear that $X \in \mathcal{C}$ is equipped with the trivial comodule structure.

Lemma 2.5.4. *Let B and L be flat Hopf algebras in \mathcal{C} and suppose $\alpha : {}^B\mathcal{C} \rightarrow {}^L\mathcal{C}$ is a (strong) monoidal functor. Then α is trivializable on \mathcal{C} if and only if α is a right \mathcal{C} -module functor.*

Proof. Suppose α is a right \mathcal{C} -module functor. The unit object $I \in \mathcal{C}$ can also be seen as an object in ${}^B\mathcal{C}$ (with trivial B -comodule structure). Then

$$\alpha(X) \cong \alpha(I \otimes X^t) \xrightarrow{\theta_{I,X}} \alpha(I) \otimes X \cong I \otimes X \cong X$$

for any $X \in \mathcal{C}$. Conversely, suppose α is trivializable on \mathcal{C} , then

$$\alpha(M \otimes X) \xrightarrow{\varphi_{M,X}^{-1}} \alpha(M) \otimes \alpha(X) \cong \alpha(M) \otimes X$$

for $M \in {}^B\mathcal{C}$ and $X \in \mathcal{C}$. □

Lemma 2.5.5. *Let B and L be flat Hopf algebras in \mathcal{C} . Suppose A is a faithfully flat L - B -bi-Galois object. The monoidal equivalence functor $A \square_B - : {}^B\mathcal{C} \rightarrow {}^L\mathcal{C}$ is trivializable on \mathcal{C} , or equivalently, α is a right \mathcal{C} -module functor.*

Proof. For any $M \in {}^B\mathcal{C}$ we have

$$\begin{array}{ccccc}
 1 & \longrightarrow & A \otimes (A \square_B M) & \longrightarrow & A \otimes (A \otimes M) & \rightrightarrows & A \otimes (A \otimes B \otimes M) \\
 & & \downarrow \sim & & \downarrow = & & \downarrow = \\
 1 & \longrightarrow & (A \otimes A) \square_B M & \longrightarrow & (A \otimes A) \otimes M & \rightrightarrows & (A \otimes A) \otimes B \otimes M \\
 & & \downarrow \sim & & \downarrow \text{can}_+ \otimes M & & \downarrow = \\
 1 & \longrightarrow & (A \otimes B) \square_B M & \longrightarrow & (A \otimes B) \otimes M & \rightrightarrows & (A \otimes B) \otimes B \otimes M \\
 & & \downarrow \sim & & \downarrow = & & \downarrow = \\
 1 & \longrightarrow & A \otimes (B \square_B M) & \longrightarrow & A \otimes (B \otimes M) & \rightrightarrows & A \otimes (B \otimes B \otimes M) \\
 & & \downarrow \sim & & & & \\
 & & A \otimes M & & & &
 \end{array}$$

The first and fourth sequence are exact because A is flat. The associativity constraints are identities, as \mathcal{C} is assumed to be strict. Hence $A \otimes M \cong A \otimes (A \square_B M)$, where the isomorphism $A \otimes M \rightarrow A \otimes (A \square_B M)$ is induced by the morphism

$$\begin{array}{c}
 \begin{array}{c}
 A \quad M \\
 \begin{array}{c}
 \diagup \quad \diagdown \\
 \boxed{\gamma} \\
 \diagdown \quad \diagup \\
 A \quad A \quad M
 \end{array}
 \end{array}
 \end{array} \tag{2.5.1}$$

Now let $X \in \mathcal{C}$ and consider X^t . The morphism $\eta_A \otimes X : X \rightarrow A \otimes X$ induces a morphism, say $f : X \rightarrow A \square_B X$. Moreover if X has trivial B -comodule structure (2.5.1) becomes

$$\begin{array}{c}
 \begin{array}{c}
 A \quad X^t \\
 \begin{array}{c}
 \diagup \quad \diagdown \\
 \boxed{\gamma} \\
 \diagdown \quad \diagup \\
 A \quad A \quad X^t
 \end{array}
 \end{array}
 =
 \begin{array}{c}
 \begin{array}{c}
 A \quad X^t \\
 \begin{array}{c}
 \bullet \\
 \diagdown \quad \diagup \\
 \boxed{\gamma} \\
 \diagdown \quad \diagup \\
 A \quad A \quad X^t
 \end{array}
 \end{array}
 \stackrel{(1.4.10)}{=}
 \begin{array}{c}
 \begin{array}{c}
 A \quad X^t \\
 \begin{array}{c}
 \bullet \\
 \diagdown \quad \diagup \\
 \bullet \\
 A \quad A \quad X^t
 \end{array}
 \end{array}
 =
 \begin{array}{c}
 \begin{array}{c}
 A \quad X^t \\
 \begin{array}{c}
 \bullet \\
 \bullet \\
 A \quad A \quad X^t
 \end{array}
 \end{array}
 \end{array}$$

Hence the isomorphism $A \otimes X \cong A \otimes (A \square_B X)$ coincides with $A \otimes f$. By faithfully flatness of A , f must be an isomorphism in \mathcal{C} . Thus $X \cong A \square_B X$ (as \mathcal{C} -objects). \square

Consider $\alpha_A = A \square_B -$ as in the previous lemma. Let $\mathcal{U} : {}^L\mathcal{C} \rightarrow \mathcal{C}$ be the forgetful functor and define $\omega_A = \mathcal{U} \circ \alpha_A : {}^L\mathcal{C} \rightarrow \mathcal{C}$. Thus if $M \in {}^B\mathcal{C}$, then $\alpha_A(M) = \omega_A(M)$ as \mathcal{C} -objects, so if we want to emphasize the fact that we treat $\alpha_A(M)$ as a \mathcal{C} -object, we can (but not always will) use $\omega_A(M)$.

The tensor product of two B -comodules in \mathcal{C} is again a B -comodule through the diagonal coaction (1.4.1). In particular, if $X^t \in \mathcal{C}$ and $M \in {}^B\mathcal{C}$ arbitrary, then $X^t \otimes M \in {}^B\mathcal{C}$, then

$$\chi_{X^t \otimes M}^- = \begin{array}{c} X^t \quad M \\ \text{---} \\ \text{---} \\ \text{---} \\ B \quad X^t \quad M \end{array}$$

By naturality

$$\begin{array}{c} X^t \quad M \\ \text{---} \\ \text{---} \\ \text{---} \\ B \quad X^t \quad M \end{array} = \begin{array}{c} X^t \quad M \\ \text{---} \\ \text{---} \\ \text{---} \\ B \quad X^t \quad M \end{array} \quad (2.5.2)$$

which is saying that the braiding $\phi_{X^t, M} : X^t \otimes M \rightarrow M \otimes X^t$ is a morphism in ${}^B\mathcal{C}$. We can now make the following observation.

Lemma 2.5.6. *With notation as above, we have*

$$\begin{array}{ccc} \omega_A(X^t) \otimes \omega_A(M) & \xrightarrow{\varphi_{X, M}} & \omega_A(X^t \otimes M) \\ \downarrow \phi_{\omega_A(X^t), \omega_A(M)} & & \downarrow \omega_A(\phi_{X^t, M}) \\ \omega_A(M) \otimes \omega_A(X^t) & \xrightarrow{\varphi_{M, X}} & \omega_A(M \otimes X^t) \end{array} \quad (\text{A})$$

for $M \in {}^B\mathcal{C}$ and $X \in \mathcal{C}$.

Proof. Let $f : X^t \rightarrow A \square_B X^t$ be the isomorphism in \mathcal{C} induced by $\eta_A \otimes X$ as in Lemma 2.5.5. The morphism $\omega_A(\phi_{M, X^t}) \circ \varphi_{X, M} \circ (f \otimes (A \square_B M)) : X^t \otimes (A \square_B M) \rightarrow A \square_B (M \otimes X^t)$ is induced by

$$(A \otimes \phi_{M, X^t}) \circ \xi_0 \circ (\eta_A \otimes X) = \begin{array}{c} X \quad A \quad M \\ \text{---} \\ \text{---} \\ \text{---} \\ A \quad M \quad X \end{array}$$

while the morphism $\varphi_{M,X} \circ \phi_{\omega_A(X^t), \omega_A(M)} \circ (f \otimes (A \square_B M))$ is induced by

$$\xi_0 \circ \phi_{A \otimes X^t, A \otimes M} \circ (\eta_A \otimes X) = \begin{array}{c} X \quad A \quad M \\ \begin{array}{c} \bullet \\ \begin{array}{c} \text{---} \text{---} \text{---} \\ \text{---} \text{---} \text{---} \\ \text{---} \text{---} \text{---} \\ \text{---} \text{---} \text{---} \\ \text{---} \text{---} \text{---} \\ \text{---} \text{---} \text{---} \end{array} \\ A \quad M \quad X \end{array} \end{array}$$

As both diagrams are equal by naturality and since $f \otimes (A \square_B M)$ is an isomorphism, we obtain $\omega_A(\phi_{X^t, M}) \circ \varphi_{X, M} = \varphi_{M, X} \circ \phi_{\omega_A(X^t), \omega_A(M)}$. \square

Thus a faithfully flat braided L - B -bi-Galois object A induces a monoidal (right \mathcal{C} -linear) equivalence $A \square_B - : {}^B\mathcal{C} \rightarrow {}^L\mathcal{C}$ which is trivializable on \mathcal{C} and satisfies (A). Our next goal is to investigate whether the converse statement is valid. That is, suppose $\alpha : {}^B\mathcal{C} \rightarrow {}^L\mathcal{C}$ is a monoidal equivalence trivializable on \mathcal{C} and satisfying (A), does α come from a faithfully flat bi-Galois object? By Lemma 2.5.4, α is a right \mathcal{C} -module functor with

$$\theta_{M, X} = (\alpha(M \otimes X) \xrightarrow{\varphi_{M, X}^{-1}} \alpha(M) \otimes \alpha(X) \cong \alpha(M) \otimes X) \quad (2.5.3)$$

for $M \in {}^B\mathcal{C}$ and $X \in \mathcal{C}$.

Our approach is inspired by [77], in which the author assigns to a fibre functor $\omega : {}^H\mathcal{M} \rightarrow {}_k\mathcal{M}$, the right H -Galois object $\omega(H)$ (here H is a k -Hopf algebra). Let us similarly denote $\omega = \mathcal{U} \circ \alpha : {}^B\mathcal{C} \rightarrow \mathcal{C}$, where $\mathcal{U} : {}^L\mathcal{C} \rightarrow \mathcal{C}$ is the forgetful functor. We can use ω if we want to emphasize that we're working on the level of \mathcal{C} -objects. For example, we can say that $\alpha(B)$ is an algebra (in ${}^L\mathcal{C}$), or equivalently, $\omega(B)$ is an L -comodule algebra in \mathcal{C} .

Suppose M is an algebra in ${}^B\mathcal{C}$. It is known that a monoidal functor sends algebras to algebras. Hence, $\alpha(M) \in {}^L\mathcal{C}$ is an algebra, or equivalently, $\omega(M)$ is a left L -comodule algebra in \mathcal{C} . As an algebra in \mathcal{C} , $\omega(M)$ has multiplication map

$$\nabla_{\omega(M)} = (\omega(M) \otimes \omega(M) \xrightarrow{\varphi_{M, M}} \omega(M \otimes M) \xrightarrow{\omega(\nabla_M)} \omega(M)) \quad (2.5.4)$$

and unit

$$I \cong \omega(I) \xrightarrow{\omega(\eta_M)} \omega(M)$$

Suppose F is another (flat) Hopf algebra in \mathcal{C} . Let M be a B - F -bicomodule. By the bicomodule property, the comodule structure χ_M^+ can be seen as a left B -colinear morphism $M \rightarrow M \otimes F^t$. We can now define a right F -comodule structure on $\omega(M)$ as follows

$$\omega(M) \xrightarrow{\omega(\chi_M^+)} \omega(M \otimes F^t) \xrightarrow{\theta_{M, F^t}} \omega(M) \otimes F$$

We will now prove that if M is a B - F -bicomodule algebra, then $\omega(M)$ is a right F -comodule algebra, i.e.

$$\begin{array}{c} \omega(M) \quad \omega(M) \\ \text{---} \\ \text{---} \\ \text{---} \\ \omega(M) \quad F \end{array} = \begin{array}{c} \omega(M) \quad \omega(M) \\ \text{---} \\ \text{---} \\ \text{---} \\ \omega(M) \quad F \end{array}$$

that is, by definition of $\nabla_{\omega(M)}$ and $\chi_{\omega(M)}^+$, we want the outer diagram of the following diagram to commute

$$\begin{array}{ccccc} \omega(M) \otimes \omega(M) & \xrightarrow{\varphi_{M \otimes M}} & \omega(M \otimes M) & \xrightarrow{\omega(\nabla_M)} & \omega(M) \\ \downarrow \omega(\chi_M^+) \otimes \omega(\chi_M^+) & & \downarrow \omega(\chi_M^+ \otimes \chi_M^+) & & \downarrow \omega(\chi_M^+) \\ \omega(M \otimes F^t) \otimes \omega(M \otimes F^t) & \xrightarrow{\varphi_{M \otimes F^t, M \otimes F^t}} & \omega(M \otimes F^t \otimes M \otimes F^t) & & \omega(M \otimes F^t) \\ \downarrow \theta_{M, X} \otimes \theta_{M, X} & & \downarrow \omega(M \otimes \phi_{F^t, M} \otimes F) & & \downarrow \omega(\chi_M^+) \\ \omega(M) \otimes F \otimes \omega(M) \otimes F & & \omega(M \otimes M \otimes F^t \otimes F^t) & \xrightarrow{\omega(\nabla_M \otimes \nabla_F)} & \omega(M \otimes F^t) \\ \downarrow \omega(M) \otimes \phi_{F, \omega(M)} \otimes F & & \downarrow \theta_{M \otimes M, F \otimes F} & & \downarrow \theta_{M, F} \\ \omega(M) \otimes \omega(M) \otimes F \otimes F & \xrightarrow{\varphi_{M, M \otimes F \otimes F}} & \omega(M \otimes M) \otimes F \otimes F & \xrightarrow{\omega(\nabla_M) \otimes \nabla_F} & \omega(M) \otimes F \end{array} \quad (2.5.5)$$

Now (I) commutes by naturality of φ , (II) commutes since M is assumed to be a right F -comodule algebra in \mathcal{C} (see 1.4.3) and (III) commutes by naturality of θ . So it suffices to show the commutativity of diagram (IV). Taking the definition of $\theta_{M, X}$ as in (2.5.3) into consideration, we can divide (IV) into smaller diagrams as follows

$$\begin{array}{ccccccc}
 \omega(M \otimes F^t) & \xrightarrow{\varphi} & \omega(M \otimes F^t \otimes M \otimes F^t) & \xrightarrow{\omega(F \otimes \phi \otimes F)} & \omega(M \otimes M \otimes F^t \otimes F^t) & \xrightarrow{\varphi^{-1} \otimes \varphi^{-1}} & \omega(M \otimes M \otimes F^t \otimes F^t) \\
 \otimes \omega(M \otimes F^t) & & & & & & \\
 \downarrow \varphi^{-1} \otimes \varphi^{-1} & & \downarrow \varphi \circ id \otimes \varphi & & \downarrow id \otimes \omega(\phi) \otimes id & & \downarrow \varphi^{-1} \\
 \omega(M) \otimes \omega(F^t) & \xrightarrow{id \otimes \phi \otimes id} & \omega(M) \otimes \omega(F^t) \otimes \omega(M) \otimes \omega(F^t) & \xrightarrow{id \otimes \phi \otimes id} & \omega(M) \otimes \omega(F^t) \otimes \omega(M) \otimes \omega(F^t) & \xrightarrow{id \otimes \phi \otimes id} & \omega(M) \otimes \omega(F^t) \otimes \omega(M) \otimes \omega(F^t) \\
 \otimes \omega(M) \otimes \omega(F^t) & & \downarrow i \otimes \varphi \otimes \varphi \otimes p_i & & \downarrow id \otimes \varphi \otimes id & & \downarrow \varphi \otimes \varphi \\
 \omega(M) \otimes \omega(F^t) & \xrightarrow{id \otimes \phi \otimes id} & \omega(M) \otimes \omega(F^t) \otimes \omega(M) \otimes \omega(F^t) & \xrightarrow{id \otimes \phi \otimes id} & \omega(M) \otimes \omega(F^t) \otimes \omega(M) \otimes \omega(F^t) & \xrightarrow{id \otimes \phi \otimes id} & \omega(M) \otimes \omega(F^t) \otimes \omega(M) \otimes \omega(F^t) \\
 \otimes \omega(M) \otimes \omega(F^t) & & \downarrow id \otimes \varphi \otimes id & & \downarrow id \otimes \varphi \otimes id & & \downarrow id \otimes \varphi \\
 \omega(M) \otimes F & \xrightarrow{id \otimes \phi \otimes id} & \omega(M) \otimes F \otimes \omega(M) \otimes F & \xrightarrow{id \otimes \phi \otimes id} & \omega(M) \otimes F \otimes \omega(M) \otimes F & \xrightarrow{id \otimes \phi \otimes id} & \omega(M) \otimes F \otimes \omega(M) \otimes F \\
 \otimes \omega(M) \otimes F & & \downarrow \sim & & \downarrow \sim & & \downarrow \sim \\
 \omega(M) \otimes F & \xrightarrow{id \otimes \phi \otimes id} & \omega(M) \otimes F & \xrightarrow{id \otimes \phi \otimes id} & \omega(M) \otimes F & \xrightarrow{id \otimes \phi \otimes id} & \omega(M) \otimes F \\
 \otimes \omega(M) \otimes F & & & & & & \downarrow \varphi \otimes id \otimes id \\
 & & & & & & \omega(M \otimes M) \otimes F \otimes F
 \end{array}$$

(i) and (iii) commute since ω is monoidal while (ii) commutes since the braiding $\phi_{F^t, M} : F^t \otimes M \rightarrow M \otimes F^t$ is a morphism in ${}^B\mathcal{C}$ as observed in (2.5.2). Diagram (iv) commutes since we assume that the functor α is satisfying diagram (A). Finally, the bottom two diagrams commute by naturality. Thus, $\omega(M)$ is a right F -comodule algebra.

Proposition 2.5.7. *Let $\alpha : {}^B\mathcal{C} \rightarrow {}^L\mathcal{C}$ be a monoidal equivalence trivializable on \mathcal{C} and satisfying (A) and denote $\omega = \mathcal{U} \circ \alpha : {}^B\mathcal{C} \rightarrow \mathcal{C}$ as before. Let M be a B - F -bicomodule algebra, then $\omega(M)$ is an L - F -bicomodule algebra in \mathcal{C} .*

In particular, $\omega(B)$ is a flat L - B -bicomodule algebra in \mathcal{C} .

Proof. $\omega(M)$ is already shown to be a left L -comodule algebra and a right F -comodule algebra, it remains to prove that $\omega(M)$ is an L - F -bicomodule. By definition of $\chi_{\alpha(M)}^+$, we need to prove that the following diagram is commutative.

$$\begin{array}{ccccc}
\omega(M) & \xrightarrow{\omega(\chi_M^+)} & \omega(M \otimes F^t) & \xrightarrow{\theta_{M, F^t}} & \omega(M) \otimes F \\
\downarrow \chi_{\omega(M)}^- & & \downarrow \chi_{\omega(M \otimes F^t)}^- & & \downarrow \chi_{\omega(M)}^- \otimes F \\
L \otimes \omega(M) & \xrightarrow{L \otimes \omega(\chi_M^+)} & L \otimes \omega(M \otimes F^t) & \xrightarrow{L \otimes \theta_{M, F^t}} & L \otimes \omega(M) \otimes F
\end{array}
\quad \begin{array}{l} \text{(I)} \\ \text{(II)} \end{array}$$

As mentioned before, $\chi_M^+ : M \rightarrow M \otimes F^t$ is left B -colinear, thus $\omega(\chi_M^+) \in {}^L\mathcal{C}$. So diagram (I) commutes. Furthermore, diagram (II) commutes as θ_{M, F^t} is a morphism in ${}^L\mathcal{C}$.

Since B is naturally a B -bicomodule algebra via its comultiplication, $\omega(B)$ becomes an L - B -bicomodule algebra in \mathcal{C} . Finally, as α is an equivalence, it's immediate that $\omega(B)$ is a flat object in \mathcal{C} . \square

Let $M \in {}^B\mathcal{C}$. The comodule structure χ_M^- can be seen as a B -colinear morphism $M \rightarrow B \otimes M^t$. It is well-known that $M \cong B \square_B M$ as B -comodules in \mathcal{C} . Hence

$$1 \longrightarrow M \xrightarrow{\chi_M^-} B \otimes M^t \xrightarrow[\Delta_B \otimes M]{B \otimes \chi_M^-} B \otimes B^t \otimes M^t$$

is exact in ${}^B\mathcal{C}$. As α is exact (α being an equivalence), the sequence

$$1 \longrightarrow \alpha(M) \xrightarrow{\alpha(\chi_M^-)} \alpha(B \otimes M^t) \xrightarrow[\alpha(\Delta_B \otimes M)]{\alpha(B \otimes \chi_M^-)} \alpha(B \otimes B^t \otimes M^t)$$

is exact in ${}^L\mathcal{C}$. Since $\alpha(B)$ is an L - B -bicomodule and by definition of the cotensor product $\alpha(B) \square_B M$, the sequence

$$1 \longrightarrow \alpha(B) \square_B M \longrightarrow \alpha(B) \otimes M \xrightarrow[\chi_{\alpha(B)}^+ \otimes M]{\alpha(B) \otimes \chi_M^-} \alpha(B) \otimes B \otimes M$$

is also exact in ${}^L\mathcal{C}$. These two sequences in ${}^L\mathcal{C}$ can be linked by θ as follows

$$\begin{array}{ccccccc}
 1 & \longrightarrow & \alpha(M) & \xrightarrow{\alpha(\chi_M^-)} & \alpha(B \otimes M^t) & \xrightarrow[\alpha(\Delta_B \otimes M)]{\alpha(B \otimes \chi_M^-)} & \alpha(B \otimes B^t \otimes M^t) \\
 & & \downarrow \text{---} & & \downarrow \theta_{B,M} & & \downarrow \theta_{B,B \otimes M} \\
 1 & \longrightarrow & \alpha(B) \square_B M & \longrightarrow & \alpha(B) \otimes M & \xrightarrow[\chi_{\alpha(B)}^+ \otimes M]{\alpha(B) \otimes \chi_M^-} & \alpha(B) \otimes B \otimes M
 \end{array}$$

Indeed $\theta_{B,B \otimes M} \circ \alpha(B \otimes \chi_M^-) = (\alpha(B) \otimes \chi_M^-) \circ \theta_{B,M}$ by naturality of θ and

$$\begin{array}{ccc}
 \alpha(B \otimes M^t) & \xrightarrow{\alpha(\Delta_B \otimes M)} & \alpha(B \otimes B^t \otimes M^t) \\
 \downarrow \theta_{B,M} & & \downarrow \theta_{B \otimes B^t, M} \\
 \alpha(B) \otimes M & \xrightarrow{\alpha(\Delta_B) \otimes M} & \alpha(B \otimes B^t) \otimes M \\
 & \searrow \chi_{\alpha(B)}^+ \otimes M & \downarrow \theta_{B,B} \otimes M \\
 & & \alpha(B) \otimes B \otimes M
 \end{array}$$

commutes by naturality of θ and by definition of $\chi_{\alpha(B)}^+$. Hence

$$\alpha(M) \cong \alpha(B) \square_B M$$

is an isomorphism in ${}^L\mathcal{C}$, say G_M , for any B -comodule M in \mathcal{C} . The isomorphism $G : \alpha(-) \rightarrow \alpha(B) \square_B -$ is easily seen to be natural (since θ is).

Remark 2.5.8. For the sake of convenience, we will no longer make a distinction between $\alpha(M)$ and $\omega(M)$, as they are the same object in \mathcal{C} . If we say, for example, that $\alpha(M)$ is a right F -comodule algebra, it is to be understood that we mean that $\alpha(M) = \omega(M) \in \mathcal{C}$ is a right F -comodule algebra in \mathcal{C} .

Next we'll show that, if M is a B - F -bicomodule (algebra), then $\alpha(M) \cong \alpha(B) \square_B M$ is a left L -colinear and right F -colinear (algebra) isomorphism. To show that it is

right F -colinear, the following diagram should commute.

$$\begin{array}{ccc}
\alpha(M) & \xrightarrow{G_M} & \alpha(B)\square_B M \\
\alpha(\chi_M^+) \downarrow & (I) & \downarrow \alpha(B) \otimes \chi_M^+ \\
\alpha(M \otimes F^t) & \xrightarrow{G_{M \otimes F^t}} & \alpha(B)\square_B (M \otimes F^t) \\
\theta_{M,F} \downarrow & (II) & \downarrow \sim \\
\alpha(M) \otimes F & \xrightarrow{G_M \otimes F} & (\alpha(B)\square_B M) \otimes F
\end{array}$$

The top diagram commutes as the isomorphism G is natural. To show the commutativity of the bottom diagram, observe that

$$\begin{array}{ccccc}
1 & \longrightarrow & \alpha(M \otimes F^t) & \longrightarrow & \alpha(B \otimes M^t \otimes F^t) \rightrightarrows \alpha(B \otimes B \otimes M^t \otimes F^t) \\
& & \downarrow G_{M \otimes F^t} & & \downarrow \theta_{B, M \otimes F} & \downarrow \theta_{B, B \otimes M \otimes F} \\
1 & \longrightarrow & \alpha(B)\square_B (M \otimes F^t) & \longrightarrow & \alpha(B) \otimes M \otimes F^t \rightrightarrows \alpha(B) \otimes B \otimes M \otimes F^t \\
& & \downarrow \sim & & \downarrow = & \downarrow = \\
1 & \longrightarrow & (\alpha(B)\square_B M) \otimes F & \longrightarrow & \alpha(B) \otimes M \otimes F \rightrightarrows \alpha(B) \otimes B \otimes M \otimes F
\end{array}$$

where the last sequence is exact since F is flat, while

$$\begin{array}{ccccc}
1 & \longrightarrow & \alpha(M \otimes F^t) & \longrightarrow & \alpha(B \otimes M^t \otimes F^t) \rightrightarrows \alpha(B \otimes B \otimes M^t \otimes F^t) \\
& & \downarrow \theta_{M,F} & & \downarrow \theta_{B \otimes M^t, F} & \downarrow \theta_{B \otimes B^t \otimes M^t, F} \\
1 & \longrightarrow & \alpha(M) \otimes F & \longrightarrow & \alpha(B \otimes M^t) \otimes F \rightrightarrows \alpha(B \otimes B^t \otimes M^t) \otimes F \\
& & \downarrow G_M \otimes F & & \downarrow \theta_{B, M} \otimes F & \downarrow \theta_{B, B \otimes M} \otimes F \\
1 & \longrightarrow & (\alpha(B)\square_B M) \otimes F & \longrightarrow & \alpha(B) \otimes M \otimes F \rightrightarrows \alpha(B) \otimes B \otimes M
\end{array}$$

where we've again used the flatness of F . As $\theta_{B, M \otimes F} = (\theta_{B, M} \otimes F) \circ \theta_{B \otimes M^t, F}$ and $\theta_{B, B \otimes M \otimes F} = (\theta_{B, B \otimes M} \otimes F) \circ \theta_{B \otimes B^t \otimes M^t, F}$, we obtain the commutativity of (I). Thus $\alpha(B) \cong \alpha(B)\square_B M$ as L - F -bicomodules.

To show that G_M is an algebra morphism, we have to show $\nabla_{\alpha(B)\square_B M} \circ (G_M \otimes G_M) = G_M \circ \nabla_{\alpha(B)}$, or

$$\iota \circ \nabla_{\alpha(B)\square_B M} \circ (G_M \otimes G_M) = \iota \circ G_M \circ \nabla_{\alpha(B)}$$

by monicity of $\iota : \alpha(B)\square_B M \rightarrow \alpha(B) \otimes M$. Observe

$$\begin{aligned}
& \iota \circ G_M \circ \nabla_{\alpha(B)} \\
&= \theta_{B,M} \circ \alpha(\chi_M^-) \circ \alpha(\nabla_M) \circ \varphi_{M,M} && \text{by (2.5.4) and def. G} \\
&= \theta_{B,M} \circ \alpha(\nabla_B \otimes \nabla_M) \circ \alpha(B \otimes \phi_{M^t,B} \otimes M^t) \circ \alpha(\chi_M^- \otimes \chi_M^-) \circ \varphi_{M,M} && \text{by (1.4.2)} \\
&= \theta_{B,M} \circ \alpha(\nabla_B \otimes \nabla_M) \circ \alpha(B \otimes \phi_{M^t,B} \otimes M^t) \circ \varphi_{B \otimes M, B \otimes M} \circ (\alpha(\chi_M^-) \otimes \alpha(\chi_M^-))
\end{aligned}$$

where the last equality follows from the naturality of φ . On the other hand

$$\begin{aligned}
& \iota \circ \nabla_{\alpha(B)\square_B M} \circ (G_M \otimes G_M) \\
&= \nabla_{\alpha(B)\otimes M} \circ (\iota \otimes \iota) \circ (G_M \otimes G_M) \\
&= (\nabla_{\alpha(B)} \otimes \nabla_M) \circ (\alpha(B) \otimes \phi_{M,\alpha(B)} \otimes M) \circ (\theta_{B,M} \otimes \theta_{B,M}) \circ (\alpha(\chi_M^-) \otimes \alpha(\chi_M^-)) && \text{by def. G} \\
&= (\alpha(\nabla_B) \otimes \nabla_M) \circ (\varphi_{M,M} \otimes B \otimes B) \circ (\alpha(B) \otimes \phi_{M,\alpha(B)} \otimes M) \\
&\quad \circ (\theta_{B,M} \otimes \theta_{B,M}) \circ (\alpha(\chi_M^-) \otimes \alpha(\chi_M^-)) && \text{by (2.5.4)}
\end{aligned}$$

So we're done if we can show

$$\begin{aligned}
& \theta_{B,M} \circ \alpha(\nabla_B \otimes \nabla_M) \circ \alpha(B \otimes \phi_{M^t,B} \otimes M^t) \circ \varphi_{B \otimes M, B \otimes M} \\
&= (\alpha(\nabla_B) \otimes \nabla_M) \circ (\varphi_{M,M} \otimes B \otimes B) \circ (\alpha(B) \otimes \phi_{M,\alpha(B)} \otimes M) \circ (\theta_{B,M} \otimes \theta_{B,M})
\end{aligned}$$

which can be shown similar to proving that in (2.5.5) diagrams (III) and (IV) are commutative. We arrive at the following proposition.

Proposition 2.5.9. *Let $\alpha : {}^B\mathcal{C} \rightarrow {}^L\mathcal{C}$ be a monoidal equivalence trivializable on \mathcal{C} and satisfying (A). Let M be a B - F -bicomodule algebra, then*

$$\alpha(M) \cong \alpha(B)\square_B M$$

as L - F -bicomodule algebras in \mathcal{C} .

Now let $\beta : {}^L\mathcal{C} \rightarrow {}^B\mathcal{C}$ be an 'inverse' functor of the equivalence α . We could repeat the same process with β . I.e. $\beta(L)$ is a flat B - L -bicomodule algebra and

$$L \cong \alpha(\beta(L)) \cong \alpha(B)\square_B \beta(L)$$

as L -comodule algebras in \mathcal{C} . Similarly, we can show that

$$B \cong \beta(\alpha(B)) \cong \beta(L)\square_L \alpha(B)$$

as B -bicomodule algebras. The following proposition is due to Schauenburg.

Proposition 2.5.10 ([74, Proposition 3.4]). *Let L, B be flat Hopf algebras in \mathcal{C} , and A a flat L - B -bicomodule algebra. The following are equivalent:*

1. A is a faithfully flat L - B -bi-Galois object,
2. there is a flat B - L -bicomodule algebra A^{-1} such that $A \square_B A^{-1} \cong L$ as L -bicomodule algebras and $A^{-1} \square_L A \cong B$ as B -bicomodule algebras.

Ergo, we have proven the following theorem.

Theorem 2.5.11. *Assume $\alpha : {}^B\mathcal{C} \rightarrow {}^L\mathcal{C}$ is a monoidal equivalence trivialisable on \mathcal{C} satisfying (A), or equivalently, a right \mathcal{C} -module functor satisfying (A). Then $\alpha(B)$ is a faithfully flat L - B -bi-Galois object.*

The process of assigning an equivalence $\alpha_A = A \square_B -$ to an L - B -bi-Galois object A and the process of obtaining a bi-Galois object $\alpha(B)$ from an equivalence $\alpha : {}^B\mathcal{C} \rightarrow {}^L\mathcal{C}$ as described above, are obviously mutually inverse. Moreover, this correspondence is compatible with the multiplication of bi-Galois objects and the composition of functors. Indeed, let B, L, F be flat Hopf algebras in \mathcal{C} and suppose $\alpha : {}^B\mathcal{C} \rightarrow {}^L\mathcal{C}$ and $\alpha' : {}^L\mathcal{C} \rightarrow {}^F\mathcal{C}$ are monoidal equivalences, trivialisable on \mathcal{C} and satisfying (A). Then

$$\alpha'(\alpha(B)) = \alpha'(L) \square_L \alpha(B)$$

as F - B -bicomodule algebras, by Proposition 2.5.9. Hence, we have a group isomorphism between the group of faithfully flat B -bi-Galois objects and the group of isomorphism classes of autoequivalences of ${}^B\mathcal{C}$ trivialisable on \mathcal{C} and satisfying (A). Let's denote the latter by $\text{Aut}_{(A)}({}^B\mathcal{C}, \mathcal{C})$.

Proposition 2.5.12. *Let B be a flat Hopf algebra in \mathcal{C} , then*

$$\text{BiGal}(B) \cong \text{Aut}_{(A)}({}^B\mathcal{C}, \mathcal{C})$$

We will apply this proposition in Chapter 4.

Chapter 3

Extending bi-Galois objects and automorphisms to the Radford biproduct

In this chapter, k will be a field and H a Hopf algebra with bijective antipode. \mathcal{C} will be given by the braided monoidal category ${}^H_H\mathcal{YD}$, as in Example 1.1.5(2). Let B be a braided Hopf algebra in ${}^H_H\mathcal{YD}$. If no confusion is possible, we will often omit the specification of the category in the notation $BiGal(\mathcal{C}; B)$, shortly denoting $BiGal(B)$. Similar for $CoOut(B)$, $H_L^2(B)$, etcetera, relying on notation to make clear whether we are dealing with braided objects.

In the first section we will show that any braided B -bi-Galois object A can be 'extended' to a bi-Galois object over the Radford biproduct $B \rtimes H$. This process induces a group homomorphism $\xi : BiGal(\mathcal{C}; B) \rightarrow BiGal(B \rtimes H)$. This construction is motivated by [25, Theorem 4.4], in which the authors investigate the problem of extending (lazy) 2-cocycles from B to $B \rtimes H$ (under similar conditions as above). In particular, they have defined a morphism $\Gamma : H_L^2(\mathcal{C}; B) \rightarrow H_L^2(B \rtimes H)$. In Section 3.2 we will describe the image of ξ . Before we are able to give a description for the kernel, we need to construct a morphism $\zeta : CoOut(B) \rightarrow CoOut(B \rtimes H)$, which 'extends' co-outer automorphisms of B to co-outer automorphisms of the Radford biproduct. Next, in Section 3.5, we relate our morphism ξ to the morphism $H_L^2(\mathcal{C}; B) \rightarrow H_L^2(B \rtimes H)$ from [25], by using Corollary 2.4.1. We also give a short characterization of the image of the latter. By Theorem 2.4.5, there exists an exact sequence

$$1 \rightarrow CoOut^-(\mathcal{C}; B) \xrightarrow{\iota_B} CoOut(\mathcal{C}; B) \rtimes H_L^2(\mathcal{C}; B) \xrightarrow{\Upsilon_B} BiGal(\mathcal{C}; B).$$

By the same theorem, we obtain a similar exact sequence for the k -Hopf algebra $B \rtimes H$

$$1 \rightarrow \text{CoOut}^-(B \rtimes H) \xrightarrow{\iota_{B \rtimes H}} \text{CoOut}(B \rtimes H) \rtimes H_L^2(B \rtimes H) \xrightarrow{\Upsilon_{B \rtimes H}} \text{BiGal}(B \rtimes H).$$

In Section 3.6, we show the existence of a morphism from $\text{CoOut}^-(\mathcal{C}; B)$ to $\text{CoOut}^-(B \rtimes H)$. In other words, we now have a morphism from every group occurring in the first sequence to the corresponding group in the second sequence. The next step is to prove the commutativity of the resulting diagram. Using this diagram, we can give a new description of the kernel of Γ . Finally, we illustrate the results by considering Sweedler's Hopf algebra H_4 , which can be seen as a Radford biproduct $k[X]/(X^2) \rtimes kC_2$.

3.1 Extending bi-Galois objects

Assume A is a B -bi-Galois object in ${}^H_H\mathcal{YD}$. Let us, for the sake of completeness and to introduce the notation, clarify what this explicitly means.

- A is a Yetter-Drinfeld module. As before, denote the H -comodule structure by $\rho_A(a) = a_{(-1)} \otimes a_{(0)}$, then

$$\rho_A(h \cdot a) = h_1 a_{(-1)} S(h_3) \otimes h_2 \cdot a_{(0)} \quad (3.1.1)$$

- A is an algebra in ${}^H_H\mathcal{YD}$; A is an H -module algebra and H -comodule algebra, i.e.

$$h \cdot (ac) = (h_1 \cdot a)(h_2 \cdot c) \quad (3.1.2)$$

$$(ac)_{(-1)} \otimes (ac)_{(0)} = a_{(-1)} c_{(-1)} \otimes a_{(0)} c_{(0)} \quad (3.1.3)$$

for $a, c \in A$ and $h \in H$.

- A is a B -bicomodule in ${}^H_H\mathcal{YD}$; there exist a left and a right B -comodule structure on A . Let's introduce the following notation

$$\chi^- : A \rightarrow B \otimes A : a \mapsto a^{[-1]} \otimes a^{[0]}$$

$$\chi^+ : A \rightarrow A \otimes B : a \mapsto a^{[0]} \otimes a^{[1]}$$

Then

$$a^{[-1]} \otimes a^{[0][0]} \otimes a^{[0][1]} = a^{[0][-1]} \otimes a^{[0][0]} \otimes a^{[1]} \quad (3.1.4)$$

Moreover χ^- and χ^+ are H -linear

$$(h \cdot a)^{[-1]} \otimes (h \cdot a)^{[0]} = h_1 \cdot a^{[-1]} \otimes h_2 \cdot a^{[0]} \quad (3.1.5)$$

$$(h \cdot a)^{[0]} \otimes (h \cdot a)^{[1]} = h_1 \cdot a^{[0]} \otimes h_2 \cdot a^{[1]} \quad (3.1.6)$$

and H -colinear

$$\begin{aligned} a^{[-1]}_{(-1)} a^{[0]}_{(-1)} \otimes a^{[-1]}_{(0)} \otimes a^{[0]}_{(0)} \\ = a_{(-1)} \otimes a_{(0)}^{[-1]} \otimes a_{(0)}^{[0]} \end{aligned} \quad (3.1.7)$$

$$\begin{aligned} a^{[0]}_{(-1)} a^{[1]}_{(-1)} \otimes a^{[0]}_{(0)} \otimes a^{[1]}_{(0)} \\ = a_{(-1)} \otimes a_{(0)}^{[0]} \otimes a_{(0)}^{[1]} \end{aligned} \quad (3.1.8)$$

for $a \in A$ and $h \in H$.

- A is a B -bicomodule algebra in ${}^H_H\mathcal{YD}$; we have the following relations

left B -comodule algebra:

$$(ac)^{[-1]} \otimes (ac)^{[0]} = a^{[-1]}(a^{[0]}_{(-1)} \cdot c^{[-1]}) \otimes a^{[0]}_{(0)} c^{[0]} \quad (3.1.9)$$

right B -comodule algebra:

$$(ac)^{[0]} \otimes (ac)^{[1]} = a^{[0]}(a^{[1]}_{(-1)} \cdot c^{[0]}) \otimes a^{[1]}_{(0)} c^{[1]} \quad (3.1.10)$$

for $a, c \in A$.

- the left and right coinvariants are trivial, i.e. ${}^{coB}A \cong A^{coB} \cong k$.
- the left and right canonical morphisms

$$\begin{aligned} can_- : A \otimes A &\rightarrow B \otimes A : a \otimes c \mapsto a^{[-1]} \otimes a^{[0]}c \\ can_+ : A \otimes A &\rightarrow A \otimes B : a \otimes c \mapsto ac^{[0]} \otimes c^{[1]} \end{aligned}$$

are isomorphisms.

We recollect the construction of the *Radford biproduct* $B \rtimes H$ from [65]. $B \rtimes H$ is equal to $B \otimes H$ as a vector space, equipped with the so-called smash product and smash coproduct, defined as follows

$$\begin{aligned} (b \times h)(b' \times h') &= b(h_1 \cdot b') \times h_2 h' \\ \Delta(b \times h) &= (b_1 \times b_{2(-1)} h_1) \otimes (b_{2(0)} \otimes h_2) \end{aligned}$$

for $b, b' \in B$ and $h, h' \in H$. Remark that an element $b \otimes h$ is denoted by $b \times h$. The unit is given by $1_B \times 1_H$ whereas the counit is given by $\varepsilon_B \otimes \varepsilon_H$. Finally, $B \rtimes H$ is a Hopf algebra with antipode

$$S(b \times h) = (1 \times S_H(b_{(-1)} h))(S_B(b_{(0)}) \times 1)$$

for $b \in B$ and $h \in H$.

We will also need the following equation

$$b_{(-1)} \otimes b_{(0)1} \otimes b_{(0)2} = b_{(-1)} b_{2(-1)} \otimes b_{1(0)} \otimes b_{2(0)} \quad (3.1.11)$$

which is equivalent with saying that Δ_B is H -colinear (as B is a bialgebra in ${}^H_H\mathcal{YD}$). Furthermore, there exists a Hopf algebra projection

$$H \begin{array}{c} \xrightarrow{i} \\ \xleftarrow{p} \end{array} B \rtimes H$$

I.e. i and p are Hopf algebra maps and $p \circ i = id_H$. i and p are given by $i(h) = 1 \times h$ and $p(b \times h) = \varepsilon_B(b)h$. In particular, as coalgebra morphisms, they induce functors between (bi)comodule categories

$$\begin{aligned} I_l &: {}^H\mathcal{M} \longrightarrow {}^{B \rtimes H}\mathcal{M} \\ I_r &: \mathcal{M}^H \longrightarrow \mathcal{M}^{B \rtimes H} \\ P_l &: {}^{B \rtimes H}\mathcal{M} \longrightarrow {}^H\mathcal{M} \\ P_r &: \mathcal{M}^{B \rtimes H} \longrightarrow \mathcal{M}^H \end{aligned}$$

and similar for the -bicomodule categories. E.g., the functor I_l maps a comodule (M, ρ_M) with $\rho_M(m) = m_{(-1)} \otimes m_{(0)}$ to (M, χ_l) where $\chi_l(m) = i(m_{(-1)}) \otimes m_{(0)} = 1 \times m_{(-1)} \otimes m_{(0)}$. For $(D, \chi_l) \in {}^{B \rtimes H}\mathcal{M}$, with $\chi_l(d) = d_{\langle -1 \rangle} \otimes d_{\langle 0 \rangle}$, we have $P_l(D, \chi_l) = (D, \rho_D)$ where $\rho_D(n) = p(d_{\langle -1 \rangle}) \otimes d_{\langle 0 \rangle} = (\varepsilon_B \otimes H)(d_{\langle -1 \rangle}) \otimes d_{\langle 0 \rangle}$. We will often, without explicit mentioning, make use of this property. For example, it makes sense to say that a morphism $\nu : H \rightarrow D$, with $D \in {}^{B \rtimes H}\mathcal{M}$ (and notation as above), is left $B \rtimes H$ -colinear. Namely H has a $B \rtimes H$ -comodule structure given by $I_l(H, \Delta)$. Thus the left $B \rtimes H$ -colinearity is equivalent to

$$1 \times h_1 \otimes \nu(h_2) = \nu(h)_{\langle -1 \rangle} \otimes \nu(h)_{\langle 0 \rangle}$$

for $h \in H$.

The morphism $B \otimes \varepsilon_H : B \rtimes H \rightarrow B$ is in general not a Hopf algebra map. It is a coalgebra map however. Hence, we also have functors

$$\begin{aligned} Q_l &: {}^{B \rtimes H}\mathcal{M} \longrightarrow {}^B\mathcal{M} \\ Q_r &: \mathcal{M}^{B \rtimes H} \longrightarrow \mathcal{M}^B \end{aligned}$$

For the sake of convenience, we will denote the morphism $B \otimes \varepsilon_H$ by q throughout this chapter.

Lemma 3.1.1. *For $b, c \in B$ and $h, g \in H$ we have*

$$q((b \times h)_1) \otimes p((b \times h)_2) = b \times h \tag{3.1.12}$$

$$\begin{aligned} p((b \times h)_1) \otimes q((b \times h)_2) \\ = q((b \times h)_{1(-1)})p((b \times h)_2) \otimes q((b \times h)_{1(0)}) \end{aligned} \tag{3.1.13}$$

$$\begin{aligned} q((b \times h)_1)(p((b \times h)_2) \cdot q((c \times g))) \\ = q((b \times h)(c \times g)) \end{aligned} \tag{3.1.14}$$

$$q(S(b \times h)) = S_H(b_{(-1)}h) \cdot S_B(b_{(0)}) \tag{3.1.15}$$

Proof.

(3.1.12) Trivial.

(3.1.13) It is easy to see that both sides equal $b_{(-1)}h \otimes b_{(0)}$.

(3.1.14) Both sides equal $b(h \cdot c)\varepsilon(g)$.

(3.1.15) Immediate. □

We have introduced the necessary notation and definitions to extend B -bicomodule algebras in ${}^H_H\mathcal{YD}$ to $B \rtimes H$ -bicomodule algebras.

Proposition 3.1.2. *Let A be a B -bicomodule algebra in ${}^H_H\mathcal{YD}$. We can define a $B \rtimes H$ -bicomodule structure on the smash product $A\#H$. The left and right comodule structure are defined by*

$$\begin{aligned}\chi_l : A\#H &\rightarrow B \rtimes H \otimes A\#H \\ \chi_l(a\#h) &= (a^{[-1]} \times a^{[0]}_{(-1)}h_1) \otimes (a^{[0]}_{(0)}\#h_2) \\ \chi_r : A\#H &\rightarrow A\#H \otimes B \rtimes H \\ \chi_r(a\#h) &= (a^{[0]}\#a^{[1]}_{(-1)}h_1) \otimes (a^{[1]}_{(0)} \times h_2)\end{aligned}$$

Note that for $A = B$ we reobtain (both for χ_l and for χ_r) the comultiplication of the Radford biproduct $B \rtimes H$.

Proof. Let $a, c \in A$ and $h, g \in H$.

- $A\#H$ is a left $B \rtimes H$ -comodule.

$$\begin{aligned}&(id \otimes \chi_l) \circ \chi_l(a\#h) \\ &= (a^{[-1]} \times a^{[0]}_{(-1)}h_1) \otimes \chi_l(a^{[0]}_{(0)}\#h_2) \\ &= (a^{[-1]} \times a^{[0]}_{(-1)}h_1) \otimes (a^{[0]}_{(0)}^{[-1]} \times a^{[0]}_{(0)}^{[0]}_{(-1)}h_2) \otimes (a^{[0]}_{(0)}^{[0]}_{(0)}\#h_3) \\ &= (a^{[-1]} \times a^{[0]^{[0]}}_{(-1)}a^{[0]^{[0]}}_{(-1)}h_1) \otimes (a^{[0]^{[0]}}_{(0)} \times a^{[0]^{[0]}}_{(0)(-1)}h_2) \\ &\quad \otimes (a^{[0]^{[0]}}_{(0)(0)}\#h_3) \quad \text{by (3.1.7)} \\ &= (a^{[-2]} \times a^{[-1]}_{(-1)}a^{[0]}_{(-2)}h_1) \otimes (a^{[-1]}_{(0)} \times a^{[0]}_{(-1)}h_2) \otimes (a^{[0]}_{(0)}\#h_3) \\ &= (a^{[-1]}_1 \times a^{[-1]}_{2(-1)}(a^{[0]}_{(-1)}h_1)_1) \otimes (a^{[-1]}_{2(0)} \times (a^{[0]}_{(-1)}h_1)_2) \otimes (a^{[0]}_{(0)}\#h_2) \\ &= \Delta(a^{[-1]} \times a^{[0]}_{(-1)}h_1) \otimes (a^{[0]}_{(0)}\#h_2) \\ &= (\Delta \otimes id) \circ \chi_l(a\#h)\end{aligned}$$

- $A\#H$ is a right $B \times H$ -comodule.

$$\begin{aligned}
& (\chi_r \otimes id) \circ \chi_r(a\#h) \\
&= \chi_r(a^{[0]}\#a^{[1]}_{(-1)}h_1) \otimes (a^{[1]}_{(0)} \times h_2) \\
&= (a^{[0][0]}\#a^{[0][1]}_{(-1)}(a^{[1]}_{(-1)}h_1)_1) \otimes (a^{[0][1]}_{(0)} \times (a^{[1]}_{(-1)}h_1)_2) \\
&\quad \otimes (a^{[1]}_{(0)} \times h_2) \\
&= (a^{[0]}\#a^{[1]}_{(-1)}a^{[2]}_{(-1)1}h_1) \otimes (a^{[1]}_{(0)} \times a^{[2]}_{(-1)2}h_2) \otimes (a^{[1]}_{(0)} \times h_3) \\
&= (a^{[0]}\#a^{[1]}_{(-1)}a^{[2]}_{(-1)1}h_1) \otimes (a^{[1]}_{(0)} \times a^{[2]}_{(-1)2}h_2) \otimes (a^{[1]}_{(0)} \times h_3)
\end{aligned}$$

while

$$\begin{aligned}
& (id \otimes \Delta) \circ \chi_r(a\#h) \\
&= (a^{[0]}\#a^{[1]}_{(-1)}h_1) \otimes \Delta(a^{[1]}_{(0)} \times h_2) \\
&= (a^{[0]}\#a^{[1]}_{(-1)}h_1) \otimes (a^{[1]}_{(0)1} \times a^{[1]}_{(0)2(-1)}h_2) \otimes (a^{[1]}_{(0)2(0)} \times h_3) \\
&= (a^{[0]}\#a^{[1]}_{1(-1)}a^{[1]}_{2(-1)}h_1) \otimes (a^{[1]}_{1(0)} \times a^{[1]}_{2(0)(-1)}h_2) \\
&\quad \otimes (a^{[1]}_{2(0)(0)} \times h_3) \quad \text{by (3.1.11)} \\
&= (a^{[0]}\#a^{[1]}_{(-1)}a^{[2]}_{(-1)}h_1) \otimes (a^{[1]}_{(0)} \times a^{[2]}_{(0)(-1)}h_2) \otimes (a^{[2]}_{(0)(0)} \times h_3)
\end{aligned}$$

which equals $(\chi_r \otimes id) \circ \chi_r(a\#h)$ because of the H -comodule property of B .

- $A\#H$ is a $B \times H$ -bicomodule.

$$\begin{aligned}
& (id \otimes \chi_r) \circ \chi_l(a\#h) \\
&= (a^{[-1]} \times a^{[0]}_{(-1)}h_1) \otimes \chi_r(a^{[0]}_{(0)}\#h_2) \\
&= (a^{[-1]} \times a^{[0]}_{(-1)}h_1) \otimes (a^{[0]}_{(0)}\#a^{[0]}_{(0)}\#a^{[1]}_{(-1)}h_2) \\
&\quad \otimes (a^{[0]}_{(0)}\#a^{[1]}_{(0)} \times h_3) \\
&= (a^{[-1]} \times a^{[0][0]}_{(-1)}a^{[0][1]}_{(-1)}h_1) \otimes (a^{[0][0]}_{(0)}\#a^{[0][1]}_{(0)(-1)}h_2) \\
&\quad \otimes (a^{[0][1]}_{(0)(0)} \times h_3) \quad \text{by (3.1.8)} \\
&= (a^{[-1]} \times a^{[0][0]}_{(-1)}a^{[0][1]}_{(-1)1}h_1) \otimes (a^{[0][0]}_{(0)}\#a^{[0][1]}_{(-1)2}h_2) \\
&\quad \otimes (a^{[0][1]}_{(0)} \times h_3) \quad \text{by (3.1.8)} \\
&= (a^{[0][-1]} \times a^{[0][0]}_{(-1)}a^{[1]}_{(-1)1}h_1) \otimes (a^{[0][0]}_{(0)}\#a^{[1]}_{(-1)(2)}h_2) \\
&\quad \otimes (a^{[1]}_{(0)} \times h_3) \quad \text{by (3.1.4)} \\
&= (a^{[0][-1]} \times a^{[0][0]}_{(-1)}(a^{[1]}_{(-1)}h_1)_1) \otimes (a^{[0][0]}_{(0)}\#(a^{[1]}_{(-1)}h_1)_2) \\
&\quad \otimes (a^{[1]}_{(0)} \times h_2)
\end{aligned}$$

$$\begin{aligned}
&= \chi_l(a^{[0]} \# a^{[1]}_{(-1)} h_1) \otimes (a^{[1]}_{(0)} \times h_2) \\
&= (\chi_l \otimes id) \circ \chi_r(a \# h)
\end{aligned}$$

- $A \# H$ is a left $B \rtimes H$ -comodule algebra.

$$\begin{aligned}
&\chi_l((a \# h)(c \# g)) \\
&= \chi_l(a(h_1 \cdot c) \# h_2 g) \\
&= ((a(h_1 \cdot c))^{[-1]} \times (a(h_1 \cdot c))^{[0]}_{(-1)} h_2 g_1) \otimes ((a(h_1 \cdot c))^{[0]}_{(0)} \# h_3 g_2) \\
&= (a^{[-1]}(a^{[0]}_{(-1)} \cdot (h_1 \cdot c)^{[-1]}) \times (a^{[0]}_{(0)} (h_1 \cdot c)^{[0]}_{(-1)} h_2 g_1) \\
&\quad \otimes ((a^{[0]}_{(0)} (h_1 \cdot c)^{[0]}_{(0)}) \# h_3 g_2) \quad \text{by (3.1.9)} \\
&= (a^{[-1]}(a^{[0]}_{(-1)} h_1 \cdot c^{[-1]}) \times (a^{[0]}_{(0)} (h_2 \cdot c^{[0]}_{(-1)}) h_3 g_1) \\
&\quad \otimes ((a^{[0]}_{(0)} (h_2 \cdot c^{[0]}_{(0)})) \# h_4 g_2) \quad \text{by (3.1.5)} \\
&= (a^{[-1]}(a^{[0]}_{(-1)} h_1 \cdot c^{[-1]}) \times a^{[0]}_{(0)(-1)} (h_2 \cdot c^{[0]}_{(-1)}) h_3 g_1) \\
&\quad \otimes (a^{[0]}_{(0)(0)} (h_2 \cdot c^{[0]}_{(0)}) \# h_4 g_2) \quad \text{by (3.1.3)} \\
&= (a^{[-1]}(a^{[0]}_{(-1)1} h_1 \cdot c^{[-1]}) \times a^{[0]}_{(-1)2} h_2 c^{[0]}_{(-1)} S(h_4) h_5 g_1) \\
&\quad \otimes (a^{[0]}_{(0)} (h_3 \cdot c^{[0]}_{(0)}) \# h_6 g_2) \quad \text{by (3.1)} \\
&= (a^{[-1]}((a^{[0]}_{(-1)} h_1)_1 \cdot c^{[-1]}) \times (a^{[0]}_{(-1)} h_1)_2 c^{[0]}_{(-1)} g_1) \\
&\quad \otimes (a^{[0]}_{(0)} (h_2 \cdot c^{[0]}_{(0)}) \# h_3 g_2) \\
&= (a^{[-1]} \times a^{[0]}_{(-1)} h_1)(c^{[-1]} \times g_1) \otimes (a^{[0]}_{(0)} \# h_2)(c^{[0]}_{(0)} \# g_2) \\
&= ((a^{[-1]} \times a^{[0]}_{(-1)} h_1) \otimes (a^{[0]}_{(0)} \# h_2))((c^{[-1]} \times g_1) \otimes (c^{[0]}_{(0)} \# g_2)) \\
&= \chi_l(a \# h) \chi_l(c \# g)
\end{aligned}$$

- $A \# H$ is a right $B \rtimes H$ -comodule algebra.

$$\begin{aligned}
&\chi_r((a \# h)(c \# g)) \\
&= \chi_r(a(h_1 \cdot c) \# h_2 g) \\
&= ((a(h_1 \cdot c))^{[0]} \# (a(h_1 \cdot c))^{[1]}_{(-1)} h_2 g_1) \otimes ((a(h_1 \cdot c))^{[1]}_{(0)} \times h_3 g_2) \\
&= (a^{[0]}(a^{[1]}_{(-1)} \cdot (h_1 \cdot c)^{[0]}) \# (a^{[1]}_{(0)} (h_1 \cdot c)^{[1]}_{(-1)} h_2 g_1) \\
&\quad \otimes ((a^{[1]}_{(0)} (h_1 \cdot c)^{[1]}_{(0)}) \times h_3 g_2) \quad \text{by (3.1.10)} \\
&= (a^{[0]}(a^{[1]}_{(-1)} h_1 \cdot c^{[0]}) \# (a^{[1]}_{(0)} (h_2 \cdot c^{[1]}_{(-1)}) h_3 g_1) \\
&\quad \otimes ((a^{[1]}_{(0)} (h_2 \cdot c^{[1]}_{(0)})) \times h_4 g_2) \quad \text{by (3.1.6)}
\end{aligned}$$

$$\begin{aligned}
&= (a^{[0]}(a^{[1]}_{(-1)}h_1 \cdot c^{[0]})\#a^{[1]}_{(0)(-1)}(h_2 \cdot c^{[1]})_{(-1)}h_3g_1) \\
&\quad \otimes (a^{[1]}_{(0)(0)}(h_2 \cdot c^{[1]})_{(0)} \times h_4g_2) \quad \text{by (3.1.6)} \\
&= (a^{[0]}(a^{[1]}_{(-1)1}h_1 \cdot c^{[0]})\#a^{[1]}_{(-1)2}h_2c^{[1]}_{(-1)}S(h_4)h_5g_1) \\
&\quad \otimes (a^{[1]}_{(0)}(h_3 \cdot c^{[1]}_{(0)}) \times h_6g_2) \quad \text{by (3.1)} \\
&= (a^{[0]}((a^{[1]}_{(-1)}h_1)_1 \cdot c^{[0]})\#(a^{[1]}_{(-1)}h_1)_2c^{[1]}_{(-1)}g_1) \\
&\quad \otimes (a^{[1]}_{(0)}(h_2 \cdot c^{[1]}_{(0)}) \times h_3g_2) \\
&= (a^{[0]}\#a^{[1]}_{(-1)}h_1)(c^{[0]}\#c^{[1]}_{(-1)}g_1) \otimes (a^{[1]}_{(0)} \times h_2)(c^{[1]}_{(0)} \times g_2) \\
&= ((a^{[0]}\#a^{[1]}_{(-1)}h_1) \otimes (a^{[1]}_{(0)} \times h_2))((c^{[0]}\#c^{[1]}_{(-1)}g_1) \otimes (c^{[1]}_{(0)} \times g_2)) \\
&= \chi_r(a\#h)\chi_r(c\#g)
\end{aligned}$$

□

Remark 3.1.3. Due to the lack of left-right symmetry of the Radford biproduct and of the smash product, not every proof of a left-sided claim carries over verbatim to their 'equivalent' right-sided statement. Therefore, we will usually opt for completeness and provide proofs for the both the left- and right-sided statement.

We can now prove that this extending process sends braided B -bi-Galois objects in ${}^H_H\mathcal{YD}$ to bi-Galois objects over the k -Hopf algebra $B \rtimes H$.

Lemma 3.1.4. *Let A be a B -bi-Galois object in ${}^H_H\mathcal{YD}$.*

Then ${}^{co(B \rtimes H)}(A\#H) = (A\#H)^{co(B \rtimes H)} = k$.

Proof. First, let $\sum a_i\#h_i \in (A\#H)^{co(B \rtimes H)}$, i.e.

$$\begin{aligned}
\sum (a_i\#h_i) \otimes (1_B \times 1_H) &= \chi_r(a\#h) \\
&= \sum (a_i^{[0]}\#a_i^{[1]}_{(-1)}h_{i1}) \otimes (a_i^{[1]}_{(0)} \times h_{i2})
\end{aligned}$$

By applying $A \otimes \varepsilon_H \otimes B \otimes \varepsilon_H$, we get

$$\begin{aligned}
\sum a_i\varepsilon(h_i) \otimes 1_B &= \sum a_i^{[0]}\varepsilon(h_i) \otimes a_i^{[1]} \\
&= \chi^+(\sum a_i\varepsilon(h_i))
\end{aligned}$$

Thus $\sum a_i\varepsilon(h_i) \in A^{coB} = k1_A$, say $\sum a_i\varepsilon(h_i) \in A^{coB} = \lambda 1_A$. Now, by applying $A \otimes \varepsilon_H \otimes \varepsilon_B \otimes H$, we obtain

$$\begin{aligned}
\lambda 1_A \otimes 1_H &= \sum a_i\varepsilon(h_i) \otimes 1_H = \sum a_i^{[0]}\varepsilon(a_i^{[1]}_{(-1)}h_{i1})\varepsilon(a_i^{[1]}_{(0)}) \otimes h_{i2} \\
&= \sum a_i^{[0]}\varepsilon(a_i^{[1]}) \otimes h_i \\
&= \sum a_i \otimes h_i
\end{aligned}$$

Hence we have proven $(A\#H)^{\text{co}(B\times H)} = k$. The proof for ${}^{\text{co}(B\times H)}(A\#H) = k$ is similar but involves the braiding of ${}^H_H\mathcal{YD}$. Take $\sum a_i\#h_i \in {}^{\text{co}(B\times H)}(A\#H)$. We have

$$\begin{aligned} \sum (1_B \times 1_H) \otimes (a_i\#h_i) &= \chi_l(a_i\#h_i) \\ &= \sum (a_i^{[-1]} \times a_i^{[0]}_{(-1)}h_{i1}) \otimes (a_i^{[0]}_{(0)}\#h_{i2}) \end{aligned}$$

Apply $B \otimes \varepsilon_H \otimes A \otimes \varepsilon_H$, then

$$\begin{aligned} \sum 1_B \otimes a_i\varepsilon(h_i) &= \sum a_i^{[-1]} \otimes a_i^{[0]}\varepsilon(h_i) \\ &= \chi^-(\sum a_i\varepsilon(h_i)) \end{aligned}$$

or $\sum a_i\varepsilon(h_i) \in {}^{\text{co}B}A = k1_A$, say $\sum a_i\varepsilon(h_i) = \lambda'1_A$. Now we apply $\varepsilon_B \otimes H \otimes A \otimes \varepsilon_H$ to obtain

$$\begin{aligned} \sum 1_H \otimes a_i\varepsilon(h_i) &= \sum a_{i(-1)}h_i \otimes a_{i(0)} \\ &= \phi(\sum a_i \otimes h_i) \end{aligned}$$

Thus

$$\begin{aligned} \sum a_i \otimes h_i &= \phi^{-1}(\sum 1_H \otimes a_i\varepsilon(h_i)) \\ &= \lambda'\phi^{-1}(1_H \otimes 1_A) \\ &= \lambda'(1_A \otimes 1_H) \end{aligned}$$

so $\sum a_i\#h_i \in k(1_A \otimes 1_H)$, finishing the proof. \square

As A is a right B -Galois object in ${}^H_H\mathcal{YD}$, the canonical map

$$\text{can}_+ : A \otimes A \rightarrow A \otimes B : a \otimes c \mapsto ac^{[0]} \otimes c^{[1]}$$

is an isomorphism. Let $\gamma = (\text{can}_+)^{-1} \circ (\eta_A \otimes B)$ be as defined in (1.4.4). Let's introduce following notation

$$\gamma(b) = (\text{can}_+)^{-1}(1 \otimes b) = \sum_i X_i(b) \otimes Y_i(b) \in A \otimes A \quad \forall b \in B \quad (3.1.16)$$

For simplicity the sum sign will sometimes be omitted; $\gamma(b) = X_i(b) \otimes Y_i(b)$. We can reformulate the identities stated in Lemma 1.4.3. We will only formulate those needed for the remainder of the chapter.

Lemma 3.1.5. *For $a \in A$ and $b \in B$, we have*

$$X_i(b) \otimes Y_i(b)^{[0]} \otimes Y_i(b)^{[1]} = X_i(b_1) \otimes Y_i(b_1) \otimes b_2 \quad (3.1.17)$$

$$X_i(b)Y_i(b) = \varepsilon_B(b)1_A \quad (3.1.18)$$

$$a^{[0]}X_i(a^{[1]}) \otimes Y_i(a^{[1]}) = 1_A \otimes a \quad (3.1.19)$$

As A is also a left B -Galois object A in ${}^H_H\mathcal{YD}$, we can introduce a left-analogue of γ , say

$$\gamma' = (B \xrightarrow{B \otimes \eta_A} B \otimes A \xrightarrow{(can_-)^{-1}} A \otimes A)$$

Let's denote

$$\gamma'(b) = (can_-)^{-1}(b \otimes 1) = U_i(b) \otimes V_i(b) \in A \otimes A \quad (3.1.20)$$

for $b \in B$. Then

Lemma 3.1.6. *For $a \in A$ and $b \in B$, we have*

$$U_i(b)^{[-1]} \otimes U_i(b)^{[0]} V_i(b) = b \otimes 1_A \quad (3.1.21)$$

$$U_i(a^{[-1]}) \otimes V_i(a^{[-1]}) a^{[0]} = a \otimes 1_A \quad (3.1.22)$$

Proof. These identities can be obtained by taking mirror-images of the braided diagrams in Lemma 1.4.3. \square

Proposition 3.1.7. *Let A be a B -bi-Galois object in ${}^H_H\mathcal{YD}$. Then $A \# H$ is a bi-Galois object over $B \rtimes H$.*

Proof. By Lemma 3.1.4, it suffices to show that the left and right canonical morphisms

$$\begin{aligned} can_l : A \# H \otimes A \# H &\rightarrow B \rtimes H \otimes A \# H, \\ can_l(a \# h \otimes c \# g) &= \chi_l(a \# h)((1_B \times 1_H) \otimes (c \# g)) \\ &= (a^{[-1]} \times a^{[0]}_{(-1)} h_1) \otimes ((a^{[0]}_{(0)} \# h_2)(c \# g)) \\ &= (a^{[-1]} \times a^{[0]}_{(-1)} h_1) \otimes (a^{[0]}_{(0)}(h_2 \cdot c) \# h_3 g) \end{aligned}$$

and

$$\begin{aligned} can_r : A \# H \otimes A \# H &\rightarrow A \# H \otimes B \rtimes H, \\ can_r(a \# h \otimes c \# g) &= ((a \# h) \otimes (1_B \times 1_H)) \chi_r(c \# g) \\ &= ((a \# h)(c^{[0]} \# c^{[1]}_{(-1)} g_1)) \otimes (c^{[1]}_{(0)} \times g_2) \\ &= (a(h_1 \cdot c^{[0]}) \# h_2 c^{[1]}_{(-1)} g_1) \otimes (c^{[1]}_{(0)} \times g_2) \end{aligned}$$

are bijective.

We claim that the inverse of can_l is given by

$$\begin{aligned} can_l^{-1}(b \times h \otimes a \# g) &= (U_i(b) \# (V_i(b)_{(-1)} h)_1) \\ &\quad \otimes (S_H((V_i(b)_{(-1)} h)_3) \cdot (V_i(b)_{(0)} a) \# S_H((V_i(b)_{(-1)} h)_2) g) \end{aligned}$$

Indeed

$$\begin{aligned}
& \text{can}_l \circ \text{can}_l^{-1}(b \times h \otimes a \# g) \\
&= \text{can}_l((U_i(b) \# (V_i(b)_{(-1)}h)_1) \\
&\quad \otimes (S_H((V_i(b)_{(-1)}h)_3) \cdot (V_i(b)_{(0)}a) \# S_H((V_i(b)_{(-1)}h)_2)g)) \\
&= (U_i(b)^{[-1]} \times U_i(b)^{[0]}_{(-1)}(V_i(b)_{(-1)}h)_1) \\
&\quad \otimes (U_i(b)^{[0]}_{(0)}((V_i(b)_{(-1)}h)_2 S_H((V_i(b)_{(-1)}h)_5) \cdot (V_i(b)_{(0)}a)) \\
&\quad \quad \quad \# (V_i(b)_{(-1)}h)_3 S_H((V_i(b)_{(-1)}h)_4)g) \\
&= (U_i(b)^{[-1]} \times U_i(b)^{[0]}_{(-1)}V_i(b)_{(-1)}h) \otimes (U_i(b)^{[0]}_{(0)}V_i(b)_{(0)}a \# g) \\
&= (U_i(b)^{[-1]} \times (U_i(b)^{[0]}V_i(b))_{(-1)}h) \otimes ((U_i(b)^{[0]}V_i(b))_{(0)}a \# g) && \text{by (3.1.3)} \\
&= (b \times 1_{A(-1)}h) \otimes (1_{A(0)}a \# g) && \text{by (3.1.21)} \\
&= (b \times h) \otimes (a \# g)
\end{aligned}$$

$$\begin{aligned}
& \text{can}_l^{-1} \circ \text{can}_l(a \# h \otimes c \# g) \\
&= \text{can}_l^{-1}((a^{[-1]} \times a^{[0]}_{(-1)}h_1) \otimes (a^{[0]}_{(0)}(h_2 \cdot c) \# h_3g)) \\
&= (U_i(a^{[-1]}) \# (V_i(a^{[-1]})_{(-1)}a^{[0]}_{(-1)}h_1)_1) \\
&\quad \otimes (S_H((V_i(a^{[-1]})_{(-1)}a^{[0]}_{(-1)}h_1)_3) \cdot (V_i(a^{[-1]})_{(0)}a^{[0]}_{(0)}(h_2 \cdot c)) \\
&\quad \quad \quad \# S_H((V_i(a^{[-1]})_{(-1)}a^{[0]}_{(-1)}h_1)_2)h_3g) \\
&= (U_i(a^{[-1]}) \# ((V_i(a^{[-1]})a^{[0]})_{(-1)}h_1)_1) \\
&\quad \otimes (S_H(((V_i(a^{[-1]})a^{[0]})_{(-1)}h_1)_3) \cdot ((V_i(a^{[-1]})a^{[0]})_{(0)}(h_2 \cdot c)) \\
&\quad \quad \quad \# S_H(((V_i(a^{[-1]})a^{[0]})_{(-1)}h_1)_2)h_3g) && \text{by (3.1.3)} \\
&= (a \# h_1) \otimes (S_H(h_3) \cdot (h_4 \cdot c) \# S_H(h_2)h_5g) && \text{by (3.1.22)} \\
&= (a \# h) \otimes (c \# g)
\end{aligned}$$

Finally, the inverse of can_r is defined by

$$\begin{aligned}
& \text{can}_r^{-1}(a \# g \otimes b \times h) \\
&= (a((gS_H(b_{(-1)}h_1))_1 \cdot X_i(b_{(0)})) \# (gS_H(b_{(-1)}h_1))_2) \otimes (Y_i(b_{(0)}) \# h_2)
\end{aligned}$$

We verify

$$\begin{aligned}
& \text{can}_r \circ \text{can}_r^{-1}(a \# g \otimes b \times h) \\
&= \text{can}_r((a((gS_H(b_{(-1)}h_1))_1 \cdot X_i(b_{(0)})) \\
&\quad \quad \quad \# (gS_H(b_{(-1)}h_1))_2) \otimes (Y_i(b_{(0)}) \# h_2)) \\
&= (a((gS_H(b_{(-1)}h_1))_1 \cdot X_i(b_{(0)}))(gS_H(b_{(-1)}h_1))_2 \cdot Y_i(b_{(0)})^{[0]})
\end{aligned}$$

$$\begin{aligned}
& \#(gS_H(b_{(-1)}h_1))_3 Y_i(b_{(0)})^{[1]}_{(-1)} h_2 \otimes (Y_i(b_{(0)})^{[1]}_{(0)} \times h_3) \\
= & (a((gS_H(b_{(-1)}h_1))_1 \cdot (X_i(b_{(0)})Y_i(b_{(0)})^{[0]}))) \\
& \#(gS_H(b_{(-1)}h_1))_2 Y_i(b_{(0)})^{[1]}_{(-1)} h_2 \otimes (Y_i(b_{(0)})^{[1]}_{(0)} \times h_3) \quad \text{by (3.1.2)} \\
= & (a((gS_H(b_{(-1)}h_1))_1 \cdot (X_i(b_{(0)1})Y_i(b_{(0)1})))) \#(gS_H(b_{(-1)}h_1))_2 b_{(0)2(-1)} h_2 \\
& \otimes (b_{(0)2(0)} \times h_3) \quad \text{by (3.1.17)} \\
= & (a((gS_H(b_{(-1)}h_1))_1 \cdot (\varepsilon_B(b_{(0)1})1_A))) \#(gS_H(b_{(-1)}h_1))_2 b_{(0)2(-1)} h_2 \\
& \otimes (b_{(0)2(0)} \times h_3) \quad \text{by (3.1.18)} \\
= & (a \# g S_H(b_{(-1)}h_1) b_{(0)(-1)} h_2) \otimes (b_{(0)(0)} \times h_3) \quad \text{by (3.1.2)} \\
= & (a \# g S_H(h_1) S_H(b_{(-1)1}) b_{(-1)2} h_2) \otimes (b_{(0)} \times h_3) \\
= & (a \# g) \otimes (b \times h)
\end{aligned}$$

and

$$\begin{aligned}
& can_r^{-1} \circ can_r(a \# h \otimes c \# g) \\
= & can_r^{-1}((a(h_1 \cdot c^{[0]}) \# h_2 c^{[1]}_{(-1)} g_1) \otimes (c^{[1]}_{(0)} \times g_2)) \\
= & (a(h_1 \cdot c^{[0]}))((h_2 c^{[1]}_{(-1)} g_1 S_H(c^{[1]}_{(0)(-1)} g_2))_1 \cdot X_i(c^{[1]}_{(0)(0)})) \\
& \#(h_2 c^{[1]}_{(-1)} g_1 S_H(c^{[1]}_{(0)(-1)} g_2))_2 \otimes (Y_i(c^{[1]}_{(0)(0)}) \# g_3) \\
= & (a(h_1 \cdot c^{[0]}))((h_2 c^{[1]}_{(-1)1} g_1 S_H(g_2) S_H(c^{[1]}_{(-1)2}))_1 \cdot X_i(c^{[1]}_{(0)})) \\
& \#(h_2 c^{[1]}_{(-1)1} g_1 S_H(g_2) S_H(c^{[1]}_{(-1)2}))_2 \otimes (Y_i(c^{[1]}_{(0)}) \# g_3) \\
= & (a(h_1 \cdot c^{[0]})(h_2 \cdot X_i(c^{[1]})) \# h_3) \otimes (Y_i(c^{[1]}) \# g) \\
= & (a(h_1 \cdot (c^{[0]} X_i(c^{[1]}))) \# h_2) \otimes (Y_i(c^{[1]}) \# g) \quad \text{by (3.1.2)} \\
= & (a(h_1 \cdot 1_A) \# h_2) \otimes (c \# g) \quad \text{by (3.1.19)} \\
= & (a \# h) \otimes (c \# g) \quad \text{by (3.1.2)}
\end{aligned}$$

□

The discussion above allows us to construct a map $BiGal(B) \rightarrow BiGal(B \times H)$.

Theorem 3.1.8. *The map $\xi : BiGal(B) \rightarrow BiGal(B \times H)$ sending an isomorphism class $[A]$ to the class $[A \# H]$ is a well-defined group homomorphism.*

Proof. If $[A] \in BiGal(B)$, then $[A \# H] \in BiGal(B \times H)$ by Proposition 3.1.7. To show that this map is well defined, suppose $[A] = [A'] \in BiGal(B)$. I.e. there exists a B -bilinear algebra isomorphism $f : A \rightarrow A'$ in ${}^H_H\mathcal{YD}$. Obviously, $f \otimes H$ defines a bijective map $A \# H \rightarrow A' \# H$. Moreover one can verify that $f \otimes H$ is a $B \times H$ -bilinear algebra isomorphism $A \# H \rightarrow A' \# H$, showing $[A \# H] = [A' \# H]$.

Indeed, take $a, c \in A$, $h, g \in H$, then

$f \otimes H$ is an algebra morphism;

$$\begin{aligned}
& (f \otimes H)((a \# h)(c \# g)) \\
&= (f \otimes H)(a(h_1 \cdot c) \# h_2 g) \\
&= f(a(h_1 \cdot c)) \# h_2 g \\
&= f(a)f(h_1 \cdot c) \# h_2 g && (f \text{ is an algebra map}) \\
&= f(a)(h_1 \cdot f(c)) \# h_2 g && (f \text{ is } H\text{-linear}) \\
&= (f(a) \# h)(f(c) \# g)
\end{aligned}$$

$f \otimes H$ is right $B \rtimes H$ -colinear;

$$\begin{aligned}
& \chi'_r \circ (f \otimes H)(a \# h) \\
&= \chi'_r(f(a) \# h) \\
&= (f(a)^{[0]} \# f(a)^{[1]}_{(-1)} h_1) \otimes (f(a)^{[1]}_{(0)} \times h_2) \\
&= (f(a)^{[0]} \# a^{[1]}_{(-1)} h_1) \otimes (a^{[1]}_{(0)} \times h_2) && (f \text{ is right } B\text{-colinear}) \\
&= (f \otimes H \otimes B \rtimes H) \circ \chi_r(a \# h)
\end{aligned}$$

$f \otimes H$ is left $B \rtimes H$ -colinear;

$$\begin{aligned}
& \chi'_l \circ (f \otimes H)(a \# h) \\
&= \chi'_l(f(a) \# h) \\
&= (f(a)^{[-1]} \times f(a)^{[0]}_{(-1)} h_1) \otimes (f(a)^{[0]}_{(0)} \# h_2) \\
&= (a^{[-1]} \times f(a)^{[0]}_{(-1)} h_1) \otimes (f(a)^{[0]}_{(0)} \# h_2) && (f \text{ is left } B\text{-colinear}) \\
&= (a^{[-1]} \times a^{[0]}_{(-1)} h_1) \otimes (f(a)^{[0]}_{(0)} \# h_2) && (f \text{ is } H\text{-colinear}) \\
&= (B \rtimes H \otimes f \otimes H) \circ \chi_l(a \# h)
\end{aligned}$$

It remains to show that ξ is a group homomorphism. It is already noted in Proposition 3.1.2, that for B itself, we obtain $\chi_l = \chi_r = \Delta_{B \rtimes H}$, hence $\xi(1) = 1$. Let $[A], [A'] \in \text{BiGal}(B)$. We have to show that $\xi([A][A']) = \xi([A \square_B A']) = [(A \square_B A') \# H]$ equals $\xi([A])\xi([A']) = [A \# H][A' \# H] = [(A \# H) \square (A' \# H)]$, where the unadorned cotensor product is over $B \rtimes H$, i.e. $\square = \square_{B \rtimes H}$. We do this by proving the existence of a $B \rtimes H$ -bilinear algebra homomorphism $\vartheta : (A \square_B A') \# H \rightarrow (A \# H) \square (A' \# H)$. Then by [12, Proposition 8.1.9], ϑ is bijective implying $[(A \square_B A') \# H] = [(A \# H) \square (A' \# H)]$. We stress the fact that the cotensor product $A \square_B A'$ is formed inside the category of ${}^H_H \mathcal{YD}$, in particular it has module and comodule structure given by

$$h \cdot (a_i \otimes a'_i) = h_1 \cdot a_i \otimes h_2 \cdot a'_i \quad (3.1.23)$$

$$\rho(a_i \otimes a'_i) = a_{i(-1)} a'_{i(-1)} \otimes a_{i(0)} \otimes a'_{i(0)} \quad (3.1.24)$$

for $h \in H$ and $a_i \otimes a'_i = \sum_i a_i \otimes a'_i \in A \square_B A'$ (we will often the sum sign). $A \square_B A'$ has braided product

$$(a_i \otimes a'_i)(c_j \otimes c'_j) = a_i(a'_{i(-1)} \cdot c) \otimes a'_{i(0)}c'_j \quad (3.1.25)$$

for $a_i \otimes a'_i, c_j \otimes c'_j \in A \square_B A'$. The left and right B -comodule structure of $A \square_B A'$ are given by $\chi_A^- \otimes A'$ and $A \otimes \chi_{A'}^+$, respectively.

Define

$$\begin{aligned} \vartheta : (A \square_B A') \# H &\rightarrow (A \# H) \square (A' \# H) \\ \vartheta((a_i \otimes a'_i) \# h) &= (a_i \# a'_{i(-1)} h_1) \otimes (a'_{i(0)} \# h_2) \end{aligned}$$

First note, since $a_i \otimes a'_i \in A \square_B A'$, we have

$$\begin{aligned} \chi_A^+(a_i) \otimes a'_i &= a_i \otimes \chi_{A'}^-(a'_i) \\ a_i^{[0]} \otimes a_i^{[1]} \otimes a'_i &= a_i \otimes a_i^{[-1]} \otimes a_i^{[0]} \end{aligned} \quad (3.1.26)$$

We show that $\vartheta((a_i \otimes a'_i) \# h) \in (A \# H) \square (A' \# H)$.

$$\begin{aligned} &\chi_r(a_i \# a'_{i(-1)} h_1) \otimes (a'_{i(0)} \# h_2) \\ &= (a_i^{[0]} \# a_i^{[1]}_{(-1)} a'_{i(-1)1} h_1) \otimes (a_i^{[1]}_{(0)} \times a'_{i(-1)2} h_2) \otimes (a'_{i(0)} \# h_3) \\ &= (a_i^{[0]} \# a_i^{[1]}_{(-1)} a'_{i(-1)} h_1) \otimes (a_i^{[1]}_{(0)} \times a'_{i(0)(-1)} h_2) \otimes (a'_{i(0)(0)} \# h_3) \\ &= (a_i \# a_i^{[-1]}_{(-1)} a_i^{[0]}_{(-1)} h_1) \otimes (a_i^{[-1]}_{(0)} \times a_i^{[0]}_{(0)(-1)} h_2) \otimes (a_i^{[0]}_{(0)(0)} \# h_3) \\ &\hspace{15em} \text{by (3.1.26)} \\ &= (a_i \# a'_{i(-1)} h_1) \otimes (a'_{i(0)}^{[-1]} \times a'_{i(0)}^{[0]}_{(-1)} h_2) \otimes (a'_{i(0)}^{[0]}_{(0)} \# h_3) \hspace{2em} \text{by (3.1.7)} \\ &= (a_i \# a'_{i(-1)} h_1) \otimes \chi_l(a'_{i(0)} \# h_2) \end{aligned}$$

Moreover, ϑ is an algebra map,

$$\begin{aligned} &\vartheta(((a_i \otimes a'_i) \# h)((c_j \otimes c'_j) \# g)) \\ &= \vartheta(((a_i \otimes a'_i) h_1 \cdot (c_j \otimes c'_j)) \# g) \\ &= \vartheta(((a_i \otimes a'_i)(h_1 \cdot c_j \otimes h_2 \cdot c'_j)) \# g) \hspace{2em} \text{by (3.1.23)} \\ &= \vartheta((a_i(a'_{i(-1)} h_1 \cdot c_j) \otimes a'_{i(0)}(h_2 \cdot c'_j)) \# h_3 g) \hspace{2em} \text{by (3.1.25)} \\ &= (a_i(a'_{i(-1)} h_1 \cdot c_j) \# (a'_{i(0)}(h_2 \cdot c'_j))_{(-1)} h_3 g_1) \otimes ((a'_{i(0)}(h_2 \cdot c'_j))_{(0)} \# h_4 g_2) \\ &= (a_i(a'_{i(-1)} h_1 \cdot c_j) \# a'_{i(0)(-1)}(h_2 \cdot c'_j)_{(-1)} h_3 g_1) \otimes (a'_{i(0)(0)}(h_2 \cdot c'_j)_{(0)} \# h_4 g_2) \\ &\hspace{15em} \text{by (3.1.3)} \\ &= (a_i(a'_{i(-1)1} h_1 \cdot c_j) \# a'_{i(-1)2} h_2 c'_{j(-1)} S_H(h_4) h_5 g_1) \otimes (a'_{i(0)}(h_3 \cdot c'_{j(0)}) \# h_6 g_2) \\ &\hspace{15em} \text{by (3.1)} \end{aligned}$$

$$\begin{aligned}
&= (a_i((a'_{i(-1)}h_1)_1 \cdot c_j) \# (a'_{i(-1)}h_1)_2 c'_{j(-1)}g_1) \otimes (a'_{i(0)}(h_2 \cdot c'_{j(0)}) \# h_3 g_2) \\
&= (a_i \# a'_{i(0)}h_1)(c_j \# c'_{j(-1)}g_1) \otimes (a'_{i(0)} \# h_2)(c'_{j(0)} \# g_2) \\
&= \vartheta((a_i \otimes a'_i) \# h) \vartheta((c_j \otimes c'_j) \# g)
\end{aligned}$$

Lastly, ϑ is left and right $B \rtimes H$ -colinear.

$$\begin{aligned}
&(B \rtimes H \otimes \vartheta) \circ \chi_l((a_i \otimes a'_i) \# h) \\
&= (B \rtimes H \otimes \vartheta)((a_i \otimes a'_i)^{[-1]} \times (a_i \otimes a'_i)^{[0]}_{(-1)}h_1) \otimes ((a_i \otimes a'_i)^{[0]}_{(0)} \# h_2) \\
&= (B \rtimes H \otimes \vartheta)((a_i^{[-1]} \times (a_i^{[0]} \otimes a'_i)_{(-1)}h_1) \otimes ((a_i^{[0]} \otimes a'_i)_{(0)} \# h_2)) \\
&= (B \rtimes H \otimes \vartheta)((a_i^{[-1]} \times a_i^{[0]}_{(-1)}a'_{i(-1)}h_1) \otimes ((a_i^{[0]}_{(0)} \otimes a'_{i(0)}) \# h_2)) \quad \text{by (3.1.24)} \\
&= (a_i^{[-1]} \times a_i^{[0]}_{(-1)}a'_{i(-1)}h_1) \otimes (a_i^{[0]}_{(0)} \# a'_{i(0)(-1)}h_2) \otimes (a'_{i(0)(0)} \# h_3) \\
&= (a_i^{[-1]} \times a_i^{[0]}_{(-1)}(a'_{i(-1)}h_1)_1) \otimes (a_i^{[0]}_{(0)} \# (a'_{i(-1)}h_1)_2) \otimes (a'_{i(0)} \# h_2) \\
&= \chi_l(a_i \# a'_{i(-1)}h_1) \otimes (a'_{i(0)} \# h_2) \\
&= (\chi_l \otimes A' \# H) \circ \vartheta((a_i \otimes a'_i) \# h)
\end{aligned}$$

and

$$\begin{aligned}
&(\vartheta \otimes B \rtimes H) \circ \chi_r((a_i \otimes a'_i) \# h) \\
&= (\vartheta \otimes B \rtimes H)((a_i \otimes a'_i)^{[0]} \# (a_i \otimes a'_i)^{[1]}_{(-1)}h_1) \otimes ((a_i \otimes a'_i)^{[1]}_{(0)} \times h_2) \\
&= (\vartheta \otimes B \rtimes H)((a_i \otimes a'_i)^{[0]} \# a_i'^{[1]}_{(-1)}h_1) \otimes (a_i'^{[1]}_{(0)} \times h_2) \\
&= (a_i \# a_i'^{[0]}_{(-1)}a_i'^{[1]}_{(-1)}h_1) \otimes (a_i'^{[0]}_{(0)} \# a_i'^{[1]}_{(-1)2}h_2) \otimes (a_i'^{[1]}_{(0)} \times h_2) \\
&= (a_i \# a_i'^{[0]}_{(-1)}a_i'^{[1]}_{(-1)}h_1) \otimes (a_i'^{[0]}_{(0)} \# a_i'^{[1]}_{(0)(-1)}h_2) \otimes (a_i'^{[1]}_{(0)(0)} \times h_2)
\end{aligned}$$

but also

$$\begin{aligned}
&(A \# H \otimes \chi_r) \circ \vartheta((a_i \otimes a'_i) \# h) \\
&= (A \# H \otimes \chi_r)((a_i \# a'_{i(-1)}h_1) \otimes (a'_{i(0)} \# h_2)) \\
&= (a_i \# a'_{i(-1)}h_1) \otimes (a'_{i(0)} \# a'_{i(0)}^{[1]}_{(-1)}h_2) \otimes (a'_{i(0)}^{[1]}_{(0)} \# h_3) \\
&= (a_i \# a_i'^{[0]}_{(-1)}a_i'^{[1]}_{(-1)}h_1) \otimes (a_i'^{[0]}_{(0)} \# a_i'^{[1]}_{(0)(-1)}h_2) \otimes (a_i'^{[1]}_{(0)(0)} \times h_2) \quad \text{by (3.1.8)}
\end{aligned}$$

□

In Section 3.7 we will present an example where the morphism ξ is neither injective nor surjective. It is however possible, in general, to describe its kernel and image. We start by giving a description for the image.

3.2 The image of ξ

First, let $D \in \text{Im}\xi$. I.e., $D = A\#H$ is obtained from $A \in \text{BiGal}(B)$ as in Proposition 3.1.7. We have

$$\begin{aligned}\chi_l(a\#h) &= (a^{[-1]} \times a^{[0]}_{(-1)}h_1) \otimes (a^{[0]}_{(0)}\#h_2) \\ \chi_r(a\#h) &= (a^{[0]}\#a^{[1]}_{(-1)}h_1) \otimes (a^{[1]}_{(0)} \times h_2)\end{aligned}$$

for $a \in A, h \in H$. A straightforward computation shows that the morphism $\nu : H \rightarrow A\#H, \nu(h) = 1\#h$ is a $B \rtimes H$ -bilinear algebra morphism.

The functors P_l and P_r (introduced in Section 3.1) induce an H -bicomodule structure on $A\#H$.

$$\begin{aligned}\rho^-(a\#h) &= a_{(-1)}h_1 \otimes (a_{(0)}\#h_2) \\ \rho^+(a\#h) &= (a\#h_1) \otimes h_2\end{aligned}$$

With these H -comodule structures, $\nu : H \rightarrow A\#H$ is also H -bilinear. Moreover, we immediately observe that $D^{\text{co}H} = A\#1 \cong A$ and as

$$\rho^-(a\#1) = a_{(-1)} \otimes (a_{(0)}\#1)$$

we can recover the original H -coaction on A . Likewise, Q_l and Q_r induce B -comodule structures on $A\#H$

$$\begin{aligned}\chi^-(a\#h) &= a^{[-1]} \otimes (a^{[0]}\#h) \\ \chi^+(a\#h) &= (a^{[0]}\#a^{[1]}_{(-1)}h) \otimes a^{[1]}_{(0)}\end{aligned}$$

In particular, for $A\#1$ we obtain

$$\begin{aligned}\chi^-(a\#1) &= a^{[-1]} \otimes (a^{[0]}\#1) \\ \chi^+(a\#1) &= (a^{[0]}\#a^{[1]}_{(-1)}) \otimes a^{[1]}_{(0)}\end{aligned}$$

Hence, χ^- restricted to A gives us the left B -coaction on A . χ^+ defined as above doesn't return the right B -coaction on A , moreover it doesn't necessarily give a B -coaction on A at all. However, if we denote $\chi_r(a\#h) = (a\#h)_{<0>} \otimes (a\#h)_{<1>}$, we do have

$$\begin{aligned} & ((a\#1)_{<0>} \nu^{-1}(p((a\#1)_{<1>}))) \otimes q((a\#1)_{<2>}) \tag{3.2.1} \\ &= ((a^{[0]}\#a^{[1]}_{(-1)}) \nu \circ S(p(a^{[1]}_{(0)1} \times a^{[1]}_{(0)2(-1)}))) \otimes q(a^{[1]}_{(0)2(0)} \times 1) \\ &= ((a^{[0]}\#a^{[1]}_{(-1)}) \nu \circ S(a^{[1]}_{(0)(-1)})) \otimes a^{[1]}_{(0)(0)} \\ &= ((a^{[0]}\#a^{[1]}_{(-1)1})(1\#S(a^{[1]}_{(-1)2}))) \otimes a^{[1]}_{(0)} \\ &= (a^{[0]}\#1) \otimes a^{[1]}\end{aligned}$$

thus we can retrieve the right B -coaction in this way. Finally, note that

$$\begin{aligned} & \nu(h_1)(a\#1)\nu(S(h_2)) \\ &= (1\#h_1)(a\#1)(1\#S(h_2)) \\ &= (h \cdot a)\#1 \end{aligned}$$

Hence, we can also recover the H -action on A from the data on $A\#H$.

We have seen how to reobtain A and all its (co)module structures from $A\#H$. In a similar way we can find a preimage for any $B \rtimes H$ -bi-Galois object D for which there exists a $B \rtimes H$ -bilinear algebra map $\nu : H \rightarrow D$. For this we need the structure theorem for bicomodule algebras.

Lemma 3.2.1. *Let F be an arbitrary k -Hopf algebra and D an F -bicomodule algebra with the property that there exists an F -bilinear algebra map $\nu : F \rightarrow D$. Then D is isomorphic (as a bicomodule algebra) to the smash product $A\#F$, where $A = D^{\text{co}F}$. Moreover, the multiplication on A is the restriction of the multiplication on D and A becomes a left-left Yetter-Drinfeld module algebra.*

Proof. Direct corollary of Theorem 2.1.9. In particular, $A = D^{\text{co}F}$ inherits a left F -comodule algebra structure from D and becomes a left F -module algebra via

$$x \cdot a = \nu(x_1)a\nu(S(x_2))$$

for $x \in F$ and $a \in A$. $A\#F$ is an F -bicomodule via

$$\begin{aligned} \rho^+(a\#x) &= a\#x_1 \otimes x_2 \\ \rho^-(a\#h) &= a_{(-1)}h_1 \otimes a_{(0)}\#h_2 \end{aligned}$$

Finally, the F -bilinear algebra isomorphism $A\#F \cong D$ is given by

$$\begin{aligned} \omega : A\#F &\rightarrow D, \quad \omega(a\#x) = a\nu(x) \\ \omega^{-1} : D &\rightarrow A\#F, \quad \omega^{-1}(d) = d_{(0)}\nu(S(d_{(1)}))\#d_{(2)} \end{aligned}$$

□

Let $D \in \text{BiGal}(B \rtimes H)$ with $\nu : H \rightarrow D$ a $B \rtimes H$ -bilinear algebra morphism. Then ν is also H -bilinear. Indeed by the left $B \rtimes H$ -colinearity of ν we have

$$\nu(h)_{\langle -1 \rangle} \otimes \nu(h)_{\langle 0 \rangle} = 1 \times h_1 \otimes \nu(h_2) \quad (3.2.2)$$

for $h \in H$. By applying the functor P_l we obtain

$$\nu(h)_{(-1)} \otimes \nu(h)_{(0)} = h_1 \otimes \nu(h_2) \quad (3.2.3)$$

thus ν is left H -colinear. Similarly, we have

$$\nu(h)_{<0>} \otimes \nu(h)_{<1>} = \nu(h_1) \otimes 1 \times h_2 \quad (3.2.4)$$

and

$$\nu(h)_{(0)} \otimes \nu(h)_{(1)} = \nu(h_1) \otimes h_2 \quad (3.2.5)$$

Since ν is an H -bilinear algebra morphism, we can apply Lemma 3.2.1 and obtain

$$D \cong D^{coH} \# H$$

as H -bicomodule algebras. Moreover, D^{coH} is a left-left Yetter-Drinfeld module where

$$\begin{aligned} h \cdot d &= \nu(h_1) d \nu(S(h_2)) \\ \rho^l(d) &= p(d_{<-1>}) \otimes d_{<0>} \end{aligned}$$

for $d \in D$ and $h \in H$. As in (2.1.5), there is a morphism

$$E : D \rightarrow D^{coH}, \quad d \mapsto d_{(0)} \nu(S(d_{(1)})) = d_{<0>} \nu(S(p(d_{<-1>}))) \quad (3.2.6)$$

We will now prove step by step that D^{coH} is a preimage of D .

Proposition 3.2.2. *Let D be as above. Then D^{coH} is a left B -comodule algebra in ${}^H_H\mathcal{YD}$.*

Proof. The functor Q_l turns D into a left B -comodule. Denote the coaction by χ^- with $\chi^-(d) = d^{[-1]} \otimes d^{[0]}$. Then

$$\begin{aligned} \chi^-(d) &= d^{[-1]} \otimes d^{[0]} \\ &= q(d_{<-1>}) \otimes d_{<0>} \end{aligned}$$

Furthermore

$$\begin{aligned} & d^{[-1]} \otimes \rho^r(d^{[0]}) \\ &= q(d_{<-1>}) \otimes d_{<0>(0)} \otimes d_{<0>(1)} \\ &= q(d_{(0)<-1>}) \otimes d_{(0)<0>} \otimes d_{(1)} \\ &= q(d_{<-1>}) \otimes d_{<0>} \otimes 1 \\ &= \chi^-(d) \otimes 1 \end{aligned}$$

for $d \in D^{coH}$. Hence $\chi^-(D^{coH}) \subset B \otimes D^{coH}$ and D^{coH} is a left B -subcomodule of D . Moreover, $\chi^- : D^{coH} \rightarrow B \otimes D^{coH}$ is left H -linear

$$\begin{aligned}
\chi^-(h \cdot d) &= \chi^-(\nu(h_1)d\nu(S(h_2))) \\
&= q((\nu(h_1)d\nu(S(h_2)))_{<-1>}) \otimes (\nu(h_1)d\nu(S(h_2)))_{<0>} \\
&= q(\nu(h_1)_{<-1>}d_{<-1>}\nu(S(h_2))_{<-1>}) \otimes \nu(h_1)_{<0>}d_{<0>}\nu(S(h_2))_{<0>} \\
&= q((1 \times h_1)d_{<-1>}(1 \times S(h_4)) \otimes \nu(h_2)d_{<0>}\nu(S(h_3))) && \text{by (3.2.2)} \\
&= q((1 \times h_1)d_{<-1>}(1 \times S(h_3)) \otimes h_2 \cdot d_{<0>}) \\
&= h_1 \cdot q(d_{<-1>}) \otimes h_2 \cdot d_{<0>} && \text{by (3.1.14)} \\
&= h \cdot \chi^-(d)
\end{aligned}$$

and left H -colinear since the following diagram commutes

$$\begin{array}{ccc}
D^{coH} & \xrightarrow{\chi^-} & B \otimes D^{coH} \\
\rho_{D^{coH}} \downarrow & & \downarrow \rho_{B \otimes D^{coH}} \\
H \otimes D^{coH} & \xrightarrow{H \otimes \chi^-} & H \otimes B \otimes D^{coH}
\end{array}$$

Indeed

$$\begin{aligned}
&(H \otimes \chi^-) \circ \rho_{D^{coH}}(d) \\
&= d_{(-1)} \otimes d_{(0)}^{[-1]} \otimes d_{(0)}^{[0]} \\
&= d_{(-1)} \otimes q(d_{(0)<-1>}) \otimes d_{(0)<0>} \\
&= p(d_{<-1>}) \otimes q(d_{<0><-1>}) \otimes d_{<0><0>} \\
&= p(d_{<-1>1}) \otimes q(d_{<-1>2}) \otimes d_{<0>}
\end{aligned}$$

while

$$\begin{aligned}
&\rho_{B \otimes D^{coH}} \circ \chi^-(d) \\
&= \rho_{B \otimes D^{coH}}(d^{[-1]} \otimes d^{[0]}) \\
&= d_{(-1)}^{[-1]} d_{(-1)}^{[0]} \otimes d_{(0)}^{[-1]} \otimes d_{(0)}^{[0]} \\
&= q(d_{<-1>})_{(-1)} d_{<0>(-1)} \otimes q(d_{<-1>})_{(0)} \otimes d_{<0> (0)} \\
&= q(d_{<-1>})_{(-1)} p(d_{<0><-1>}) \otimes q(d_{<-1>})_{(0)} \otimes d_{<0><0>} \\
&= q(d_{<-1>1})_{(-1)} p(d_{<-1>2}) \otimes q(d_{<-1>1})_{(0)} \otimes d_{<0>} \\
&= (H \otimes \chi^-) \circ \rho_{D^{coH}}(d) && \text{by (3.1.13)}
\end{aligned}$$

Finally, $\chi^- : D^{coH} \rightarrow B \otimes D^{coH}$ is an algebra morphism in ${}^H_H\mathcal{YD}$. I.e. we have to check that D^{coH} satisfies equation (3.1.9). Let $d, d' \in D^{coH}$, then

$$\begin{aligned}
& d^{[-1]}(d^{[0]}_{(-1)} \cdot d'^{[-1]}) \otimes d^{[0]}_{(0)} d'^{[0]} \\
&= q(d_{<-1>})(p(d_{<0><-1>} \cdot q(d'_{<-1>})) \otimes d_{<0><0>} d'_{<0>} \\
&= q(d_{<-1>1})(p(d_{<-1>2} \cdot q(d'_{<-1>})) \otimes d_{<0>} d'_{<0>} \\
&= q(d_{<-1>} d'_{<-1>}) \otimes d_{<0>} d'_{<0>} \quad \text{by (3.1.14)} \\
&= q((dd')_{<-1>}) \otimes (dd')_{<0>} \\
&= \chi^-(dd')
\end{aligned}$$

□

We have seen at the beginning of this section that similar tactics using Q_r will not work, as D^{coH} will not necessarily become a right B -subcomodule in this way. However, equation (3.2.1) gives an idea how to change our approach and how to define a right B -coaction on D^{coH} .

Remark 3.2.3. Let $d \in D^{coH}$. Then

$$d_{<0>} \otimes d_{<1>1} \otimes d_{<1>2} = d_{<0><0>} \otimes d_{<0><1>} \otimes d_{<1>}$$

Apply $D \otimes B \rtimes H \otimes p$

$$\begin{aligned}
d_{<0>} \otimes d_{<1>1} \otimes p(d_{<1>2}) &= d_{(0)<0>} \otimes d_{(0)<1>} \otimes d_{(1)} \\
&= d_{<0>} \otimes d_{<1>} \otimes 1
\end{aligned}$$

Apply $D \otimes q \otimes H$

$$\begin{aligned}
d_{<0>} \otimes q(d_{<1>1}) \otimes p(d_{<1>2}) &= d_{<0>} \otimes q(d_{<1>}) \otimes 1 \\
&= d_{<0>} \otimes d_{<1>} \quad \text{by (3.1.12)}
\end{aligned}$$

Hence we can assume

$$\chi_r(d) = d_{<0>} \otimes d_{<1>} \in D \otimes B \times 1 \quad (3.2.7)$$

We will use this extensively in the next proposition.

Proposition 3.2.4. *Let D be as above. Then D^{coH} is a right B -comodule algebra in ${}^H_H\mathcal{YD}$.*

Proof. Let χ^+ be the composition of the following morphisms.

$$D^{coH} \subset D \xrightarrow{\chi_r} D \otimes (B \times 1) \xrightarrow{E \otimes q} D^{coH} \otimes B$$

where $E : D \rightarrow D^{coH}$ is as in (3.2.6) and $q = B \otimes \varepsilon_H$ as before. Then

$$\begin{aligned}
\chi^+(d) &= (E \otimes id \otimes \varepsilon)(d_{<0>} \otimes d_{<1>}) \\
&= E(d_{<0>}) \otimes q(d_{<1>}) \\
&= d_{<0>(0)} \nu^{-1}(d_{<0>(1)}) \otimes q(d_{<1>}) \\
&= d_{<0><0>} \nu^{-1}(p(d_{<0><1>})) \otimes q(d_{<1>}) \\
&\stackrel{or}{=} d_{<0>} \nu^{-1}(p(d_{<1>1})) \otimes q(d_{<1>2}) = d_{<0>} \nu^{-1}(p(d_{<1>})) \otimes q(d_{<2>}) \\
&\stackrel{or}{=} d_{<0>} \nu^{-1}(q(d_{<1>}_{(-1)})) \otimes q(d_{<1>}_{(0)})
\end{aligned}$$

where the last equality follows from the fact that $d_{<0>} \otimes d_{<1>} \in D \otimes B \times 1$. Alternatively, say $\chi_r(d) = d_{<0>} \otimes d_{<1>} = d_i \otimes b_i \times 1$ (again by (3.2.7)), then

$$\chi^+(d) = d_i \nu(S(b_{i(-1)})) \otimes b_{i(0)}$$

By construction we already have $\chi^+(D^{coH}) \subset D^{coH} \otimes B$. We verify that χ^+ defines a coaction on D^{coH} , let $d \in D^{coH}$, then

$$\begin{aligned}
&(\chi^+ \otimes B) \circ \chi^+(d) \\
&= \chi^+(d_{<0>} \nu^{-1}(p(d_{<1>}))) \otimes q(d_{<2>}) \\
&= (d_{<0>} \nu^{-1}(p(d_{<1>})))_{<0>} \nu^{-1}(p((d_{<0>} \nu^{-1}(p(d_{<1>})))_{<1>})) \\
&\quad \otimes q((d_{<0>} \nu^{-1}(p(d_{<1>})))_{<2>}) \otimes q(d_{<2>}) \\
&= d_{<0><0>} \nu^{-1}(p(d_{<1>}))_{<0>} \nu^{-1}(p(d_{<0><1>} \nu^{-1}(p(d_{<1>}))_{<1>})) \\
&\quad \otimes q(d_{<0><2>} \nu^{-1}(p(d_{<1>}))_{<2>}) \otimes q(d_{<2>}) \\
&= d_{<0>} \nu^{-1}(p(d_{<3>}))_{<0>} \nu^{-1}(p(d_{<1>} \nu^{-1}(p(d_{<3>}))_{<1>})) \otimes q(d_{<2>}) \otimes q(d_{<4>}) \\
&= d_{<0>} \nu^{-1}(p(d_{<3>}_2) \nu^{-1}(p(d_{<1>} (1 \times S(p(d_{<3>}_1)))))) \otimes q(d_{<2>}) \otimes q(d_{<4>}) \\
&\quad \text{by (3.2.2)} \\
&= d_{<0>} \nu^{-1}(p(d_{<3>}_2) \nu^{-1}(p(d_{<1>} S(p(d_{<3>}_1)))) \otimes q(d_{<2>}) \otimes q(d_{<4>}) \\
&= d_{<0>} \nu^{-1}(S(p(d_{<3>}_1) p(d_{<3>}_2) \nu^{-1}(p(d_{<1>}))) \otimes q(d_{<2>}) \otimes q(d_{<4>}) \\
&= d_{<0>} \nu^{-1}(p(d_{<1>})) \otimes q(d_{<2>}) \otimes q(d_{<3>}) \\
&= d_{<0>} \nu^{-1}(p(d_{<1>})) \otimes q(d_{<2>1}) \otimes q(d_{<2>2}) \\
&= d_{<0>} \nu^{-1}(p(d_{<1>})) \otimes q(d_{<2>}_1) \otimes q(d_{<2>}_2) \\
&\quad \text{by (3.2.7)} \\
&= (D^{coH} \otimes \Delta_{B \rtimes H}) \circ \chi^+(d)
\end{aligned}$$

Before we show that $\chi^+ : D^{coH} \rightarrow D^{coH} \otimes B$ is left H -linear, note that

$$\begin{aligned}
\chi_r(h \cdot d) &= \chi_r(\nu(h_1) d \nu^{-1}(h_2)) \\
&= (\nu(h_1) d \nu^{-1}(h_2))_{<0>} \otimes (\nu(h_1) d \nu^{-1}(h_2))_{<1>}
\end{aligned}$$

$$\begin{aligned}
&= \nu(h_1)_{\langle 0 \rangle} d_{\langle 0 \rangle} \nu(S(h_2))_{\langle 0 \rangle} \otimes \nu(h_1)_{\langle 1 \rangle} d_{\langle 1 \rangle} \nu(S(h_2))_{\langle 1 \rangle} \\
&= \nu(h_1)_{\langle 0 \rangle} d_{\langle 0 \rangle} \nu(S(h_4)) \otimes (1 \times h_2)_{\langle 1 \rangle} d_{\langle 1 \rangle} (1 \times S(h_3))
\end{aligned} \tag{3.2.4}$$

Moreover, for $d \in D^{coH}$ and $h \in H$, we have

$$\begin{aligned}
\chi^+(h \cdot d) &= \chi^+(\nu(h_1) d \nu^{-1}(h_2)) \\
&= (\nu(h_1) d \nu^{-1}(h_2))_{\langle 0 \rangle} \nu^{-1}(p((\nu(h_1) d \nu^{-1}(h_2))_{\langle 1 \rangle 1})) \\
&\quad \otimes q((\nu(h_1) d \nu^{-1}(h_2))_{\langle 1 \rangle 2}) \\
&= \nu(h_1)_{\langle 0 \rangle} d_{\langle 0 \rangle} \nu(S(h_6)) \nu(S(p((1 \times h_2)_{\langle 1 \rangle} (1 \times S(h_5)))) \\
&\quad \otimes q((1 \times h_3)_{\langle 2 \rangle} (1 \times S(h_4))) \\
&= \nu(h_1)_{\langle 0 \rangle} d_{\langle 0 \rangle} \nu(S(h_5)) \nu(S(h_2 p(d_{\langle 1 \rangle})) S(h_4)) \otimes h_3 \cdot q(d_{\langle 2 \rangle}) \tag{3.1.14} \\
&= \nu(h_1)_{\langle 0 \rangle} d_{\langle 0 \rangle} \nu(S(h_5)) \nu(S^2(h_4)) \nu(p(d_{\langle 1 \rangle})) \nu(S(h_2)) \otimes h_3 \cdot q(d_{\langle 2 \rangle}) \\
&= \nu(h_1)_{\langle 0 \rangle} d_{\langle 0 \rangle} \nu(p(d_{\langle 1 \rangle})) \nu(S(h_2)) \otimes h_3 \cdot q(d_{\langle 2 \rangle}) \\
&= h_1 \cdot (d_{\langle 0 \rangle} \nu(p(d_{\langle 1 \rangle})) \otimes h_2 \cdot q(d_{\langle 2 \rangle})) \\
&= h \cdot \chi^+(d)
\end{aligned}$$

$\chi^+ : D^{coH} \rightarrow D^{coH} \otimes B$ is also left H -colinear, i.e. the diagram

$$\begin{array}{ccc}
D^{coH} & \xrightarrow{\chi^+} & D^{coH} \otimes B \\
\rho_{D^{coH}} \downarrow & & \downarrow \rho_{D^{coH} \otimes B} \\
H \otimes D^{coH} & \xrightarrow{H \otimes \chi^+} & H \otimes D^{coH} \otimes B
\end{array}$$

commutes.

$$\begin{aligned}
&\rho_{D^{coH} \otimes B} \circ \chi^+(d) \\
&= \rho_{D^{coH} \otimes B}(d_{\langle 0 \rangle} \nu^{-1}(q(d_{\langle 1 \rangle})_{(-1)}) \otimes q(d_{\langle 1 \rangle})_{(0)}) \\
&= (d_{\langle 0 \rangle} \nu^{-1}(q(d_{\langle 1 \rangle})_{(-1)}))_{(-1)} q(d_{\langle 1 \rangle})_{(0)(-1)} \otimes (d_{\langle 0 \rangle} \nu^{-1}(q(d_{\langle 1 \rangle})_{(-1)}))_{(0)} \\
&\quad \otimes q(d_{\langle 1 \rangle})_{(0)(0)} \\
&= d_{\langle 0 \rangle (-1)} \nu^{-1}(q(d_{\langle 1 \rangle})_{(-2)})_{(-1)} q(d_{\langle 1 \rangle})_{(-1)} \otimes d_{\langle 0 \rangle (0)} \nu^{-1}(q(d_{\langle 1 \rangle})_{(-1)})_{(0)} \\
&\quad \otimes q(d_{\langle 1 \rangle})_{(0)} \\
&= d_{\langle 0 \rangle (-1)} S(q(d_{\langle 1 \rangle})_{(-2)}) q(d_{\langle 1 \rangle})_{(-1)} \otimes d_{\langle 0 \rangle (0)} \nu^{-1}(q(d_{\langle 1 \rangle})_{(-3)}) \otimes q(d_{\langle 1 \rangle})_{(0)} \\
&\quad \tag{3.2.3} \\
&= d_{\langle 0 \rangle (-1)} \otimes d_{\langle 0 \rangle (0)} \nu^{-1}(q(d_{\langle 1 \rangle})_{(-1)}) \otimes q(d_{\langle 1 \rangle})_{(0)} \\
&= d_{(-1)} \otimes d_{(0) \langle 0 \rangle} \nu^{-1}(q(d_{(0) \langle 1 \rangle})_{(-1)}) \otimes q(d_{(0) \langle 1 \rangle})_{(0)}
\end{aligned}$$

$$= d_{(-1)} \otimes \chi^+(d_{(0)})$$

Lastly, to prove that D^{coH} is a right B -comodule algebra in ${}^H_H\mathcal{YD}$, we have to verify equation (3.1.10). Let $d, d' \in D^{coH}$, then

$$\begin{aligned} & d^{[0]}(d^{[1]}_{(-1)} \cdot d'^{[0]}) \otimes d^{[1]}_{(0)} d'^{[1]} \\ &= d_{<0>} \nu^{-1}(q(d_{<1>}_{(-1)})(q(d_{<1>}_{(0)} \cdot (d'_{<0>} \nu^{-1}(q(d'_{<1>}_{(-1)}))) \\ & \quad \otimes q(d_{<1>}_{(0)(0)} q(d'_{<1>}_{(0)})) \\ &= d_{<0>} \nu^{-1}(q(d_{<1>}_{(-3)}) \nu(q(d_{<1>}_{(-2)})) d'_{<0>} \nu^{-1}(q(d'_{<1>}_{(-1)}) \nu^{-1}(q(d_{<1>}_{(-1)})) \\ & \quad \otimes q(d_{<1>}_{(0)(0)} q(d'_{<1>}_{(0)})) \\ &= d_{<0>} d'_{<0>} \nu^{-1}(q(d_{<1>}_{(-1)} q(d'_{<1>}_{(-1)})) \otimes q(d_{<1>}_{(0)} q(d'_{<1>}_{(0)})) \\ &= d_{<0>} d'_{<0>} \nu^{-1}((q(d_{<1>} q(d'_{<1>}))_{(-1)}) \otimes (q(d_{<1>} q(d'_{<1>}))_{(0)})) \\ &= d_{<0>} d'_{<0>} \nu^{-1}(q(d_{<1>} d'_{<1>}_{(-1)}) \otimes q(d_{<1>} d'_{<1>}_{(0)})) \\ &= (dd')_{<0>} \nu^{-1}(q((dd')_{<1>}_{(-1)}) \otimes q((dd')_{<1>}_{(0)})) \\ &= \chi^+(dd') \end{aligned}$$

which completes the proof. \square

Proposition 3.2.5. *Let D be as above. Then D^{coH} is a B -bicomodule. Hence, D^{coH} is a B -bicomodule algebra in the category ${}^H_H\mathcal{YD}$.*

Proof. By propositions 3.2.2 and 3.2.4, it suffices to prove

$$(\chi^- \otimes B) \circ \chi^+ = (B \otimes \chi^+) \circ \chi^-$$

Let $d \in D^{coH}$, then

$$\begin{aligned} & (\chi^- \otimes B) \circ \chi^+(d) = \chi^-(d^{[0]}) \otimes d^{[1]} \\ &= \chi^-(d_{<0>} \nu^{-1}(q(d_{<1>}_{(-1)})) \otimes q(d_{<1>}_{(0)})) \\ &= q((d_{<0>} \nu^{-1}(q(d_{<1>}_{(-1)}))_{<-1>}) \otimes (d_{<0>} \nu^{-1}(q(d_{<1>}_{(-1)}))_{<0>} \otimes q(d_{<1>}_{(0)})) \\ &= q(d_{<0><-1>} \nu^{-1}(q(d_{<1>}_{(-1)})_{<-1>}) \otimes d_{<0><0>} \nu^{-1}(q(d_{<1>}_{(-1)})_{<0>} \otimes q(d_{<1>}_{(0)})) \\ &= q(d_{<0><-1>} (1 \times S(q(d_{<1>}_{(-1)}))) \otimes d_{<0><0>} \nu^{-1}(q(d_{<1>}_{(-2)}) \otimes q(d_{<1>}_{(0)})) \\ & \quad \text{by (3.2.2)} \\ &= q(d_{<0><-1>}) \otimes d_{<0><0>} \nu^{-1}(q(d_{<1>}_{(-1)}) \otimes q(d_{<1>}_{(0)})) \quad \text{by (3.1.14)} \\ &= q(d_{<-1>}) \otimes d_{<0><0>} \nu^{-1}(q(d_{<0><1>}_{(-1)}) \otimes q(d_{<0><1>}_{(0)})) \\ &= d^{[-1]} \otimes d^{[0]}_{<0>} \nu^{-1}(q(d^{[0]}_{<1>}_{(-1)}) \otimes q(d_{<0><1>}_{(0)})) \\ &= d^{[-1]} \otimes \chi^+(d^{[0]}) = (B \otimes \chi^+) \circ \chi^-(d) \end{aligned}$$

\square

Let us summarize what we have so far. If D is a $B \rtimes H$ -bi-Galois object for which there exists a $B \rtimes H$ -bilinear algebra map $\nu : H \rightarrow D$, then $D^{coH} \in {}^H_H\mathcal{YD}$ and $D \cong D^{coH} \# H$ as H -bicomodule algebras. Now, since D^{coH} is a B -bicomodule algebra in ${}^H_H\mathcal{YD}$ (Proposition 3.2.5), $D^{coH} \# H$ is again a $B \rtimes H$ -bicomodule algebra, by Proposition 3.1.2. We prove that $D \cong D^{coH} \# H$ as $B \rtimes H$ -bicomodule algebras.

Proposition 3.2.6. *The isomorphism $\omega : D^{coH} \# H \rightarrow D$ is $B \rtimes H$ -bilinear.*

Proof. Recall $\omega(d\#h) = d\nu(h)$ for $d \in D^{coH}$ and $h \in H$. We have

$$\begin{aligned}
(id \otimes \omega) \circ \chi_l(d\#h) &= d^{[-1]} \times d^{[0]}_{(-1)} h_1 \otimes \omega(d^{[0]}_{(0)} \# h_2) \\
&= q(d_{<-1>}) \times d_{<0>(-1)} h_1 \otimes d_{<0>(0)} \nu(h_2) \\
&= q(d_{<-1>}) \times p(d_{<0><-1>}) h_1 \otimes d_{<0><0>} \nu(h_2) \\
&= q(d_{<-1>1}) \times p(d_{<-1>2}) h_1 \otimes d_{<0>} \nu(h_2) \\
&= d_{<-1>} (1 \times h_1) \otimes d_{<0>} \nu(h_2) && \text{by (3.1.12)} \\
&= d_{<-1>} \nu(h)_{<-1>} \otimes d_{<0>} \nu(h)_{<0>} && (\nu \text{ left } B \rtimes H\text{-colinear}) \\
&= (d\nu(h))_{<-1>} \otimes (d\nu(h))_{<0>} = \chi_l \circ \omega(d\#h)
\end{aligned}$$

and

$$\begin{aligned}
(\omega \otimes id) \circ \chi_r(d\#h) &= \omega(d^{[0]} \# d^{[1]}_{(-1)} h_1) \otimes d^{[1]}_{(0)} \times h_2 \\
&= d^{[0]} \nu(d^{[1]}_{(-1)} h_1) \otimes d^{[1]}_{(0)} \times h_2 \\
&= d_{<0>} \nu^{-1}(q(d_{<1>})_{(-1)}) \nu(q(d_{<1>})_{(0)(-1)} h_1) \otimes q(d_{<1>})_{(0)(0)} \times h_2 \\
&= d_{<0>} \nu(S(q(d_{<1>})_{(-1)1})) \nu(q(d_{<1>})_{(-1)2}) \nu(h_1) \otimes q(d_{<1>})_{(0)} \times h_2 \\
&= d_{<0>} \nu(h_1) \otimes q(d_{<1>}) \times h_2 \\
&= d_{<0>} \nu(h_1) \otimes d_{<1>} (1 \times h_2) && \text{by (3.2.7)} \\
&= d_{<0>} \nu(h)_{<0>} \otimes d_{<1>} \nu(h)_{<1>} && (\nu \text{ right } B \rtimes H\text{-colinear}) \\
&= (d\nu(h))_{<0>} \otimes (d\nu(h))_{<1>} = \chi_r \circ \omega(d\#h)
\end{aligned}$$

□

To prove that D^{coH} is a preimage of D under ξ , all that remains to show is that D^{coH} is B -bi-Galois.

Lemma 3.2.7. *Let D be as above. D^{coH} is a right B -Galois object in ${}^H_H\mathcal{YD}$.*

Proof. Take $d \in (D^{coH})^{coB}$. As $d \in D^{coB}$, we have

$$\begin{aligned}
\chi^+(d) &= d_{<0>} \nu(S(q(d_{<1>})_{(-1)})) \otimes q(d_{<1>})_{(0)} \\
&= d \otimes 1_B
\end{aligned}$$

On the other hand, since $d \in D^{coH}$ and by Remark 3.2.3, we may assume $\chi_r(d) \in D \otimes B \times 1$. Then

$$\begin{aligned} d_{\langle 0 \rangle} \otimes d_{\langle 1 \rangle} &= d_{\langle 0 \rangle} \otimes q(d_{\langle 1 \rangle}) \times 1_H \\ &= d_{\langle 0 \rangle} \nu(S(q(d_{\langle 1 \rangle})_{(-2)})) \nu(q(d_{\langle 1 \rangle})_{(-1)}) \otimes q(d_{\langle 1 \rangle})_{(0)} \\ &= d_{\langle 0 \rangle} \nu(1_{B(-1)}) \otimes 1_{B(0)} \\ &= d \otimes 1_B \times 1_H \end{aligned}$$

Thus $d \in D^{co(B \rtimes H)} = k$. This proves $(D^{coH})^{coB} = k$. Next we have to show that the right canonical morphism can_+

$$\begin{aligned} can_+ : D^{coH} \otimes D^{coH} &\rightarrow D^{coH} \otimes B, \\ can_+(c \otimes d) &= cd^{[0]} \otimes d^{[1]} \\ &= cd_{\langle 0 \rangle} \nu^{-1}(q(d_{\langle 1 \rangle})_{(-1)}) \otimes q(d_{\langle 1 \rangle})_{(0)} \end{aligned}$$

is bijective. As D is a right $B \rtimes H$ -Galois object, say with right canonical morphism can_r^D , we can introduce the following notation

$$(can_r^D)^{-1}(1_D \otimes b \times h) = \sum_i x_i(b \times h) \otimes y_i(b \times h) \in D \otimes D$$

for $b \in B$ and $h \in H$, similarly as in Section 3.1. We use lower case x and y here to denote a difference with the notation for braided B -Galois objects. Then by definition

$$x_i(b \times h) y_i(b \times h)_{\langle 0 \rangle} \otimes y_i(b \times h)_{\langle 1 \rangle} = 1_D \otimes (b \times h) \quad (3.2.8)$$

$$d_{\langle 0 \rangle} x_i(d_{\langle 1 \rangle}) \otimes y_i(d_{\langle 1 \rangle}) = 1_D \otimes d \quad (3.2.9)$$

for $d \in D$, $b \in B$ and $h \in H$. We can define the inverse of can_+ as follows

$$\begin{aligned} (can_+)^{-1} : D^{coH} \otimes B &\rightarrow D^{coH} \otimes D^{coH}, \\ (can_+)^{-1}(d \otimes b) &= d \nu(b_{(-1)}) x_i(b_{(0)} \times 1) \otimes y_i(b_{(0)} \times 1) \end{aligned}$$

We first verify that $(can_+)^{-1}(D^{coH} \otimes B) \subset D^{coH} \otimes D^{coH}$. Let $b \in B$.

$$\begin{aligned} &d \nu(b_{(-1)}) x_i(b_{(0)} \times 1) \otimes \rho^r(y_i(b_{(0)} \times 1)) \\ &= d \nu(b_{(-1)}) x_i(b_{(0)} \times 1) \otimes y_i(b_{(0)} \times 1)_{(0)} \otimes y_i(b_{(0)} \times 1)_{(1)} \\ &= d \nu(b_{(-1)}) x_i(b_{(0)} \times 1) \otimes y_i(b_{(0)} \times 1)_{\langle 0 \rangle} \otimes p(y_i(b_{(0)} \times 1)_{\langle 1 \rangle}) \\ &= d \nu(b_{(-1)}) x_i((b_{(0)} \times 1)_1) \otimes y_i((b_{(0)} \times 1)_1) \otimes p((b_{(0)} \times 1)_2) \quad \text{by (1.4.7)} \\ &= d \nu(b_{(-1)}) x_i(b_{(0)1} \times b_{(0)2(-1)}) \otimes y_i(b_{(0)1} \times b_{(0)2(-1)}) \otimes p(b_{(0)2(0)} \times 1) \\ &= d \nu(b_{(-1)}) x_i(b_{(0)} \times 1) \otimes y_i(b_{(0)} \times 1) \otimes 1 \end{aligned}$$

thus $(can_+)^{-1}(d \otimes b) \in D \otimes D^{coH}$, but also

$$\begin{aligned}
& \rho^r(d\nu(b_{(-1)})x_i(b_{(0)} \times 1)) \otimes y_i(b_{(0)} \times 1) \\
&= d_{(0)}\nu(b_{(-1)})_{(0)}x_i(b_{(0)} \times 1)_{(0)} \otimes d_{(1)}\nu(b_{(-1)})_{(1)}x_i(b_{(0)} \times 1)_{(1)} \otimes y_i(b_{(0)} \times 1) \\
&= d\nu(b_{(-2)})x_i(b_{(0)} \times 1)_{<0>} \otimes b_{(-1)}p(x_i(b_{(0)} \times 1)_{<1>}) \otimes y_i(b_{(0)} \times 1) \\
&= d\nu(b_{(-2)})x_i((b_{(0)} \times 1)_2) \otimes b_{(-1)}p(S(x_i(b_{(0)} \times 1)_1)) \otimes y_i((b_{(0)} \times 1)_2) \quad \text{by (1.4.8)} \\
&= d\nu(b_{(-2)})x_i(b_{(0)2(0)} \times 1) \otimes b_{(-1)}p(S(b_{(0)1} \times b_{(0)2(-1)})) \otimes y_i(b_{(0)2(0)} \times 1) \\
&= d\nu(b_{(-2)})x_i(b_{(0)2(0)} \times 1) \otimes b_{(-1)}\varepsilon_B(b_{(0)1})S_H(b_{(0)2(-1)}) \otimes y_i(b_{(0)2(0)} \times 1) \\
& \hspace{15em} \text{since } p \circ S = S_H \circ p \\
&= d\nu(b_{(-3)})x_i(b_{(0)} \times 1) \otimes b_{(-2)}S_H(b_{(-1)}) \otimes y_i(b_{(0)} \times 1) \\
&= d\nu(b_{(-1)})x_i(b_{(0)} \times 1) \otimes 1 \otimes y_i(b_{(0)} \times 1)
\end{aligned}$$

so $(can_+)^{-1}(d \otimes b) \in D^{coH} \otimes D^{coH}$. Finally

$$\begin{aligned}
can_+ \circ (can_+)^{-1}(d \otimes b) &= can_+(d\nu(b_{(-1)})x_i(b_{(0)} \times 1) \otimes y_i(b_{(0)} \times 1)) \\
&= d\nu(b_{(-1)})x_i(b_{(0)} \times 1)y_i(b_{(0)} \times 1)^{[0]} \otimes y_i(b_{(0)} \times 1)^{[1]} \\
&= d\nu(b_{(-1)})x_i(b_{(0)} \times 1)y_i(b_{(0)} \times 1)_{<0>} \nu^{-1}(q(y_i(b_{(0)} \times 1)_{<1>}_{(-1)})) \\
& \hspace{10em} \otimes q(y_i(b_{(0)} \times 1)_{<1>}_{(0)}) \\
&= d\nu(b_{(-1)})\nu^{-1}(q(b_{(0)} \times 1)_{(-1)}) \otimes q(b_{(0)} \times 1)_{(0)} \quad \text{by (3.2.8)} \\
&= d\nu(b_{(-2)})\nu^{-1}(b_{(-1)}) \otimes b_{(0)} \\
&= d \otimes b
\end{aligned}$$

and

$$\begin{aligned}
(can_+)^{-1} \circ can_+(c \otimes d) &= (can_+)^{-1}(cd_{<0>} \nu^{-1}(q(d_{<1>}_{(-1)})) \otimes q(d_{<1>}_{(0)})) \\
&= cd_{<0>} \nu^{-1}(q(d_{<1>}_{(-1)})\nu(q(d_{<1>}_{(0)(1)}))x_i(q(d_{<1>}_{(0)} \times 1)) \otimes \\
& \hspace{10em} y_i(q(d_{<1>}_{(0)(0)} \times 1)) \\
&= cd_{<0>}x_i(q(d_{<1>} \times 1)) \otimes y_i(q(d_{<1>} \times 1)) \\
&= cd_{<0>}x_i(d_{<1>}) \otimes y_i(d_{<1>}) \quad \text{by Remark 3.2.3} \\
&= c \otimes d \quad \text{by (3.2.9)}
\end{aligned}$$

This completes the proof. \square

Lemma 3.2.8. *Let D be as above. D^{coH} is a left B -Galois object in ${}^H_H\mathcal{YD}$.*

Proof. First, let us show ${}^{coB}(D^{coH}) = k$. Take $d \in {}^{coB}(D^{coH})$. Then

$$\begin{aligned}
\chi^-(d) &= d^{[-1]} \otimes d^{[0]} = q(d_{<-1>}) \otimes d_{<0>} \\
&= 1_B \otimes d \quad (3.2.10)
\end{aligned}$$

As also $d \in D^{coH}$, we have $\phi^{-1}(1_H \otimes d) = d_{(0)} \otimes S^{-1}(d_{(-1)}) \in D^{coH} \otimes H$. Furthermore, by Proposition 3.2.6, $D \cong D^{coH} \# H$ as $B \rtimes H$ -bicomodule algebras. In particular we have

$${}^{co(B \rtimes H)}(D^{coH} \# H) \cong {}^{co(B \rtimes H)}(D) = k$$

Now

$$\begin{aligned} & \chi_l(d_{(0)} \# S^{-1}(d_{(-1)})) \\ &= d_{(0)}^{[-1]} \times d_{(0)(-1)}^{[0]} S^{-1}(d_{(-1)})_1 \otimes d_{(0)(0)}^{[0]} \# S^{-1}(d_{(-1)})_2 \\ &= d_{(0)(-1)}^{[-1]} \times d_{(0)(-1)}^{[0]} S^{-1}(d_{(-1)}^{[-1]} d_{(-1)}^{[0]})_1 \\ & \quad \otimes d_{(0)(0)}^{[0]} \# S^{-1}(d_{(-1)}^{[-1]} d_{(-1)}^{[0]})_2 && \text{by (3.1.7)} \\ &= 1_B \times d_{(0)(-1)} S^{-1}(d_{(-1)})_1 \otimes d_{(0)(0)} \# S^{-1}(d_{(-1)})_2 && \text{by (3.2.10)} \\ &= 1_B \times d_{(-1)} S^{-1}(d_{(-2)}) \otimes d_{(0)} \# S^{-1}(d_{(-3)}) \\ &= 1_B \times 1_H \otimes d_{(0)} \# S^{-1}(d_{(-1)}) \end{aligned}$$

Hence $d_{(0)} \# S^{-1}(d_{(-1)}) \in {}^{co(B \rtimes H)}(D^{coH} \# H) = k$, say $d_{(0)} \# S^{-1}(d_{(-1)}) = \lambda(1_B \# 1_H)$. Applying $B \otimes \varepsilon_H$, we obtain $d = \lambda 1_B \in k 1_B$. Thus ${}^{coB}(D^{coH}) = k$.

The next step is to show that the left canonical morphism

$$\begin{aligned} can_- : D^{coH} \otimes D^{coH} &\rightarrow B \otimes D^{coH} : c \otimes d \mapsto c^{[-1]} \otimes c^{[0]} d \\ &= q(c_{<-1>} \otimes c_{<0>} d) \end{aligned}$$

is bijective. Consider the left canonical map of D

$$can_l^D : D \otimes D \rightarrow B \rtimes H \otimes D : c \otimes d \mapsto c_{<-1>} \otimes c_{<0>} d$$

and define

$$(can_l^D)^{-1}(b \times h \otimes 1_D) = \sum_i u_i(b \times h) \otimes v_i(b \times h) \in D \otimes D$$

for $b \in B$ and $h \in H$. By definition we have

$$u_i(b \times h)_{<-1>} \otimes u_i(b \times h)_{<0>} v_i(b \times h) = (b \times h) \otimes 1_D \quad (3.2.11)$$

$$u_i(d_{<-1>}) \otimes v_i(d_{<-1>} d_{<0>}) = d \otimes 1_D \quad (3.2.12)$$

for any $b \in B$, $h \in H$. Again, the use of lower case u and v is to keep a difference to the notation we use for (braided) B -Galois objects, for which we use capital U and V , as in (3.1.20).

Moreover, one can easily verify that can_l^D is right H -colinear, as a consequence we have

$$\begin{aligned} u_i(b \times h)_{(0)} \otimes v_i(b \times h)_{(0)} \otimes u_i(b \times h)_{(1)} v_i(b \times h)_{(1)} \\ = u_i(b \times h) \otimes v_i(b \times h) \otimes 1_H \end{aligned} \quad (3.2.13)$$

It suffices to define $U_i(b) \otimes V_i(b) \in D^{coH} \otimes D^{coH}$ for which

$$U_i(b)^{[-1]} \otimes U_i(b)^{[0]} V_i(b) = b \otimes 1_D \quad (3.2.14)$$

$$U_i(d^{[-1]}) \otimes V_i(d^{[-1]}) d^{[0]} = d \otimes 1_D \quad (3.2.15)$$

for $b \in B$ and $d \in D^{coH}$. Indeed, these equations exactly say that we can define the inverse of can_- as follows

$$(can_-)^{-1}(b \otimes d) = U_i(b) \otimes V_i(b)d$$

Take $b \in B$, then, as $D \cong D^{coH} \# H$, the element

$$u_i(b \times 1) \otimes v_i(b \times 1) \in D \otimes D$$

is isomorphic to

$$\begin{aligned} u_i(b \times 1)_{(0)} \nu^{-1}(u_i(b \times 1)_{(1)}) \# u_i(b \times 1)_{(2)} \\ \otimes v_i(b \times 1)_{(0)} \nu^{-1}(v_i(b \times 1)_{(1)}) \# v_i(b \times 1)_{(2)} \\ \in (D^{coH} \# H) \otimes (D^{coH} \# H) \end{aligned}$$

Apply ε_H on the last leg to obtain

$$\begin{aligned} u_i(b \times 1)_{(0)} \nu^{-1}(u_i(b \times 1)_{(1)}) \# u_i(b \times 1)_{(2)} \otimes v_i(b \times 1)_{(0)} \nu^{-1}(v_i(b \times 1)_{(1)}) \\ \in (D^{coH} \# H) \otimes D^{coH} \end{aligned}$$

We can now define $U_i(b) \otimes V_i(b)$ for $b \in B$ as

$$\begin{aligned} U_i(b) \otimes V_i(b) \\ = u_i(b \times 1)_{(0)} \nu^{-1}(u_i(b \times 1)_{(1)}) \\ \otimes u_i(b \times 1)_{(2)} \cdot (v_i(b \times 1)_{(0)} \nu^{-1}(v_i(b \times 1)_{(1)})) \end{aligned}$$

which is by its definition an element in $D^{coH} \otimes D^{coH}$. We have to prove (3.2.14) and

(3.2.15). Let $b \in B$, then

$$\begin{aligned}
& U_i(b)^{[-1]} \otimes U_i(b)^{[0]} V_i(b) \\
&= q(U_i(b)_{\langle -1 \rangle}) \otimes U_i(b)_{\langle 0 \rangle} V_i(b) \\
&= q((u_i(b \times 1)_{(0)} \nu^{-1}(u_i(b \times 1)_{(1)}))_{\langle -1 \rangle}) \\
&\quad \otimes (u_i(b \times 1)_{(0)} \nu^{-1}(u_i(b \times 1)_{(1)}))_{\langle 0 \rangle} \\
&\quad (u_i(b \times 1)_{(2)} \cdot (v_i(b \times 1)_{(0)} \nu^{-1}(v_i(b \times 1)_{(1)}))) \\
&= q(u_i(b \times 1)_{(0) \langle -1 \rangle} \nu^{-1}(u_i(b \times 1)_{(1) \langle -1 \rangle})) \\
&\quad \otimes u_i(b \times 1)_{(0) \langle 0 \rangle} \nu^{-1}(u_i(b \times 1)_{(1) \langle 0 \rangle}) \\
&\quad (u_i(b \times 1)_{(2)} \cdot (v_i(b \times 1)_{(0)} \nu^{-1}(v_i(b \times 1)_{(1)}))) \\
&= q(u_i(b \times 1)_{(0) \langle -1 \rangle} (1 \times S(u_i(b \times 1)_{(2)}))) \\
&\quad \otimes u_i(b \times 1)_{(0) \langle 0 \rangle} \nu^{-1}(u_i(b \times 1)_{(1)}) \\
&\quad (u_i(b \times 1)_{(3)} \cdot (v_i(b \times 1)_{(0)} \nu^{-1}(v_i(b \times 1)_{(1)}))) \\
&= q(u_i(b \times 1)_{(0) \langle -1 \rangle}) \\
&\quad \otimes u_i(b \times 1)_{(0) \langle 0 \rangle} \nu^{-1}(u_i(b \times 1)_{(1)}) \\
&\quad (u_i(b \times 1)_{(2)} \cdot (v_i(b \times 1)_{(0)} \nu^{-1}(v_i(b \times 1)_{(1)}))) \\
&= q(u_i(b \times 1)_{(0) \langle -1 \rangle}) \\
&\quad \otimes u_i(b \times 1)_{(0) \langle 0 \rangle} v_i(b \times 1)_{(0)} \nu^{-1}(v_i(b \times 1)_{(1)}) \nu^{-1}(u_i(b \times 1)_{(1)}) \\
&= q(u_i(b \times 1)_{\langle -1 \rangle}) \\
&\quad \otimes u_i(b \times 1)_{\langle 0 \rangle (0)} v_i(b \times 1)_{(0)} \nu^{-1}(v_i(b \times 1)_{(1)}) \nu^{-1}(u_i(b \times 1)_{\langle 0 \rangle (1)}) \\
&= u_i(b \times 1)^{[-1]} \\
&\quad \otimes u_i(b \times 1)_{(0)}^{[0]} v_i(b \times 1)_{(0)} \nu^{-1}(v_i(b \times 1)_{(1)}) \nu^{-1}(u_i(b \times 1)_{(1)})^{[0]} \\
&= b \otimes 1_D
\end{aligned}$$

where the last equality follows from the following observation.

By (3.2.11) we have

$$u_i(b \times 1)_{\langle -1 \rangle} \otimes u_i(b \times 1)_{\langle 0 \rangle} v_i(b \times 1) = (b \times 1) \otimes 1_D$$

for any $b \in B$, which belongs to $B \rtimes H \otimes D$. Applying the isomorphism $\omega : D \rightarrow D^{coH} \# H$, we get

$$\begin{aligned}
& u_i(b \times 1)_{\langle -1 \rangle} \\
&\quad \otimes u_i(b \times 1)_{\langle 0 \rangle (0)} v_i(b \times 1)_{(0)} \nu^{-1}(u_i(b \times 1)_{\langle 0 \rangle (1)} v_i(b \times 1)_{(1)}) \\
&\quad \# u_i(b \times 1)_{\langle 0 \rangle (2)} v_i(b \times 1)_{(2)} \\
&= b \times 1 \otimes 1_D \# 1 \in B \rtimes H \otimes D^{coH} \# H
\end{aligned}$$

or after applying $B \rtimes H \otimes D^{coH} \otimes \varepsilon_H$

$$\begin{aligned}
& u_i(b \times 1)_{<-1>} \\
& \quad \otimes u_i(b \times 1)_{<0>(0)} v_i(b \times 1)_{(0)} \nu^{-1}(v_i(b \times 1)_{(1)}) \nu^{-1}(u_i(b \times 1)_{<0>(1)}) \\
& = b \times 1 \otimes 1_D \\
& \in B \rtimes H \otimes D^{coH}
\end{aligned}$$

Finally, by applying $q \otimes D^{coH}$ we arrive at

$$\begin{aligned}
& u_i(b \times 1)^{[-1]} \otimes \\
& \quad u_i(b \times 1)^{[0]}_{(0)} v_i(b \times 1)_{(0)} \nu^{-1}(v_i(b \times 1)_{(1)}) \nu^{-1}(u_i(b \times 1)^{[0]}_{(1)}) \\
& = b \otimes 1_D
\end{aligned}$$

This proves (3.2.14), or $can_- \circ (can_-)^{-1} = 1$. It remains to show (3.2.15). First note that

$$u_i(b \times 1) \nu(h_1) \otimes \nu(S(h_2)) v_i(b \times 1) = u_i(b \times h) \otimes v_i(b \times h) \quad (3.2.16)$$

for $b \in B$ and $h \in H$, which can be proven by applying the isomorphism can_l^D on both sides. Indeed

$$\begin{aligned}
& can_l^D(u_i(b \times 1) \nu(h_1) \otimes \nu(S(h_2)) v_i(b \times 1)) \\
& = u_i(b \times 1)_{<-1>} \nu(h_1)_{<-1>} \otimes u_i(b \times 1)_{<0>} \nu(h_1)_{<0>} \nu(S(h_2)) v_i(b \times 1) \\
& = u_i(b \times 1)_{<-1>} (1 \times h_1) \otimes u_i(b \times 1)_{<0>} \nu(h_2) \nu(S(h_3)) v_i(b \times 1) \\
& = u_i(b \times 1)_{<-1>} (1 \times h) \otimes u_i(b \times 1)_{<0>} v_i(b \times 1) \\
& = (b \times 1) (1 \times h) \otimes 1_D \quad \text{by (3.2.12)} \\
& = (b \times h) \otimes 1_D \\
& = u_i(b \times h)_{<-1>} \otimes u_i(b \times h)_{<0>} v_i(b \times 1) \quad \text{by (3.2.12)} \\
& = can_l^D(u_i(b \times h) \otimes v_i(b \times h))
\end{aligned}$$

which proves (3.2.16). Now, to prove $(can_-)^{-1} \circ can_- = 1$, take $d \in D^{coH}$. Say $\chi_l(d) = \sum_j b_j \times h_j \otimes d_j \in B \rtimes H \otimes D$. Then

$$\begin{aligned}
& U_i(d^{[-1]}) \otimes V_i(d^{[-1]}) d^{[0]} \\
& = U_i(q(d_{<-1>})) \otimes V_i(q(d_{<-1>})) d_{<0>} \\
& = U_i(b_j) \otimes V_i(b_j) \varepsilon(h_j) d_j
\end{aligned}$$

$$\begin{aligned}
&= u_i(b_j \times 1)_{(0)} \nu^{-1}(u_i(b_j \times 1)_{(1)}) \\
&\quad \otimes u_i(b_j \times 1)_{(2)} \cdot (v_i(b_j \times 1)_{(0)} \nu^{-1}(v_i(b_j \times 1)_{(1)})) \varepsilon(h_j) d_j \\
&= u_i(b_j \times 1)_{(0)} \nu^{-1}(u_i(b_j \times 1)_{(1)}) \\
&\quad \otimes \nu(u_i(b_j \times 1)_{(2)}) v_i(b_j \times 1)_{(0)} \nu^{-1}(v_i(b_j \times 1)_{(1)}) \nu^{-1}(u_i(b_j \times 1)_{(3)}) \varepsilon(h_j) d_j \\
&= u_i(b_j \times 1)_{(0)} \nu^{-1}(u_i(b_j \times 1)_{(1)}) \otimes \nu(u_i(b_j \times 1)_{(2)}) v_i(b_j \times 1) \varepsilon(h_j) d_j
\end{aligned}$$

where the last equation is a result of (3.2.13). Now we conclude the proof by showing that

$$\begin{aligned}
&u_i(b_j \times 1)_{(0)} \nu^{-1}(u_i(b_j \times 1)_{(1)}) \otimes \nu(u_i(b_j \times 1)_{(2)}) v_i(b_j \times 1) \varepsilon(h_j) d_j \\
&= d \otimes 1_D
\end{aligned}$$

Indeed, by (3.2.12), we have

$$u_i(b_j \times h_j) \otimes v_i(b_j \times h_j) d_j = d \otimes 1_D$$

or in view of (3.2.16)

$$u_i(b_j \times 1) \nu((h_j)_1) \otimes \nu^{-1}((h_j)_2) v_i(b_j \times 1) d_j = d \otimes 1_D$$

which belongs to $D \otimes D$. Apply $\omega \otimes D$ where ω is the isomorphism $D \rightarrow D^{coH} \# H$ as before. We obtain

$$\begin{aligned}
&d \# 1_H \otimes 1_D \\
&= u_i(b_j \times 1)_{(0)} \nu((h_j)_1)_{(0)} \nu^{-1}(u_i(b_j \times 1)_{(1)} \nu((h_j)_1)_{(1)}) \\
&\quad \# u_i(b_j \times 1)_{(2)} \nu((h_j)_1)_{(2)} \otimes \nu^{-1}((h_j)_2) v_i(b_j \times 1) d_j \\
&= u_i(b_j \times 1)_{(0)} \nu((h_j)_1) \nu^{-1}(u_i(b_j \times 1)_{(1)} (h_j)_2) \\
&\quad \# u_i(b_j \times 1)_{(2)} (h_j)_3 \otimes \nu^{-1}((h_j)_4) v_i(b_j \times 1) d_j \\
&= u_i(b_j \times 1)_{(0)} \nu^{-1}(u_i(b_j \times 1)_{(1)}) \\
&\quad \# u_i(b_j \times 1)_{(2)} (h_j)_1 \otimes \nu^{-1}((h_j)_2) v_i(b_j \times 1) d_j
\end{aligned}$$

where the second equation is obtained by applying (3.2.13). Finally apply $D \otimes \nabla_D \circ D \otimes \nu \otimes D$ to obtain

$$\begin{aligned}
&d \otimes 1_D \\
&= u_i(b_j \times 1)_{(0)} \nu^{-1}(u_i(b_j \times 1)_{(1)}) \\
&\quad \otimes \nu(u_i(b_j \times 1)_{(2)} (h_j)_1) \nu^{-1}((h_j)_2) v_i(b_j \times 1) d_j \\
&= u_i(b_j \times 1)_{(0)} \nu^{-1}(u_i(b_j \times 1)_{(1)}) \otimes \nu(u_i(b_j \times 1)_{(2)}) \varepsilon(h_j) v_i(b_j \times 1) d_j
\end{aligned}$$

which finishes the proof. \square

By combining all the above results, we have proven the following theorem.

Theorem 3.2.9. *The image of the morphism ξ is the subgroup of $\text{BiGal}(B \rtimes H)$ of isomorphism classes represented by those $B \rtimes H$ -bi-Galois objects D for which there exists a $B \rtimes H$ -bilinear algebra morphism $H \rightarrow D$.*

$B \rtimes H$ is an ordinary k -Hopf algebra, hence Lemma 3.2.1 provides us with a general structure theorem for bicomodule algebras over $B \rtimes H$. However, combining Lemma 3.2.1 and Propositions 3.1.2, 3.2.5 and 3.2.6, we obtain a second structure theorem for bicomodule algebras over the Radford biproduct, which can be seen as an independent result on its own.

Theorem 3.2.10. *Let H be an arbitrary k -Hopf algebra and B a Hopf algebra in ${}^H_H\mathcal{YD}$. If D is a $B \rtimes H$ -bicomodule algebra with the property that there exists a $B \rtimes H$ -bilinear algebra map $\nu : H \rightarrow D$, then D is isomorphic (as a $B \rtimes H$ -bicomodule algebra) to the smash product $A \# H$, where $A = D^{\text{co}H}$. Here the multiplication on A is the restriction of the multiplication on D and A is a B -bicomodule algebra in ${}^H_H\mathcal{YD}$.*

3.3 Extending (co-outer) automorphisms

The map

$$\zeta_o : \text{Aut}_{\text{Hopf}}(B) \longrightarrow \text{Aut}_{\text{Hopf}}(B \rtimes H), \quad \alpha \longmapsto \bar{\alpha} = \alpha \otimes H$$

is a group morphism, the prove is completely similar to the computation showing that the morphism ξ from Theorem 3.1.8 is well-defined.

Lemma 3.3.1. *Let $\mu : B \rightarrow k$ be a morphism in ${}^H_H\mathcal{YD}$. Then*

$$ad(\mu) \otimes H = ad(\mu \otimes \varepsilon)$$

Proof. By H -(co)linearity of μ , we have

$$\begin{aligned} \mu(h \cdot b) &= \varepsilon(h)\mu(b) \\ b_{(-1)}\mu(b_{(0)}) &= 1_H\mu(b) \end{aligned}$$

Using this we see

$$\begin{aligned} ad(\mu \otimes \varepsilon)(b \times h) &= ((\mu \otimes \varepsilon) \circ S_{B \rtimes H} * id * (\mu \otimes \varepsilon))(b \times h) \\ &= (\mu \otimes \varepsilon)(S_{B \rtimes H}(b_1 \times b_{2(-1)}b_{3(-2)}h_1))(b_{2(0)} \times b_{3(-1)}h_2)(\mu \otimes \varepsilon)(b_{3(0)} \times h_3) \\ &= \mu(S_H(b_{1(-1)}b_{2(-1)}b_{3(-2)}h_1) \cdot S_B(b_{1(0)}))(b_{2(0)} \times b_{3(-1)}h_2)\mu(b_{3(0)}) \quad \text{by (3.1.15)} \\ &= \mu(S_B(b_1))(b_2 \times b_{3(-1)}h)\mu(b_{3(0)}) \\ &= \mu(S_B(b_1))(b_2 \times h)\mu(b_3) \\ &= ad(\mu)(b) \times h \end{aligned}$$

for $b \in B$ and $h \in H$. □

Theorem 3.3.2. *The group morphism $Aut_{Hopf}(B) \longrightarrow Aut_{Hopf}(B \rtimes H)$ above induces a group homomorphism*

$$\begin{aligned} \zeta : CoOut(B) &\longrightarrow CoOut(B \rtimes H) \\ [\alpha] &\longmapsto [\bar{\alpha} = \alpha \otimes H] \end{aligned}$$

Proof. Suppose $\alpha = ad(\phi)$ for some algebra map $\phi : B \rightarrow k$ in $\frac{H}{H}\mathcal{YD}$. Then $\bar{\alpha} = ad(\phi) \otimes H = ad(\phi \otimes \varepsilon)$, by the preceding lemma. To show that ζ is well-defined, it now suffices to verify that $\phi \otimes \varepsilon : B \rtimes H \rightarrow k$ is an algebra morphism. Let $b, c \in B$ and $h, g \in H$, then

$$\begin{aligned} &(\phi \otimes \varepsilon)((b \times h)(c \times g)) \\ &= (\phi \otimes \varepsilon)(b(h_1 \cdot c) \times h_2 g) \\ &= \phi(b(h \cdot c))\varepsilon(g) \\ &= \phi(b)\phi((h \cdot c))\varepsilon(g) \\ &= \phi(b)\varepsilon(h)\phi(c)\varepsilon(g) \\ &= (\phi \otimes \varepsilon)(b \times h)(\phi \otimes \varepsilon)(c \times g) \end{aligned}$$

□

Corollary 2.2.10, Theorem 3.1.8 and Theorem 3.3.2 fit nicely into the following commutative diagram.

$$\begin{array}{ccc} CoOut(B) & \xrightarrow{i} & BiGal(B) \\ \downarrow \zeta & & \downarrow \xi \\ CoOut(B \rtimes H) & \xrightarrow{i'} & BiGal(B \rtimes H) \end{array} \quad (3.3.1)$$

Indeed, ${}^\alpha B \# H = \bar{\alpha}(B \rtimes H) = B \# H$ as algebras. The right $B \rtimes H$ -coaction is in both case equal to $\Delta_{B \rtimes H}$. Lastly, ${}^\alpha B \# H$ has left $B \rtimes H$ -comodule structure given by

$$\begin{aligned} \chi_l(b \# h) &= (b^{[-1]} \times b^{[0]}_{(-1)} h_1) \otimes (b^{[0]}_{(0)} \# h_2) \\ &= (\alpha(b_1) \times b_{2(-1)} h_1) \otimes (b_{2(0)} \# h_2) \\ &= (\bar{\alpha} \otimes B \rtimes H) \circ \Delta_{B \rtimes H}(b \# h) \end{aligned}$$

which equals the left $B \rtimes H$ -coaction of $\bar{\alpha}(B \rtimes H)$. Thus $\xi \circ i([\alpha]) = [{}^\alpha B \# H] = [\bar{\alpha}(B \rtimes H)] = i' \circ \zeta([\alpha])$.

We shall use this diagram to compute the kernel of ξ .

3.4 The kernel of ξ

The next goal is to compute the kernel of ξ . Assume (A, χ^-, χ^+) is a B -bi-Galois object such that there exists an isomorphism $\varphi : A\#H \rightarrow B \rtimes H$ of $B \rtimes H$ -bicomodule algebras. By applying the functors P_l and P_r we have that φ is also H -bilinear. Then

$$A \cong A\#1 = (A\#H)^{coH} \xrightarrow{\sim} (B \rtimes H)^{coH} = B\#1 \cong B$$

I.e. φ restricts to an algebra isomorphism from A to B . For the H -linearity of $\varphi|_A$ we need the following lemma.

Lemma 3.4.1. *We have*

$$\begin{aligned} \varphi(1\#h_1) \otimes \varphi(1\#S(h_2)) &= (1 \times h_1) \otimes (1 \times S(h_2)) \\ &\in B \rtimes H \otimes B \rtimes H \end{aligned} \quad (3.4.1)$$

for $h \in H$.

Proof. $B \rtimes H$ is left $B \rtimes H$ -Galois with

$$\begin{aligned} can_l : B \rtimes H \otimes B \rtimes H &\rightarrow B \rtimes H \otimes B \rtimes H, \\ can_l(b \times h \otimes c \times g) &= (b \times h)_{\langle -1 \rangle} \otimes (b \times h)_{\langle 0 \rangle} (c \times g) \\ &= (b \times h)_1 \otimes (b \times h)_2 (c \times g) \end{aligned}$$

Let $h \in H$, then

$$\begin{aligned} &can_l(\varphi(1\#h_1) \otimes \varphi(1\#S(h_2))) \\ &= \varphi(1\#h_1)_{\langle -1 \rangle} \otimes \varphi(1\#h_1)_{\langle 0 \rangle} \varphi(1\#S(h_2)) \\ &= (1 \times h_1)_{\langle -1 \rangle} \otimes \varphi((1\#h_1)_{\langle 0 \rangle}) \varphi(1\#S(h_2)) \\ &= (1 \times h_1) \otimes \varphi(1\#h_2) \varphi(1\#S(h_2)) \\ &= (1 \times h) \otimes \varphi(1\#1) \end{aligned}$$

and similarly we can show

$$\begin{aligned} &can_l((1 \times h_1) \otimes (1 \times S(h_2))) \\ &= (1 \times h) \otimes \varphi(1\#1) \end{aligned}$$

By bijectivity of can_l , we obtain (3.4.1). \square

Now

$$\begin{aligned} \varphi((h \cdot a)\#1) &= \varphi((1\#h_1)(a\#1)(1\#S(h_2))) \\ &= \varphi(1\#h_1) \varphi(a\#1) \varphi(1\#S(h_2)) \\ &= (1 \times h_1) \varphi(a\#1) (1 \times S(h_2)) \\ &= h \cdot \varphi(a\#1) \end{aligned} \quad \text{by (3.4.1)}$$

for $a \in A$ and $h \in H$. Thus $\varphi|_A$ is H -linear.

Using the left $B \rtimes H$ -colinearity of φ and the functor Q_l , we immediately obtain the left B -colinearity of φ . Indeed

$$\varphi(a\#h)_{\langle -1 \rangle} \otimes \varphi(a\#h)_{\langle 0 \rangle} = (a\#h)_{\langle -1 \rangle} \otimes \varphi((a\#h)_{\langle 0 \rangle})$$

implies

$$q(\varphi(a\#h)_{\langle -1 \rangle}) \otimes \varphi(a\#h)_{\langle 0 \rangle} = q((a\#h)_{\langle -1 \rangle}) \otimes \varphi((a\#h)_{\langle 0 \rangle})$$

or

$$\varphi(a\#h)^{[-1]} \otimes \varphi(a\#h)^{[0]} = (a\#h)^{[-1]} \otimes \varphi((a\#h)^{[0]})$$

So far we have that A is isomorphic to B as left B -comodule algebras in the category ${}^H_H\mathcal{YD}$. By an analogue (symmetric actually) argument of the orbit statement in Proposition 2.2.5, there exists a Hopf algebra automorphism f in ${}^H_H\mathcal{YD}$ such that $\chi_B = (B \otimes f) \circ \Delta_B$. I.e. (B, Δ_B, χ_B) coincides with B^f , which again is isomorphic to $f^{-1}B$ (Remark 2.2.9). Thus

$$\varphi|_A : A \longrightarrow f^{-1}B$$

is an isomorphism of B -bicomodule algebras in ${}^H_H\mathcal{YD}$, or $A \cong i(f^{-1})$. Finally, by the commutativity of diagram (3.3.1) we get $f^{-1} \in \text{Ker}\zeta$. Indeed,

$$\begin{aligned} B \rtimes H &= A\#H \\ &= (f^{-1}B)\#H \\ &= \overline{f^{-1}}(B \rtimes H) \\ &= i'(\overline{f^{-1}}) = i'(\zeta(f^{-1})) \end{aligned}$$

By the injectivity of i' we get $f^{-1} \in \text{Ker}\zeta$. We have obtained the following theorem.

Theorem 3.4.2. *The kernel of $\xi : \text{BiGal}(B) \rightarrow \text{BiGal}(B \rtimes H)$ is given by*

$$\text{Ker}\xi = i(\text{Ker}\zeta)$$

where $\zeta : \text{CoOut}(B) \rightarrow \text{CoOut}(B \rtimes H)$ is the morphism from Theorem 3.3.2. In other words, a braided B -bi-Galois object A belongs to the kernel of ξ if A is isomorphic (as a B -bi-Galois extension) to fB , for some $f \in \text{Aut}_{\text{Hopf}}(B)$ for which $\overline{f} = f \otimes H \in \text{CoInn}(B \rtimes H)$.

3.5 Relation to lazy cohomology

As mentioned before, in [25], Cuadra and Panaite have constructed a morphism, say Γ

$$\Gamma : H_L^2(B) \longrightarrow H_L^2(B \rtimes H), \quad \sigma \longmapsto \overline{\sigma}$$

where

$$\bar{\sigma}(b \times h, b' \times h') = \sigma(b \otimes h \cdot b')\varepsilon(h')$$

for $b, b' \in B$ and $h, h' \in H$.

We have discussed that the second lazy cohomology group can be realized as a normal subgroup of the group of bi-Galois objects. We can now relate ξ and Γ .

Corollary 3.5.1. *The following diagram commutes*

$$\begin{array}{ccc} H_L^2(B) & \xrightarrow{j} & \text{BiGal}(B) \\ \downarrow \Gamma & & \downarrow \xi \\ H_L^2(B \rtimes H) & \xrightarrow{j'} & \text{BiGal}(B \rtimes H) \end{array} \quad (3.5.1)$$

Proof. By [25, Theorem 4.4 (i)] we have $B(\sigma)\#H = (B \rtimes H)(\bar{\sigma})$, which immediately gives us the commutativity of the diagram. \square

We end this section with a description of the image of the morphism $\Gamma : H_L^2(B) \rightarrow H_L^2(B \rtimes H)$.

Proposition 3.5.2. *Let $\tau : B \rtimes H \otimes B \rtimes H \rightarrow k$ be a lazy 2-cocyle on $B \rtimes H$. Then $\tau \in \text{Im}\Gamma$ if and only if τ satisfies the following identity*

$$\tau(b \times h, b' \times h') = \tau(b \times 1_H, h \cdot b' \times 1_H)\varepsilon(h') \quad (3.5.2)$$

for $b, b' \in B$ and $h, h' \in H$.

Proof. If $\sigma \in Z_L^2(B)$, then by definition, $\bar{\sigma}$ satisfies (3.5.2). Conversely, let $\tau \in Z_L^2(B \rtimes H)$ satisfy (3.5.2). Define $\sigma : B \otimes B \rightarrow k$ by

$$\sigma(b \otimes b') = \tau(b \times 1_H, b' \times 1_H)$$

Then σ is a lazy 2-cocyle on B such that $\bar{\sigma} = \tau$. Indeed, let

- Note that

$$\tau(1_B \times h, b' \times h') = \tau(1_B \times 1_H, h \cdot b' \times h') \quad \text{by (3.5.2)}$$

$$= \varepsilon_B(h \cdot b')\varepsilon_H(h') = \varepsilon_B(b')\varepsilon_H(hh') \quad (3.5.3)$$

- σ is H -linear

$$\begin{aligned}
& \sigma(h_1 \cdot b \otimes h_2 \cdot b') \\
&= \tau(h_1 \cdot b \times 1_H, h_2 \cdot b' \times 1_H) \\
&= \tau(h_1 \cdot b \times h_2, b' \times 1_H) && \text{by (3.5.2)} \\
&= \tau((1_B \times h)(b \times 1_H), b' \times 1_H) \\
&= \tau(1_B \times h_1, b_1 \times b_{2(-1)})\tau((1_B \times h_2)(b_{2(0)} \times 1_H), b' \times 1_H) && \text{by (3.5.3)} \\
&= \tau((1_B \times h)_1, (b \times 1_H)_1)\tau((1_B \times h)_2(b \times 1_H)_2, (b' \times 1_H)) \\
&= \tau((b \times 1_H)_1, (b' \times 1_H)_1)\tau((1_B \times h), (b \times 1_H)_2(b' \times 1_H)_2) \\
&= \tau(b_1 \times b_{2(-1)}, b'_1 \times b'_{2(-1)})\tau(1_B \times h, b_{2(0)}b'_{2(0)} \times 1_H) \\
&= \tau(b_1 \times b_{2(-1)}, b'_1 \times b'_{2(-1)})\varepsilon_B(b_{2(0)}b'_{2(0)})\varepsilon_H(h) && \text{by (3.5.3)} \\
&= \tau(b \times 1_H, b' \times 1_H)\varepsilon_H(h) = \varepsilon_H(h)\sigma(b \otimes b')
\end{aligned}$$

since $b_{(-1)}\varepsilon_B(b_{(0)}) = \varepsilon_B(b)1_H$.

- σ is H -colinear, i.e. we have to show

$$\begin{aligned}
b_{(-1)}b'_{(-1)}\sigma(b_{(0)} \otimes b'_{(0)}) &= b_{(-1)}b'_{(-1)}\tau(b_{(0)} \times 1_H, b'_{(0)} \times 1_H) \\
&= 1_H \sigma(b \otimes b') = 1_H \tau(b \times 1_H, b' \times 1_H)
\end{aligned}$$

Now as τ is lazy, we get

$$\begin{aligned}
& \tau(b_1 \times b_{2(-1)}, b'_1 \times b'_{2(-1)})(b_{2(0)}b'_{2(0)} \times 1_H) \\
&= \tau((b \times 1_H)_1, (b' \times 1_H)_1)(b \times 1_H)_2(b' \times 1_H)_2 \\
&= \tau((b \times 1_H)_2, (b' \times 1_H)_2)(b \times 1_H)_1(b' \times 1_H)_1 \\
&= \tau(b_{2(0)} \times 1_H, b'_{2(0)} \times 1_H)(b_1(b_{2(-2)} \cdot b'_1) \times b_{2(-1)}b'_{2(-1)})
\end{aligned}$$

Applying $\varepsilon_B \otimes H$ gives us

$$\tau(b \times 1_H, b' \times 1_H)1_H = \tau(b_{(0)} \times 1_H, b'_{(0)} \times 1_H)b_{(-1)}b'_{(-1)}$$

Hence σ is H -colinear.

- In order to have that σ is a cocycle, we have to show that

$$\begin{aligned}
& \sigma(b_1 \otimes b_{2(-1)} \cdot b'_1)\sigma(b_{2(0)}b'_2 \otimes b'') \\
&= \sigma(b'_1 \otimes b'_{2(-1)} \cdot b''_1)\sigma(b \otimes b'_{2(0)}b''_2)
\end{aligned}$$

which coincides with (2.4.1) translated to the case $\mathcal{C} = \frac{H}{H}\mathcal{YD}$. Equivalently, we want

$$\begin{aligned}
& \tau(b_1 \times 1_H, b_{2(-1)} \cdot b'_1 \times 1_H)\tau(b_{2(0)}b'_2 \times 1_H, b'' \times 1_H) \\
&= \tau(b'_1 \times 1_H, b'_{2(-1)} \cdot b''_1 \times 1_H)\tau(b \times 1_H, b'_{2(0)}b''_2 \times 1_H)
\end{aligned}$$

Now, since τ is a cocycle on $B \rtimes H$, we have

$$\begin{aligned} & \tau(b_1 \times b_{2(-1)}, b'_1 \times b'_{2(-1)})\tau(b_{2(0)}b'_{2(0)} \times 1_H, b'' \times 1_H) \\ &= \tau((b \times 1_H)_1, (b' \times 1_H)_1)\tau((b \times 1_H)_2, (b' \times 1_H)_2, b'' \times 1_H) \\ &= \tau((b' \times 1_H)_1, (b'' \times 1_H)_1)\tau((b \times 1_H), (b' \times 1_H)_2, (b'' \times 1_H)_2) \\ &= \tau(b'_1 \times b'_{2(-1)}, b''_1 \times b''_{2(-1)})\tau(b \times 1_H, b'_{2(0)}b''_{2(0)} \times 1_H) \end{aligned}$$

Applying (3.5.2) gives the desired equation.

- We have already observed that

$$\begin{aligned} & \tau(b_1 \times b_{2(-1)}, b'_1 \times b'_{2(-1)})(b_{2(0)}b'_{2(0)} \times 1_H) \\ &= \tau(b_{2(0)} \times 1_H, b'_{2(0)} \times 1_H)(b_1(b_{2(-2)} \cdot b'_1) \times b_{2(-1)}b'_{2(-1)}) \end{aligned}$$

by laziness of τ . Apply $B \otimes \varepsilon_H$ and (3.5.2) to obtain

$$\begin{aligned} & \tau(b_1 \times 1_H, b_{2(-1)} \cdot b'_1 \times 1_H)b_{2(0)}b'_2 \\ &= \tau(b_{2(0)} \times 1_H, b'_2 \times 1_H)b_1(b_{2(-1)} \cdot b'_1) \end{aligned}$$

Thus

$$\begin{aligned} & \sigma(b_1 \otimes b_{2(-1)} \cdot b'_1)b_{2(0)}b'_2 \\ &= \sigma(b_{2(0)} \otimes 1_H, b'_2)b_1(b_{2(-1)} \cdot b'_1) \end{aligned}$$

which is equivalent to the laziness condition (2.4.2) in ${}^H_H\mathcal{YD}$. Thus σ is a lazy 2-cocycle in ${}^H_H\mathcal{YD}$.

- Finally

$$\begin{aligned} \bar{\sigma}(b \times h, b' \times h') &= \sigma(b \otimes h \cdot b')\varepsilon(h') \\ &= \tau(b \times 1_H, h \cdot b' \times 1_H)\varepsilon(h') \\ &= \tau(b \times h, b' \times h') \end{aligned} \quad \text{by (3.5.2)}$$

□

3.6 An exact sequence relating all 'extending' morphisms

Let B be a braided Hopf algebra in the category of Yetter-Drinfeld modules. By Theorem 2.4.5, we have a group exact sequence

$$1 \longrightarrow \text{CoOut}^-(B) \xrightarrow{\iota_B} \text{CoOut}(B) \times H_L^2(\mathcal{C}; B) \xrightarrow{\Upsilon_B} \text{BiGal}(B)$$

But also for the k -Hopf algebra $B \rtimes H$ there's an exact sequence

$$1 \longrightarrow \text{CoOut}^-(B \rtimes H) \xrightarrow{\iota_{B \rtimes H}} \text{CoOut}(B \rtimes H) \times H_L^2(B \rtimes H) \xrightarrow{\Upsilon_{B \rtimes H}} \text{BiGal}(B \rtimes H)$$

We can relate these two sequences exactly by using the 'extending' morphisms. The only morphism missing so far is the morphism $\text{CoOut}^-(\mathcal{C}; B) \rightarrow \text{CoOut}^-(B \rtimes H)$.

Proposition 3.6.1. *There is a well-defined group morphism*

$$\begin{aligned} \zeta^- : \text{CoOut}^-(B) &\longrightarrow \text{CoOut}^-(B \rtimes H) \\ [\mu] &\longmapsto [\bar{\mu}] \end{aligned}$$

where

$$\bar{\mu}(b \times h) = \mu(b)\varepsilon(h)$$

for $b \in B$ and $h \in H$.

Proof. Take $\mu \in \text{Reg}_{aL}^1(B)$, i.e., $\mu \in \text{Reg}^1(B)$ and $\delta(\mu) \in \text{Reg}_L^2(B)$. By [25, Theorem 4.4 (v)], we already know $\bar{\mu} \in \text{Reg}^1(B)$ and $\delta(\bar{\mu}) = \overline{\delta(\mu)}$. Now $\delta(\mu) \in \text{Reg}_L^2(B)$ implies $\overline{\delta(\mu)} \in \text{Reg}_L^2(B \rtimes H)$, thus $\delta(\bar{\mu}) \in \text{Reg}_L^2(B \rtimes H)$ and $\bar{\mu} \in \text{Reg}_{aL}^1(B \rtimes H)$.

Moreover, suppose $\mu \in \text{Reg}_{aL}^1(B)$ such that $\text{ad}(\mu) \in \text{CoInn}(B)$, i.e., there exists an algebra morphism $\phi : B \rightarrow k$ in ${}^H_H\mathcal{YD}$ such that $\text{ad}(\mu) = \text{ad}(\phi)$. By Lemma 3.3.1, we have

$$\text{ad}(\bar{\mu}) = \overline{\text{ad}(\mu)} = \overline{\text{ad}(\phi)} = \text{ad}(\bar{\phi})$$

or $\bar{\mu} \in \text{ad}^{-1}(\text{CoInn}(B \rtimes H))$. Hence ζ^- is well-defined. To show that ζ^- is a group map, take $\mu, \nu \in \text{Reg}_{aL}^1(B)$. Then

$$\begin{aligned} (\bar{\mu} * \bar{\nu})(b \times h) &= \bar{\mu}(b_1 \times b_{2(-1)}h_1)\bar{\nu}(b_{2(0)} \times h_2) \\ &= \mu(b_1)\varepsilon(b_{2(-1)}h_1)\nu(b_{2(0)})\varepsilon(h_2) = \mu(b_1)\nu(b_2)\varepsilon(h) \\ &= \overline{(\mu * \nu)}(b \times h) \end{aligned}$$

□

Combining the morphisms ζ and Γ , we obtain the following result.

Corollary 3.6.2. *There is a group morphism*

$$\begin{aligned} \Omega = (\zeta \times \Gamma) : \text{CoOut}(B) \times H_L^2(B) &\longrightarrow \text{CoOut}(B \rtimes H) \times H_L^2(B \rtimes H) \\ ([\alpha], [\sigma]) &\longmapsto ([\bar{\alpha}], [\bar{\sigma}]) \end{aligned}$$

Proof. It suffices to prove

$$\begin{aligned} \overline{\alpha \circ \omega} &= \bar{\alpha} \circ \bar{\omega} \\ \overline{\sigma \leftarrow \omega * \tau} &= \bar{\sigma} \leftarrow \bar{\omega} * \bar{\tau} \end{aligned}$$

The first equation is obvious. The second one follows from the following computation.

$$\begin{aligned} (\overline{\sigma \leftarrow \omega})(b \times h, b' \times h') &= (\sigma \leftarrow \omega)(b \otimes h \cdot b')\varepsilon(h') \\ &= \sigma(\omega(b) \otimes \omega(h \cdot b'))\varepsilon(h') = \sigma(\omega(b) \otimes h \cdot \omega(b'))\varepsilon(h') \\ &= \overline{\sigma}(\omega(b) \times h, \omega(b') \times h') = (\overline{\sigma} \leftarrow \overline{\omega})(b \times h, b' \times h') \end{aligned}$$

□

Theorem 3.6.3. *Let B be a Hopf algebra in the category of left-left Yetter-Drinfeld modules ${}^H_H\mathcal{YD}$. The following diagram is commutative.*

$$\begin{array}{ccccccc} 1 & \longrightarrow & CoOut^-(B) & \xrightarrow{\iota_B} & CoOut(B) \times H_L^2(B) & \xrightarrow{\Upsilon_B} & BiGal(B) \\ & & \downarrow \zeta^- & & \downarrow \Omega & & \downarrow \xi \\ & & (I) & & (II) & & \\ 1 & \longrightarrow & CoOut^-(B \rtimes H) & \xrightarrow{\iota} & CoOut(B \rtimes H) \times H_L^2(B \rtimes H) & \xrightarrow{\Upsilon} & BiGal(B \rtimes H) \end{array} \quad (3.6.1)$$

Proof. Since $ad(\overline{\mu}) = \overline{ad(\mu)}$ and $\delta(\overline{\mu}^{-1}) = \delta(\overline{\mu^{-1}}) = \overline{\delta(\mu^{-1})}$, diagram (I) commutes. Furthermore, the commutativity of (II) follows from the commutativity of diagrams (3.3.1) and (3.5.1). □

Using diagram (3.6.1), we can give a new characterization of $Ker\Gamma$.

Let $\sigma \in Z_L^2(B)$ such that $\Gamma(\sigma) = \overline{\sigma} \in B_L^2(B \rtimes H)$. Then $j'(\overline{\sigma}) = (B \rtimes H)(\overline{\sigma}) = B \rtimes H$. On the other hand, $j'(\overline{\sigma}) = B(\sigma)\#H = \xi(B(\sigma))$ by (3.5.1). Thus $B(\sigma) \in Ker\xi$. By Theorem 3.4.2, we know there exists a morphism $f \in Aut_{Hopf}(B)$ for which $\overline{f} = f \otimes H \in CoInn(B \rtimes H)$ such that $B(\sigma) \cong {}^f B$ as bi-Galois extensions. But then $f^{-1}B(\sigma) \cong B$ by Remark 2.2.9, or $\Upsilon_B([f^{-1}], [\sigma]) = 1$. By exactness of the sequence, there exists a $\gamma \in Reg_{aL}^1(B)$ such that $(f^{-1}, \sigma) = I_B(\gamma) = (ad(\gamma), \delta(\gamma^{-1}))$. By commutativity of (I) in (3.6.1), we get $(\overline{f}^{-1}, \overline{\sigma}) = I(\overline{\gamma})$. But $\overline{f}^{-1} \in CoInn(B \rtimes H)$ and $\overline{\sigma} \in B_L^2(B \rtimes H)$, thus $I_{B \rtimes H}(\overline{\gamma}) = 1$, therefore $\overline{\gamma} \in ad^{-1}(CoInn(B \rtimes H))$. In conclusion; $\sigma = \delta(\gamma^{-1})$ and $[\gamma] \in Ker\zeta^-$. We have shown the following.

Proposition 3.6.4. *The kernel of the morphism $\Gamma : H_L^2(B) \rightarrow H_L^2(B \rtimes H)$ can be described as follows*

$$Ker\Gamma = \delta(Ker\zeta^-)$$

3.7 Example

We conclude this chapter with a computation of an example. Consider Sweedler's Hopf algebra H_4 . As an algebra, H_4 is generated by g and h with relations

$$g^2 = 1, \quad h^2 = 0, \quad gh + hg = 0$$

The comultiplication is given by

$$\begin{aligned}\Delta(g) &= g \otimes g & \Delta(h) &= 1 \otimes h + h \otimes g \\ \varepsilon(g) &= 1 & \varepsilon(h) &= 0 \\ S(g) &= g & S(h) &= gh = -hg\end{aligned}$$

It is well-known that $\text{Aut}_{\text{Hopf}}(H_4) = k^*$, where $r \in k^*$ corresponds to the automorphism f_r given by $f_r(g) = g$ and $f_r(h) = rh$. Furthermore, Bichon and Carnovale computed in [8] that $\text{CoInn}(H_4) = \text{CoInt}(H_4) \cong \text{Reg}_L^1(H_4) \cong \mathbb{Z}_2$. Thus $\text{CoOut}^-(H_4) = 1$ and $\text{CoOut}(H_4) = k^*/\mathbb{Z}_2$.

Each lazy 2-cocycle of H_4 is of the form

$$\begin{aligned}\sigma_t(1, j) &= \sigma_t(j, 1) = \varepsilon(j) \quad \text{for any } j \in H_4 \\ \sigma_t(g, g) &= 1 \\ \sigma_t(g, h) &= \sigma_t(h, g) = \sigma_t(g, gh) = \sigma_t(gh, g) = 0 \\ \sigma_t(h, h) &= \sigma_t(gh, h) = -\sigma_t(h, gh) = -\sigma_t(gh, gh) = t\end{aligned}$$

for some $t \in k$ (cf. [18]). The group $B_L^2(H_4)$ is trivial so $H_L^2(H_4) = Z_L^2(H_4) \cong k$. $\text{BiGal}(H_4) \cong k^* \rtimes k$ has been computed by Schauenburg in [69], where k^* acts on k via

$$t \leftarrow r = tr$$

for $r \in k^*$ and $t \in k$. So, the group exact sequence

$$1 \longrightarrow \text{CoOut}^-(H_4) \xrightarrow{\iota} \text{CoOut}(H_4) \rtimes H_L^2(H_4) \xrightarrow{\Upsilon} \text{BiGal}(H_4)$$

boils down to

$$\begin{aligned}1 \longrightarrow k^*/\mathbb{Z}_2 \rtimes k &\xrightarrow{\Upsilon} k^* \rtimes k \\ (r, 0) &\longmapsto (r^2, 0) \\ (1, t) &\longmapsto (1, t)\end{aligned}$$

In particular, the map Υ is injective but not necessarily surjective. The quotient of $\text{BiGal}(H_4)$ and $\text{CoOut}(H_4) \rtimes H_L^2(H_4)$ equals $k^*/(k^*)^2$. Note that the group $\text{CoOut}(H_4) \rtimes H_L^2(H_4)$ appeared as a subgroup of the Brauer group $BQ(k, H_4)$ in [62].

H_4 can be seen as the Radford biproduct of the braided Hopf algebra $B = k[X]/(X^2)$ in ${}^H_H\mathcal{YD}$, where $H = kC_2 = k\langle c \mid c^2 = 1 \rangle$ is the group Hopf algebra of the cyclic group of order 2, and kC_2 . B becomes a braided Hopf algebra via

$$\begin{aligned}\Delta(X) &= 1 \otimes X + X \otimes 1 \\ \varepsilon(X) &= 0 \\ S(X) &= -X\end{aligned}$$

and is an object in ${}^H_H\mathcal{YD}$ via

$$\begin{aligned} c \cdot X &= -X \\ \rho(X) &= c \otimes X \end{aligned}$$

The Radford biproduct $B \rtimes H$ is isomorphic to H_4 via

$$\begin{aligned} B \rtimes H &\longrightarrow H_4 \\ 1 \times c &\longmapsto g \\ X \times c &\longmapsto h \end{aligned} \tag{3.7.1}$$

It is observed in [25, Example 4.6] that any cocycle of B is of the form

$$\begin{aligned} \sigma_s(1, 1) &= 1 \\ \sigma_s(1, X) &= \sigma_s(X, 1) = 0 \\ \sigma_s(X, X) &= s \end{aligned}$$

for some $s \in k$. Moreover $H_L^2(B) \cong H_L^2(H_4) \cong k$ through the map $s \mapsto -s$. We compute the remaining groups.

Proposition 3.7.1. *Let B, H as above, then*

- $Aut_{Hopf}(B) \cong k^*$
- $CoInn(B) = CoInt(B) = 1$
- $CoOut(B) \cong k^*$
- $CoOut^-(B) = 1$

Proof. Take $r \in k^*$ and define $\alpha_r : B \rightarrow B$ by $\alpha_r(X) = rX$. It is easy to see that α_r is a bijective, H -linear and H -colinear, Hopf algebra morphism of B . Conversely, any $\alpha \in Aut_{Hopf}(B)$ has to be H -colinear, from which we can deduce that α maps X to a scalar multiple of itself.

To prove the second statement, let $\alpha \in CoInt(B)$, i.e., there exists a convolution invertible map $\phi : B \rightarrow k$ in ${}^H_H\mathcal{YD}$ such that $\alpha = ad(\phi)$. In particular, ϕ has to be H -colinear:

$$c \otimes \phi(X) = X_{(-1)} \otimes \phi(X_{(0)}) = \phi(X)_{(-1)} \otimes \phi(X)_{(0)} = 1 \otimes \phi(X)$$

implying $\phi(X) = 0$, hence $\phi = \varepsilon_B$ and $\alpha = id_B$. Thus we establish $CoInn(B) = CoInt(B) = 1$.

Consequently, we obtain $CoOut(B) = Aut_{Hopf}(B) = k^*$ and $CoOut^-(B) = 1$. \square

We can also compute ζ explicitly. Indeed, consider α_r for any $r \in k^*$ (using the notation from Proposition 3.7.1), we see that $\zeta_o(\alpha_r) = \alpha_r \otimes H$ equals the automorphism $f_r \in \text{Aut}_{\text{Hopf}}(H_4)$. Hence ζ corresponds to

$$\begin{aligned} \zeta : \text{CoOut}(B) = k^* &\longrightarrow \text{CoOut}(B \rtimes H) = k^*/\mathbb{Z}_2 \\ r &\longmapsto [r] \end{aligned}$$

Next we want to compute the group of braided B -bi-Galois objects in ${}^H_H\mathcal{YD}$. Note that for this specific braided Hopf algebra B , Femić has shown $\text{Gal}_r({}_H\mathcal{M}; B) \cong (k, +)$ [39]. The result is easily modified to obtain

Lemma 3.7.2. *Any right B -Galois object in ${}^H_H\mathcal{YD}$ is of the form $C(t) = k\langle u \mid u^2 = t \rangle$ for some $t \in k$. $C(t)$ is a left-left Yetter-Drinfeld module via*

$$\begin{aligned} c \cdot u &= -u \\ \rho(u) &= c \otimes u \end{aligned}$$

The right B -comodule structure $\chi^+ : C(t) \rightarrow C(t) \otimes B$ is defined by

$$\begin{aligned} \chi^+(1) &= 1 \otimes 1 \\ \chi^+(u) &= 1 \otimes X + u \otimes 1 \end{aligned}$$

We obtain $\text{Gal}_r({}_H^H\mathcal{YD}; B) \cong (k, +)$ as groups.

Combining Proposition 3.7.1 and Lemma 3.7.2 with Proposition 2.3.5 we attain

Corollary 3.7.3. *Let B, H as above, then $\text{BiGal}(B) \cong k^* \rtimes k$, where now k^* acts on k via*

$$t \leftarrow r = tr^2$$

for $r \in k^*$ and $t \in k$. $C(t)$ has the structure of a left B -comodule via

$$\begin{aligned} \chi^-(1) &= 1 \otimes 1 \\ \chi^-(u) &= 1 \otimes u + X \otimes 1 \end{aligned}$$

Explicitly, the isomorphism is given by

$$\Sigma : k^* \rtimes k \rightarrow \text{BiGal}(B), \quad \Sigma(r, t) = [{}^{\alpha_r}C(t)]$$

Accordingly, the group exact sequence

$$1 \longrightarrow \text{CoOut}^-(B) \xrightarrow{\iota_B} \text{CoOut}(B) \rtimes H_L^2(B) \xrightarrow{\Upsilon_B} \text{BiGal}(B)$$

reduces to Υ_B being an isomorphism.

Finally, by Theorem 3.4.2 we see $\text{Ker}\xi \cong \text{Ker}\zeta = \mathbb{Z}_2$. Alternatively, we can compute

ξ explicitly. Any braided B -bi-Galois object is of the form ${}^{\alpha_r}C(t)$ for some $r \in k^*$ and $t \in k$. By the commutativity of (II) in diagram (3.6.1), we get

$$\xi(r, t) = \xi \circ \Upsilon_B(r, t) = \Upsilon_{B \rtimes H} \circ \zeta(r, t) = \Upsilon_{B \rtimes H}(r, -t) = (r^2, -t)$$

This can also be computed directly using the classification of H_4 -bi-Galois objects from [69]. We indeed see $\text{Ker}\xi \cong \mathbb{Z}_2$. Moreover, in this way, it is easy to see $\text{Im}\xi = (k^*)^2 \rtimes k$.

We can summarize all the computations in the following diagram.

$$\begin{array}{ccccccc}
 & & 1 & & 1 & & \\
 & & \downarrow & & \downarrow & & \\
 & & \mathbb{Z}_2 & \xrightarrow{\sim} & \mathbb{Z}_2 & & \\
 & & \downarrow & & \downarrow & & \\
 1 & \longrightarrow & k^* \rtimes k & \xrightarrow{\sim} & k^* \rtimes k & \longrightarrow & 1 \\
 & & \downarrow \zeta & & \downarrow \xi & & \\
 1 & \longrightarrow & k^*/\mathbb{Z}_2 \rtimes k & \longrightarrow & k^* \rtimes k & \longrightarrow & k^*/(k^*)^2 \longrightarrow 1 \\
 & & \downarrow & & \downarrow & & \\
 & & 1 & & k^*/(k^*)^2 & & \\
 & & & & \downarrow & & \\
 & & & & 1 & &
 \end{array}$$

Chapter 4

The Brauer group of a finite quantum group

Throughout this chapter, k is assumed to be a field. A *tensor category (over k)* is a k -linear abelian rigid monoidal category. A *finite tensor category* is a tensor category if the morphism spaces are finite-dimensional k -vector spaces, all objects have finite length, every simple object has a projective cover, there are finitely many simple objects (up to isomorphism) and the unit object is simple. In this chapter, all functors are assumed to be k -linear and categories are finite.

In this chapter we will further investigate the Brauer group of a finite quantum group, which has been studied before in [91, 92]. In particular, if (H, \mathcal{R}) is a coquasitriangular Hopf algebra over k , Zhang has shown the existence of a sequence of groups

$$1 \longrightarrow Br(k) \longrightarrow BC(k, H, \mathcal{R}) \xrightarrow{\tilde{\pi}} Gal^{qc}({}_R H^*)$$

where $Gal^{qc}({}_R H^*)$ is the group of quantum commutative bi-Galois objects over ${}_R H^*$. Or dually, if (H, R) is a quasitriangular Hopf algebra, then there exists an exact sequence of groups

$$1 \longrightarrow Br(k) \longrightarrow BM(k, H, R) \xrightarrow{\tilde{\pi}} Gal^{qc}({}_R H)$$

In this chapter we will give alternative descriptions for the groups $BM(k, H, R)$ and $Gal^{qc}({}_R H)$ occurring in this sequence. This will be done in Sections 4.1 and 4.2 respectively. In Section 4.3 we will provide a new characterization for the map $\tilde{\pi} : BM(k, H, R) \rightarrow Gal^{qc}({}_R H)$. Finally, in Section 4.4, we will present an alternative approach to obtain a (quantum commutative) braided ${}_R H$ -bi-Galois object from a (braided) monoidal autoequivalence $\alpha : {}^H_H \mathcal{YD} \rightarrow {}^H_H \mathcal{YD}$ trivializable on ${}^R_H \mathcal{M}$, using results from Chapter 3.

4.1 The Brauer group versus the Brauer-Picard group

We have already recalled the definition of module categories in Definition 2.5.3. Remark that a $(\mathcal{C}, \mathcal{D})$ -bimodule category is the same as a left $\mathcal{C} \boxtimes \mathcal{D}^{op}$ -module category, where \boxtimes denotes the Deligne tensor product of abelian categories (cf. [27]). Recall from [37] the following definition of an exact module category.

Definition 4.1.1. Let \mathcal{C} be a tensor category. A \mathcal{C} -module category \mathcal{M} is said to be *exact* if for any projective object $X \in \mathcal{C}$ and every object $M \in \mathcal{M}$ the object $X * M$ is projective in \mathcal{M} .

Definition 4.1.2 ([38]). An exact \mathcal{C} -bimodule category \mathcal{M} is said to be *invertible* if there exists an exact \mathcal{C} -bimodule category \mathcal{N} such that

$$\mathcal{M} \boxtimes_{\mathcal{C}} \mathcal{N} \simeq \mathcal{N} \boxtimes_{\mathcal{C}} \mathcal{M} \simeq \mathcal{C}$$

where \mathcal{C} is viewed as a \mathcal{C} -bimodule category via the regular left and right actions of \mathcal{C} .

The group of equivalence classes of invertible \mathcal{C} -bimodule categories is called the *Brauer-Picard group of \mathcal{C}* and is denoted by $BrPic(\mathcal{C})$.

Suppose \mathcal{C} is also braided. We can turn any left \mathcal{C} -module category into a \mathcal{C} -bimodule category, the right \mathcal{C} -action is defined as follows: $M * X = X * M$ for all $X \in \mathcal{C}$ and $M \in \mathcal{M}$. A \mathcal{C} -bimodule category is said to be *one-sided* if it is equivalent to a bicomodule category with right \mathcal{C} -action induced from the left, as just described. Therefore, when \mathcal{C} is braided, the group $BrPic(\mathcal{C})$ contains a subgroup $Pic(\mathcal{C})$ consisting of equivalence classes of one-sided invertible \mathcal{C} -bimodule categories. $Pic(\mathcal{C})$ is called the *Picard group of \mathcal{C}* .

If A is an algebra in \mathcal{C} , the category of right A -modules in \mathcal{C} is naturally a left \mathcal{C} -module category via

$$\mathcal{C} \times \mathcal{C}_A \rightarrow \mathcal{C}_A, (X, M) \mapsto X \otimes M$$

Here the object $X \otimes M$ has the structure of a right A -module in \mathcal{C} via $X \otimes \mu^+$, where $\mu^+ : M \otimes A \rightarrow M$ denotes the right A -action on M .

We quote

Proposition 4.1.3 ([26, Proposition 3.4]). *Let \mathcal{C} be a braided tensor category and let A and B be exact algebras in \mathcal{C} . Then*

$$\mathcal{C}_A \boxtimes_{\mathcal{C}} \mathcal{C}_B \simeq \mathcal{C}_{A \otimes B} \tag{4.1.1}$$

As \mathcal{C}_A considered as a right \mathcal{C} -module category is equivalent to $\mathcal{C}_{\overline{A}}$, we obtain

$${}_A \mathcal{C} \boxtimes_{\mathcal{C}} {}_B \mathcal{C} \simeq \mathcal{C}_{\overline{A}} \boxtimes_{\mathcal{C}} \mathcal{C}_{\overline{B}} \simeq \mathcal{C}_{\overline{A \otimes B}} \cong \mathcal{C}_{\overline{B \otimes A}} \simeq {}_{B \otimes A} \mathcal{C} \tag{4.1.2}$$

Let (H, R) be a finite dimensional quasitriangular Hopf algebra and let \mathcal{C} be the braided monoidal category ${}_H\mathcal{M}$. We can relate the Picard group of ${}_H\mathcal{M}$ to the Brauer group of ${}_H\mathcal{M}$. Recall from Example 1.1.5(3) that ${}_H\mathcal{M}$ is a braided monoidal category with braiding

$$\begin{aligned}\psi(m \otimes n) &= R^2 \cdot n \otimes R^1 \cdot m \\ \psi^{-1}(n \otimes m) &= S(R^1) \cdot m \otimes R^2 \cdot n\end{aligned}$$

for $m \in M, n \in N$.

It is claimed in [26] that the Picard group of \mathcal{C} is isomorphic to the group of Morita equivalence classes of exact Azumaya algebras (where an algebra A is said to be *exact* if the category \mathcal{C}_A is exact). We show that, for $\mathcal{C} = {}_H\mathcal{M}$, any Azumaya algebra is exact. Accordingly, the Picard group of \mathcal{C} will be isomorphic to the Brauer group of ${}_H\mathcal{M}$. Let us give a complete proof in the following proposition.

Proposition 4.1.4. *The Picard group of \mathcal{C} is isomorphic to the Brauer group of ${}_H\mathcal{M}$.*

$$\text{Pic}({}_H\mathcal{M}) \cong \text{BM}(k, H, R)$$

Proof. Assume A is H -Azumaya. In particular, A is an algebra in \mathcal{C} . Moreover

$$\mathcal{C}_A \simeq \overline{A}\mathcal{C} = \overline{A}({}_H\mathcal{M}) = \overline{A}\#_H\mathcal{M}$$

where \overline{A} is the opposite algebra. $\overline{A}\#_H H$ is a right H -comodule algebra with right coaction $\rho(a\#h) = (a\#h_1) \otimes h_2$ for $a \in \overline{A}, h \in H$. If we can show that $\overline{A}\#_H H$ is H -simple, then $\overline{A}\#_H H$ is exact by [3, Proposition 1.20(i)]. To prove that $\overline{A}\#_H H$ is H -simple, it is sufficient to show that \overline{A} is H -simple. Indeed, let J be an H -ideal of $\overline{A}\#_H H$. One can check that J is an H -Hopf module. By the Fundamental Theorem of Hopf modules, we obtain $J \cong I \otimes H$ as H -Hopf modules, where $I = J^{coH}$. I will then be an H -ideal of \overline{A} . If \overline{A} is shown to be H -simple, I must be trivial, implying that either $J \cong H$ or $J \cong \overline{A}\#_H H$. In the first case however, J will not be an H -ideal of $\overline{A}\#_H H$. Thus $\overline{A}\#_H H$ will not contain a non-trivial H -ideal if \overline{A} is H -simple. So let us show that \overline{A} is H -simple. Let J be a non-trivial H -ideal of \overline{A} , in particular J is an H -submodule ideal of \overline{A} . Consider $A \otimes \overline{A}$ which has the braided product

$$(a \otimes \overline{b})(c \otimes \overline{d}) = a(R^2 \cdot c) \otimes \overline{(r^2 \cdot d)(r^1 R^1 \cdot b)} \quad (4.1.3)$$

for $a, b, c, d \in A$. Consider the subset $A \otimes J$ which is now easily seen to be a non-trivial ideal of $A \otimes \overline{A}$. The latter is an Azumaya algebra (A is, hence so are \overline{A} and $A \otimes \overline{A}$). Since k is a field, $A \otimes \overline{A}$ is simple. Contradiction. Thus \overline{A} is H -simple. Hence, so is $\overline{A}\#_H H$, and therefore $\overline{A}\#_H H$ is exact. Whence $\overline{A}\#_H \mathcal{M} = \mathcal{C}_A$ is an exact module category.

By Proposition 4.1.3 and Theorem 1.3.9, we have

$$\mathcal{C}_{\overline{A}} \boxtimes_{\mathcal{C}} \mathcal{C}_A \simeq \mathcal{C}_{\overline{A} \otimes A} \simeq \mathcal{C}$$

Similarly by using (4.1.2), we get

$$\mathcal{C}_A \boxtimes_{\mathcal{C}} \mathcal{C}_{\bar{A}} \simeq \bar{A}\mathcal{C} \boxtimes_{\mathcal{C}} A\mathcal{C} \simeq_{A \otimes \bar{A}} \mathcal{C} \simeq \mathcal{C}$$

Hence, \mathcal{C}_A is an exact invertible (one-sided) module category over \mathcal{C} .

Conversely, let \mathcal{M} be an exact invertible (one-sided) module category. By [38, Proposition 4.2] we have

$$\mathcal{M} \boxtimes_{\mathcal{C}} \mathcal{M}^{op} \simeq \mathcal{M}^{op} \boxtimes_{\mathcal{C}} \mathcal{M} \simeq \mathcal{C}$$

By [3, Theorem 1.14] there exists an (exact) algebra A in ${}_H\mathcal{M}$ such that \mathcal{M} is equivalent to \mathcal{C}_A . Then $\mathcal{M}^{op} \simeq \mathcal{C}_{\bar{A}}$. Again, by using (4.1.1) and (4.1.2), we see

$$\begin{aligned} \mathcal{C} &\simeq \mathcal{M}^{op} \boxtimes_{\mathcal{C}} \mathcal{M} \simeq \mathcal{C}_{\bar{A}} \boxtimes_{\mathcal{C}} \mathcal{C}_A \simeq \mathcal{C}_{\bar{A} \otimes A} \\ \mathcal{C} &\simeq \mathcal{M} \boxtimes_{\mathcal{C}} \mathcal{M}^{op} \simeq \mathcal{C}_A \boxtimes_{\mathcal{C}} \mathcal{C}_{\bar{A}} \simeq \bar{A}\mathcal{C} \boxtimes_{\mathcal{C}} A\mathcal{C} \simeq_{A \otimes \bar{A}} \mathcal{C} \end{aligned}$$

Thus by Theorem 1.3.9 the algebra A is Azumaya.

Finally, the correspondence is one of groups because of Proposition 4.1.3. \square

4.2 Galois objects versus autoequivalences

(H, R) still denotes a finite dimensional quasitriangular Hopf algebra and \mathcal{C} denotes the tensor category ${}_H\mathcal{M}$. Let $M \in \mathcal{C}$, there are 2 ways to define a left-left Yetter-Drinfeld module structure on M , by using the R -matrix or its inverse:

$$\begin{aligned} \lambda_1(m) &= R^2 \otimes R^1 \cdot m \\ \lambda_2(m) &= SR^1 \otimes R^2 \cdot m \end{aligned}$$

This induces 2 monoidal subcategories of ${}^H_H\mathcal{YD}$, say ${}^R_H\mathcal{M}$ resp. ${}^{R^{-1}}_H\mathcal{M}$. As braided monoidal categories we get

$$\begin{aligned} ({}^R_H\mathcal{M}, \psi) &\leftrightarrow ({}^H_H\mathcal{YD}, \phi) \\ ({}^{R^{-1}}_H\mathcal{M}, \psi) &\leftrightarrow ({}^H_H\mathcal{YD}, \phi^{-1}) \end{aligned}$$

We will denote

$$\psi_{M,N} = \begin{array}{c} M \quad N \\ \frown \\ N \quad M \end{array}, \quad \psi_{M,N}^{-1} = \begin{array}{c} N \quad M \\ \smile \\ M \quad N \end{array} \quad \text{and} \quad \phi_{X,Y} = \begin{array}{c} X \quad Y \\ \smile \\ Y \quad X \end{array}, \quad \phi_{X,Y}^{-1} = \begin{array}{c} Y \quad X \\ \frown \\ X \quad Y \end{array} \quad (4.2.1)$$

for the braiding (and its inverse) of ${}_H\mathcal{M}$ and ${}^H_H\mathcal{YD}$ respectively.

It is well-known that H can be deformed into a braided Hopf algebra ${}_R H$ via Majid's transmutation process [53]. In particular, ${}_R H$ equals H as an algebra. It becomes an H -module algebra with action given by

$$h \triangleright x = h_1 x S(h_2)$$

for $h, x \in H$. One can turn ${}_R H$ into a braided Hopf algebra in ${}_H \mathcal{M}$ as follows: the counit is the same as ε_H , the comultiplication and antipode are given by

$$\begin{aligned} \underline{\Delta}(x) &= x_1 S(R^2) \otimes R^1 \triangleright x_2 \\ &= x_1 S(r^2) S(R^2) \otimes R^1 x_2 S(r^1) \\ &= x_1 r^2 S(R^2) \otimes R^1 x_2 r^1 \\ &= r^2 x_2 S(R^2) \otimes R^1 r^1 x_1 \\ &= R^2 \triangleright x_2 \otimes R^1 x_1 \end{aligned}$$

and

$$\underline{S}(x) = R^2 S(R^1 \triangleright x)$$

for $x \in H$.

As ${}_R H = H$ as algebra and since

$$(h_1 \triangleright x) \cdot (h_2 \cdot m) = h \cdot (x \cdot m)$$

for $h, x \in H$ and $m \in M$, where $M \in {}_H \mathcal{M}$, every H -module is naturally an ${}_R H$ -module. Let \mathcal{O} be the class of ${}_R H$ -modules obtained in this canonical way. Then $(\underline{\Delta}, \mathcal{O})$ is an opposite comultiplication in the sense of [52]. Furthermore, $({}_R H, \underline{\Delta}, \underline{R} = 1 \otimes 1)$ is a quasitriangular in the category ${}_H \mathcal{M}$ (see [53, Definition 1.3] or [51, Section 4]). As observed in [92], ${}_R H$ is flat in ${}_H \mathcal{M}$. Finally, the braided Hopf algebra ${}_R H$ is cocommutative cocentral, in the sense of [74], the half-braiding is defined by

$$\sigma_{{}_R H, M} : {}_R H \otimes M \rightarrow M \otimes {}_R H, \quad \sigma_{{}_R H, M}(x \otimes m) = r^2 R^1 \cdot m \otimes r^1 x R^2$$

for $m \in M$, $M \in {}_H \mathcal{M}$ and $x \in H$. Following [74], we say a bicomodule M in ${}^{R^H}({}_H \mathcal{M})^{R^H}$ *cocommutative* if

$$\chi^+ = \sigma_{{}_R H, M} \circ \chi^- = (M \xrightarrow{\chi^-} {}_R H \otimes M \xrightarrow{\sigma_{{}_R H, M}} M \otimes {}_R H)$$

Lemma 4.2.1. *Any left-left Yetter-Drinfeld module M has the structure of a cocommutative ${}_R H$ -bicomodule in the category ${}_H \mathcal{M}$. Conversely, any cocommutative ${}_R H$ -bicomodule is a left-left Yetter-Drinfeld module.*

We obtain an equivalence of braided monoidal categories ${}^H_H \mathcal{YD} \rightarrow {}^{R^H}({}_H \mathcal{M})$.

Proof. Given $(M, \cdot, \lambda) \in {}^H_H \mathcal{YD}$, then $M \in {}^{R^H}({}_H \mathcal{M})^{R^H}$ via

$$\begin{aligned} \chi^-(m) &\stackrel{not.}{=} m^{[-1]} \otimes m^{[0]} = m_{(-1)} S(R^2) \otimes R^1 \cdot m_{(0)} \\ \chi^+(m) &\stackrel{not.}{=} m^{[0]} \otimes m^{[1]} = R^2 \cdot m_{(0)} \otimes R^1 m_{(-1)} \end{aligned}$$

for $m \in M$. It is easy to see

$$\begin{aligned}\sigma_{R^H, M} \circ \chi^-(m) &= \sigma_{R^H, M}(m_{(-1)}S(P^2) \otimes P^1 \cdot m_{(0)}) \\ &= r^2 R^1 P^1 \cdot m_{(0)} \otimes r^1 m_{(-1)}S(P^2)R^2 \\ &= r^2 \cdot m_{(0)} \otimes r^1 m_{(-1)} = \chi^+(m)\end{aligned}$$

Conversely, given a cocommutative R^H -bicomodule $(N, \cdot, \chi^-, \chi^+)$, then N becomes a left-left Yetter-Drinfeld module via

$$\lambda(n) = n^{[-1]}R^2 \otimes R^1 \cdot n^{[0]}$$

or

$$\lambda(n) = SR^1 n^{[1]} \otimes R^2 \cdot n^{[0]}$$

for $n \in N$, using the cocommutativity. For a complete proof we refer to [92, Section 3.1].

Finally, we can transfer the braiding of ${}^H_H\mathcal{YD}$ to ${}^{R^H}({}_H\mathcal{M})$ such that the equivalence becomes one of braided monoidal categories. That is, if $M, N \in {}^{R^H}({}_H\mathcal{M})$. The braiding, again denoted by ϕ , is then defined by

$$\phi_{M, N}(m \otimes n) = m^{[-1]}R^2 \cdot n \otimes R^1 \cdot m^{[0]}$$

for $m \in M$ and $n \in N$. □

As a consequence of Lemma 4.2.1, any (braided) monoidal autoequivalence $\alpha : {}^H_H\mathcal{YD} \rightarrow {}^H_H\mathcal{YD}$ can be seen as a (braided) monoidal equivalence $\alpha : {}^{R^H}({}_H\mathcal{M}) \rightarrow {}^{R^H}({}_H\mathcal{M})$ and conversely.

As in [92], we will call a braided bi-Galois object A *quantum commutative* if A is a cocommutative bi-Galois object which is commutative as an algebra in the category of left-left Yetter Drinfeld modules, that is

$$ab = (a_{(-1)} \cdot b)a_{(0)} \tag{4.2.2}$$

for all $a, b \in A$. We will denote the group of quantum commutative R^H -bi-Galois objects by $Gal^{qc}({}_R H)$. Clearly, $Gal^{qc}({}_R H)$ is a subgroup of $BiGal({}_R H)$.

The following is due to Zhu.

Proposition 4.2.2 ([92, Corollary 3.3.6]). *Let (H, R) be a finite dimensional quasi-triangular Hopf algebra. Then the group $Gal^{qc}({}_R H)$ is a subgroup of the group $Aut^{br}({}^H_H\mathcal{YD}, {}^R_H\mathcal{M})$.*

The group embedding defined in Proposition 4.2.2 is as follows; if A is quantum commutative ${}_R H$ -bi-Galois object, then $\alpha_A = A \square_{RH} -$ is a braided autoequivalence of ${}^H_H \mathcal{YD}$ (use the equivalence in Lemma 4.2.1), trivialisable on ${}^R_H \mathcal{M}$. As we have seen in Lemma 2.5.6, the functor α_A is satisfying (A). Let's denote by $Aut_{(A)}^{br}({}^H_H \mathcal{YD}, {}^R_H \mathcal{M})$ the braided autoequivalences of ${}^H_H \mathcal{YD}$ trivialisable on ${}^R_H \mathcal{M}$ and satisfying (A), then $Gal^{qc}({}_R H)$ is a subgroup of $Aut_{(A)}^{br}({}^H_H \mathcal{YD}, {}^R_H \mathcal{M})$.

Conversely let $\alpha \in Aut_{(A)}^{br}({}^H_H \mathcal{YD}, {}^R_H \mathcal{M})$. In particular, $\alpha \in Aut_{(A)}({}^H_H \mathcal{YD}, {}^R_H \mathcal{M})$. By Theorem 2.5.11, $\alpha({}_R H)$ is a faithfully flat ${}_R H$ -bi-Galois object and $\alpha \cong \alpha({}_R H) \square_{RH} -$. But then by [92, Lemma 3.2.7], $\alpha({}_R H) \square_{RH} -$ being a braided autoequivalence implies that $\alpha({}_R H)$ is quantum commutative. Thus we obtain the following proposition.

Proposition 4.2.3. *Let (H, R) be a finite dimensional quasitriangular Hopf algebra. The group of quantum commutative ${}_R H$ -bi-Galois objects is isomorphic to the group of isomorphism classes of braided autoequivalences of ${}^H_H \mathcal{YD}$ trivialisable on ${}^R_H \mathcal{M}$ and satisfying (A), that is*

$$Gal^{qc}({}_R H) \cong Aut_{(A)}^{br}({}^H_H \mathcal{YD}, {}^R_H \mathcal{M})$$

4.3 The Brauer group of a finite quantum group

We state the following lemma for future use.

Lemma 4.3.1. *Let H be a finite dimensional Hopf algebra. The categories ${}^H_H \mathcal{YD}$ and $\mathcal{YD}_{H^*}^{H^*}$ are naturally isomorphic as braided monoidal categories.*

Proof. Let $(e_i, e^i) \in H \times H^*$ be a dual basis. Any $M \in {}^H_H \mathcal{YD}$ belongs to $\mathcal{YD}_{H^*}^{H^*}$ via

$$\begin{aligned} \rho(m) &\stackrel{not.}{=} m_{\{0\}} \otimes m_{\{1\}} = e_i \cdot m \otimes e^i \\ m \leftarrow h^* &= \langle h^*, m_{(-1)} \rangle m_{(0)} \end{aligned}$$

for $m \in M$ and $p \in H^*$. Conversely, any $N \in \mathcal{YD}_{H^*}^{H^*}$, with H^* -coaction denoted by $n \mapsto n_{\{0\}} \otimes n_{\{1\}}$, is a left left Yetter-Drinfeld module over H via

$$\begin{aligned} \lambda(n) &= e_i \otimes n \leftarrow e^i \\ h \cdot n &= n_{\{0\}} \langle n_{\{1\}}, h \rangle \end{aligned}$$

for $n \in N$ and $h \in H$. The categories ${}^H_H \mathcal{YD}$ and $\mathcal{YD}_{H^*}^{H^*}$ are braided via

$$\begin{aligned} \phi(m \otimes n) &= m_{(-1)} \cdot n \otimes m_{(0)} \\ \phi'(m \otimes n) &= n_{\{0\}} \otimes m \leftarrow n_{\{1\}} \end{aligned}$$

With the identification as above, it is clear that $\phi(m \otimes n) = \phi'(m \otimes n)$. \square

Let (H, R) be a quasitriangular Hopf algebra as before. A quasitriangular Hopf algebra satisfies the *quantum Yang-Baxter equation*, that is

$$R_{12}R_{13}R_{23} = R_{23}R_{13}R_{12}$$

where $R_{12} = R^1 \otimes R^2 \otimes 1_H \in H \otimes H \otimes H$, etc. Or

$$R^1 P^1 \otimes R^2 Q^1 \otimes P^2 Q^2 = P^1 R^1 \otimes Q^1 R^2 \otimes Q^2 P^2 \quad (\text{QYBE})$$

Lemma 4.3.2. *We have*

$$u^1 p^1 U^1 \otimes u^2 r^1 R^1 \otimes p^2 r^2 \otimes U^2 R^2 = p^1 U^1 u^1 \otimes r^1 R^1 u^2 \otimes r^2 p^2 \otimes R^2 U^2 \quad (4.3.1)$$

Proof. By (QYBE) we have $R_{12}R_{13} = R_{23}R_{13}R_{12}(R^{-1})_{23}$ or

$$u^1 p^1 \otimes u^2 \otimes p^2 = p^1 u^1 \otimes q^1 u^2 S(v^1) \otimes q^2 p^2 v^2$$

Then

$$\begin{aligned} & u^1 p^1 U^1 \otimes u^2 r^1 R^1 \otimes p^2 r^2 \otimes U^2 R^2 \\ &= p^1 u^1 U^1 \otimes q^1 u^2 S(v^1) r^1 R^1 \otimes q^2 p^2 v^2 r^2 \otimes U^2 R^2 \\ &= p^1 u^1 U^1 \otimes q^1 u^2 R^1 \otimes q^2 p^2 \otimes U^2 R^2 \\ &= p^1 U^1 u^1 \otimes q^1 R^1 u^2 \otimes q^2 p^2 \otimes R^2 U^2 \end{aligned}$$

□

Dual to the construction in [91], there exists an exact sequence of groups

$$1 \longrightarrow Br(k) \longrightarrow BM(k, H, R) \xrightarrow{\tilde{\pi}} Gal^{qc}({}_R H)$$

Here $Br(k)$ is the (classical) Brauer group of the field k , $BM(k, H, R) = Br({}_H \mathcal{M})$ is the Brauer group of the braided monoidal category ${}_H \mathcal{M}$ (see Example 1.3.10(3)) and $Gal^{qc}({}_R H)$ is the group of (isomorphism classes) of quantum commutative ${}_R H$ -bi-Galois objects as in the previous section.

Let us recollect how the morphism $\tilde{\pi}$ is defined. First recall from Example 1.1.5(3) that ${}_H \mathcal{M} = \mathcal{M}^{H^*}$ as braided monoidal categories. Suppose A is an Azumaya algebra in the braided monoidal category ${}_H \mathcal{M} = \mathcal{M}^{H^*}$, that is $[A] \in BM(k, H, R) = BC(k, H^*, \mathcal{R})$. In [92, Proposition] (which is based on [91, Corollary 4.2]) it is shown that any element of $BC(k, H^*, \mathcal{R})$ can be represented by an Azumaya algebra that is a smash product. Any smash product is a Galois extension of its coinvariants (e.g. see Lemma 5.3.1), thus any element of $BC(k, H^*, \mathcal{R})$ can be represented by an Azumaya algebra that is an H^* -Galois extension of its coinvariants. As a result we're allowed to assume that our Azumaya algebra $A \in {}_H \mathcal{M} = \mathcal{M}^{H^*}$ is H^* -Galois over its coinvariant subalgebra $A_0 = A^{coH^*}$. Observe that

$$A_0 = A^{coH^*} = {}_H A = \{a \in A \mid h \cdot a = \epsilon(h)a, \forall h \in H\} \quad (4.3.2)$$

Now $\pi(A)$ is defined as the centralizer subalgebra $C_A(A_0)$ of A_0 in A . Then $\pi(A) \in \mathcal{YD}_{H^*}^{H^*}$ where $\pi(A)$ is an H^* -subcomodule of A and the right H^* -action is the Miyashita-Ulbrich-action (or MU-action), given by

$$c \leftarrow h^* = x_i(h^*)cy_i(h^*)$$

for $c \in \pi(A)$ and $h^* \in H^*$, where $x_i(h^*) \otimes y_i(h^*) = can^{-1}(1 \otimes h^*)$. By the identification in Lemma 4.3.1, we get that $\pi(A) \in {}_H^H\mathcal{YD}$ is an H -submodule of A and the left H -coaction is dual to the MU-action. As a left left Yetter-Drinfeld module, $\pi(A)$ can be seen as an ${}_R H$ -bicomodule. It is shown that $\pi(A)$ is a bi-Galois object and the morphism $\tilde{\pi} : BM(k, H, R) \rightarrow Gal^{qc}({}_R H)$ sends a class $[A]$ to $[\pi(A)]$. In the next part we will give an equivalent characterization for $\pi(A)$.

A is still assumed to be an Azumaya algebra in ${}_H\mathcal{M}$ which is H^* -Galois over A_0 . Let Z be a left-left Yetter-Drinfeld module. We can define an A^e -module structure on $A \otimes Z$ as follows

$$\mu_{A \otimes Z} = \begin{array}{c} A \otimes \bar{A} \quad A \otimes Z \\ \begin{array}{c} \text{Diagram: A box with two inputs from the left labeled } A \otimes \bar{A} \text{ and } A \otimes Z. The box contains a vertical line with a loop on the right side. The output is a vertical line labeled } A \otimes Z. \end{array} \\ A \quad Z \end{array} \quad (4.3.3)$$

with notation as in (4.2.1), or

$$(a \otimes \bar{b}) \bullet (c \otimes z) = a(R^2 \cdot c)(r^2 S^{-1}(z_{(-1)})R^1 \cdot b) \otimes r^1 \cdot z_{(0)}$$

for $a, b, c \in A$ and $z \in Z$. Indeed

$$\begin{aligned} [(a \otimes \bar{b})(c \otimes \bar{d})] \bullet (e \otimes z) &= [a(R^2 \cdot c) \otimes \overline{(r^2 \cdot d)(r^1 R^1 \cdot b)}] \cdot (e \otimes z) && \text{by (4.1.3)} \\ &= a(R^2 \cdot c)(P^2 \cdot e)(Q^2 S^{-1}(z_{(-1)})P^1 \cdot [(r^2 \cdot d)(r^1 R^1 \cdot b)] \otimes Q^1 \cdot z_{(0)}) \\ &= a(R^2 \cdot c)(P^2 p^2 \cdot e)(Q^2 S^{-1}(z_{(-1)})P^1 r^2 \cdot d)(q^2 S^{-1}(z_{(-2)})p^1 r^1 R^1 \cdot b) \otimes q^1 Q^1 \cdot z_{(0)} \\ &= a(R^2 \cdot c)(p^2 P^2 \cdot e)(Q^2 S^{-1}(z_{(-1)})r^2 P^1 \cdot d)(q^2 S^{-1}(z_{(-2)})r^1 p^1 R^1 \cdot b) \otimes q^1 Q^1 \cdot z_{(0)} \\ & && \text{by (QYBE)} \\ &= a(R^2 \cdot c)(p^2 P^2 \cdot e)(Q^2 r^2 S^{-1}(z_{(-2)})P^1 \cdot d)(q^2 r^1 S^{-1}(z_{(-1)})p^1 R^1 \cdot b) \otimes q^1 Q^1 \cdot z_{(0)} \\ & && \text{by (QT4)} \end{aligned}$$

but also

$$\begin{aligned} (a \otimes \bar{b}) \bullet [(c \otimes \bar{d}) \bullet (e \otimes z)] \\ &= (a \otimes \bar{b}) \bullet [c(P^2 \cdot e)(U^2 S^{-1}(z_{(-1)})P^1 \cdot d) \otimes U^1 \cdot z_{(0)}] \\ &= a(R^2 \cdot [c(P^2 \cdot e)(U^2 S^{-1}(z_{(-1)})P^1 \cdot d)])(q^2 S^{-1}((U^1 \cdot z_{(0)})_{(-1)})R^1 \cdot b) \end{aligned}$$

$$\begin{aligned}
& \otimes q^1 \cdot ((U^1 \cdot z_{(0)})_{(0)}) \\
= & a(R^2 \cdot c)(p^2 P^2 \cdot e)(u^2 U^2 S^{-1}(z_{(-1)})P^1 \cdot d)(q^2 S^{-1}((U^1 \cdot z_{(0)})_{(-1)})u^1 p^1 R^1 \cdot b) \\
& \otimes q^1 \cdot ((U^1 \cdot z_{(0)})_{(0)}) \\
= & a(R^2 \cdot c)(p^2 P^2 \cdot e)(u^2 U^2 Q^2 r^2 S^{-1}(z_{(-1)})P^1 \cdot d)(q^2 S^{-1}(U^1 z_{(-1)} S(r^1))u^1 p^1 R^1 \cdot b) \\
& \otimes q^1 Q^1 \cdot z_{(0)} \\
= & a(R^2 \cdot c)(p^2 P^2 \cdot e)(Q^2 r^2 S^{-1}(z_{(-2)})P^1 \cdot d)(q^2 r^1 S^{-1}(z_{(-1)})p^1 R^1 \cdot b) \otimes q^1 Q^1 \cdot z_{(0)}
\end{aligned}$$

for $a, b, c, d, e \in A$ and $z \in Z$.

Lemma 4.3.3. *Let A be an Azumaya algebra in ${}_H\mathcal{M}$ and let Z be a left-left Yetter-Drinfeld module. $A \otimes Z$ is a left-left Yetter-Drinfeld module with structures given by*

$$\begin{aligned}
h \cdot (a \otimes z) &= h_1 \cdot a \otimes h_2 \cdot z \\
\lambda_{A \otimes Z}(a \otimes z) &= SR^1 z_{-1} \otimes R^2 \cdot a \otimes z_0
\end{aligned} \tag{4.3.4}$$

for $a \in A$ and $z \in Z$.

Together with the A^e -module structure, $A \otimes Z$ becomes an object in ${}_{A^e}({}_H^H\mathcal{YD})$.

Proof. We embed A in ${}_H^H\mathcal{YD}$ by viewing it as $A \in ({}^{R^{-1}}_H\mathcal{M}, \psi)$, that is A is equipped with the H -coaction $\lambda_2(a) = SR^1 \otimes R^2 \cdot a$. We use λ_2 rather than λ_1 . Using λ_1 we would not necessarily yield that $A \otimes Z$ becomes an object in ${}_{A^e}({}_H^H\mathcal{YD})$. That being said, there is a reason to choose λ_2 over λ_1 anyhow. The reason will become clear in the proof of Proposition 4.3.5.

The given Yetter-Drinfeld module structure in the lemma now is nothing but the natural Yetter-Drinfeld module structure of the tensor product of the two left-left Yetter-Drinfeld modules A and Z .

A^e is an H -module algebra with multiplication as in (4.1.3). Note that if we consider A to be in $({}^{R^{-1}}_H\mathcal{M}, \psi)$, we have to view A^e in $({}^{R^{-1}}_H\mathcal{M}, \psi)$ as well. Thus its H -comodule structure is given by $\lambda_{A^e}(a \otimes \bar{b}) = SR^1 Sr^1 \otimes (R^2 \cdot a \otimes r^2 \cdot \bar{b})$. Let us verify that A^e then is an algebra in ${}_H^H\mathcal{YD}$.

$$\begin{aligned}
\lambda_{A^e}((a \otimes \bar{b})(c \otimes \bar{d})) &= \lambda_{A^e}(a(R^2 \cdot c) \otimes \overline{(r^2 \cdot d)(r^1 R^1 \cdot b)}) \\
&= S(P^1)S(p^1) \otimes P^2 \cdot (a(R^2 \cdot c)) \otimes \overline{p^2 \cdot ((r^2 \cdot d)(r^1 R^1 \cdot b))} \\
&= S(P^1)S(U^1)S(p^1)S(u^1) \otimes (P^2 \cdot a)(U^2 R^2 \cdot c) \otimes \overline{(p^2 r^2 \cdot d)(u^2 r^1 R^1 \cdot b)} \\
&= S(P^1)S(u^1)S(U^1)S(p^1) \otimes (P^2 \cdot a)(R^2 U^2 \cdot c) \otimes \overline{(q^2 p^2 \cdot d)(q^1 R^1 u^2 \cdot b)} \quad \text{by (4.3.1)} \\
&= S(P^1)S(u^1)S(U^1)S(p^1) \otimes (P^2 \cdot a \otimes \overline{u^2 \cdot b})(U^2 \cdot c \otimes \overline{p^2 \cdot d}) \\
&= \lambda_{A^e}(a \otimes \bar{b})\lambda_{A^e}(c \otimes \bar{d})
\end{aligned}$$

To observe that $A \otimes Z$ is an object in ${}_{A^e}(\frac{H}{H}\mathcal{YD})$, observe that

$$\begin{aligned}
& h \cdot [(a \otimes \bar{b}) \bullet (c \otimes z)] \\
&= (h_1 \cdot a \otimes \overline{h_2 \cdot b}) \bullet (h_3 \cdot c \otimes h_4 \cdot z) \\
&= (h_1 \cdot a)(R^2 h_3 \cdot c)(r^2 S^{-1}((h_4 \cdot z)_{(-1)})R^1 h_2 \cdot b) \otimes r^1 \cdot (h_4 \cdot z)_{(0)} \\
&= (h_1 \cdot a)(R^2 h_3 \cdot c)(r^2 S^{-1}(h_4 z_{(-1)})S(h_6))R^1 h_2 \cdot b) \otimes r^1 h_5 \cdot z_{(0)} \\
&= (h_1 \cdot a)(h_2 R^2 \cdot c)(r^2 h_6 S^{-1}(z_{(-1)})S^{-1}(h_4)h_3 R^1 \cdot b) \otimes r^1 h_5 \cdot z_{(0)} && \text{by (QT4)} \\
&= (h_1 \cdot a)(h_2 R^2 \cdot c)(r^2 h_4 S^{-1}(z_{(-1)})R^1 \cdot b) \otimes r^1 h_3 \cdot z_{(0)} \\
&= (h_1 \cdot a)(h_2 R^2 \cdot c)(h_3 r^2 S^{-1}(z_{(-1)})R^1 \cdot b) \otimes h_4 r^1 \cdot z_{(0)} && \text{by (QT4)} \\
&= h \cdot [a(R^2 \cdot c)(r^2 S^{-1}(z_{(-1)})R^1 \cdot b) \otimes r^1 \cdot z_{(0)}] \\
&= h \cdot [(a \otimes \bar{b}) \bullet (c \otimes z)]
\end{aligned}$$

which means that the module structure in (4.3.3) is H -linear. To show that it's H -colinear as well, we compute

$$\begin{aligned}
& \lambda_{A \otimes Z}((a \otimes \bar{b}) \bullet (c \otimes z)) \\
&= \lambda_{A \otimes Z}(a(R^2 \cdot c)(r^2 S^{-1}(z_{(-1)})R^1 \cdot b) \otimes r^1 \cdot z_{(0)}) \\
&= S(P^1)(r^1 \cdot z_{(0)})_{(-1)} \otimes P^2 \cdot [a(R^2 \cdot c)(r^2 S^{-1}(z_{(-1)})R^1 \cdot b)] \otimes (r^1 \cdot z_{(0)})_{(0)} \\
&= S(P^1)S(U^1)S(V^1)r^1 z_{(-1)}S(q^1) \otimes (P^2 \cdot a)(U^2 R^2 \cdot c)(V^2 r^2 p^2 q^2 S^{-1}(z_{(-2)})R^1 \cdot b) \\
&\quad \otimes p^1 \cdot z_{(0)} && \text{by (QT4)} \\
&= S(P^1)S(U^1)S(q^1)z_{(-2)} \otimes (P^2 \cdot a)(U^2 R^2 \cdot c)(p^2 S^{-1}(z_{(-1)})q^2 R^1 \cdot b) \otimes p^1 \cdot z_{(0)} \\
&\quad \text{by (QT4)} \\
&= S(P^1)S(q^1)S(U^1)z_{(-2)} \otimes (P^2 \cdot a)(R^2 U^2 \cdot c)(p^2 S^{-1}(z_{(-1)})R^2 q^1 \cdot b) \otimes p^1 \cdot z_{(0)} \\
&\quad \text{by (QYBE)} \\
&= S(P^1)S(q^1)S(U^1)z_{(-1)} \otimes (P^2 \cdot a \otimes q^1 \cdot b) \bullet (U^2 \cdot c \otimes p^1 \cdot z_{(0)}) \\
&= (a \otimes \bar{b})_{(-1)}(c \otimes z)_{(-1)} \otimes (a \otimes \bar{b})_{(0)} \bullet (c \otimes z)_{(0)}
\end{aligned}$$

□

Let A be an H^* -Galois Azumaya algebra in ${}_H\mathcal{M}$ and let Z be a left-left Yetter-Drinfeld module. The previous lemma allows us to consider $(A \otimes Z)^A$, where $(-)^A$ is from the equivalence pair

$$A \overset{\sim}{\otimes} - : \frac{H}{H}\mathcal{YD} \rightleftarrows {}_{A^e}(\frac{H}{H}\mathcal{YD}) : (-)^A$$

(similarly) as in [15, Proposition 2.6]. Then

$$(A \otimes Z)^A = \left\{ \sum c_i \otimes z_i \mid \sum (a \otimes 1) \bullet (c_i \otimes z_i) = \sum (1 \otimes \bar{a}) \bullet (c_i \otimes z_i), \forall a \in A \right\}.$$

which is a Yetter-Drinfeld submodule of $A \otimes Z$ with the same Yetter-Drinfeld module structures as in (4.3.4).

By Lemma 4.2.1, we can view Z as a left ${}_R H$ -comodule in ${}_H \mathcal{M}$, thus we can consider $\pi(A) \square_{{}_R H} Z$. We will relate $(A \otimes Z)^A$ and $\pi(A) \square_{{}_R H} Z$, but first we need an equivalent characterization for the cotensor product of two ${}_R H$ -bicomodules in ${}_H \mathcal{M}$ (which is dual to [91, Lemma 2.9]).

Lemma 4.3.4. *If X and Y are two YD modules, then*

$$X \square_{{}_R H} Y = \left\{ \sum x_i \otimes y_i \in X \otimes Y \mid x_{i(-1)} R^2 \otimes x_{i(0)} \otimes R^1 \cdot y_i = S(R^1) y_{i(-1)} \otimes R^2 \cdot x_i \otimes y_{i(0)} \right\}$$

Proof. Given $\sum x_i \otimes y_i \in X \square_{{}_R H} Y$, using the identification in Lemma 4.2.1, we get

$$\begin{aligned} & \sum x_{i(-1)} R^2 \otimes x_{i(0)} \otimes R^1 \cdot y_i \\ &= \sum S(r^1) x_i^{[1]} R^2 \otimes r^2 \cdot x_i^{[0]} \otimes R^1 \cdot y_i \\ &= \sum S(r^1) y_i^{[-1]} R^2 \otimes r^2 \cdot x_i \otimes R^1 \cdot y_i^{[0]} \\ &= \sum S(r^1) y_{i(-1)} S(P^2) R^2 \otimes r^2 \cdot x_i \otimes R^1 P^1 \cdot y_{i(0)} \\ &= \sum S(r^1) y_{i(-1)} \otimes r^2 \cdot x_i \otimes y_{i(0)} \end{aligned}$$

Conversely, suppose $\sum x_i \otimes y_i$ belongs to the set on the right hand side, then

$$\begin{aligned} & \sum \chi^+(x_i) \otimes y_i = \sum R^2 \cdot x_{i(0)} \otimes R^1 x_{i(-1)} \otimes y_i \\ &= \sum R^2 \cdot x_{i(0)} \otimes R^1 x_{i(-1)} u^2 S(v^2) \otimes v^1 u^1 \cdot y_i \\ &= \sum R^2 u^2 \cdot x_i \otimes R^1 S(u^1) y_{i(-1)} S(v^2) \otimes v^1 \cdot y_{i(0)} \\ &= \sum x_i \otimes y_{i(-1)} S(v^2) \otimes v^1 \cdot y_{i(0)} = \sum x_i \otimes \chi^-(y_i) \end{aligned}$$

□

This implies that we can define a coaction on $X \square_{{}_R H} Y$

$$\lambda \left(\sum x_i \otimes y_i \right) = \sum x_{i(-1)} R^2 \otimes x_{i(0)} \otimes R^1 \cdot y_i = \sum S(R^1) y_{i(-1)} \otimes R^2 \cdot x_i \otimes y_{i(0)}$$

Together with the diagonal H-action

$$h \cdot \sum x_i \otimes y_i = \sum h_1 \cdot x_i \otimes h_2 \cdot y_i$$

this will define a left-left Yetter-Drinfeld module structure on $X \square_{RH} Y$. Indeed

$$\begin{aligned}
\lambda(h \cdot (\sum x_i \otimes y_i)) &= \sum \lambda(h_1 \cdot x_i \otimes h_2 \cdot y_i) \\
&= \sum S(R^1)(h_2 \cdot y_i)_{(-1)} \otimes R^2 h_1 \cdot x_i \otimes (h_2 \cdot y_i)_{(0)} \\
&= \sum S(R^1) h_2 y_{i(-1)} S(h_4) \otimes R^2 h_1 \cdot x_i \otimes h_3 \cdot y_{i(0)} \\
&= \sum h_1 S(R^1) y_{i(-1)} S(h_4) \otimes h_1 R^2 \cdot x_i \otimes h_3 \cdot y_{i(0)} \\
&= \sum h_1 (S(R^1) y_{i(-1)}) S(h_3) \otimes h_2 \cdot (R^2 \cdot x_i \otimes y_{i(0)})
\end{aligned}$$

The corresponding ${}_{RH}$ -bicomodule structure is the natural ${}_{RH}$ -structure of the cotensor product. E.g.

$$\begin{aligned}
\sum \chi_{X \square_{RH} Y}^-(x_i \otimes y_i) &= \sum (x_i \otimes y_i)_{(-1)} S(R^2) \otimes R^1 \cdot (x_i \otimes y_i)_{(0)} \\
&= \sum x_{i(-1)} r^2 S(R^2) \otimes R^1 \cdot (x_{i(0)} \otimes r^1 \cdot y_i) \\
&= \sum x_{i(-1)} r^2 S(P^2) S(R^2) \otimes R^1 \cdot x_{i(0)} \otimes P^1 r^1 \cdot y_i \\
&= \sum x_{i(-1)} S(R^2) \otimes R^1 \cdot x_{i(0)} \otimes y_i = \sum \chi_X^-(x_i) \otimes y_i
\end{aligned}$$

and similarly $\chi_{X \square_{RH} Y}^+ = X \otimes \chi_Y^+$. Thus we could have deduced the Yetter-Drinfeld module structure from the natural ${}_{RH}$ -bicomodule structure as well.

Particularly for $\pi(A) \square_{RH} Z$, we get

$$\lambda(\sum c_i \otimes z_i) = \sum c_{i-1} R^2 \otimes c_{i0} \otimes R^1 \cdot z_i = \sum S R^1 z_{i-1} \otimes R^2 \cdot c \otimes z_{i0} \quad (4.3.5)$$

for $\sum c_i \otimes z_i \in \pi(A) \square_{RH} Z$.

The following statement is inspired by [91, Lemma 4.5].

Proposition 4.3.5. *Let A be an H^* -Galois Azumaya algebra in ${}_{H}\mathcal{M}$ and let Z be a left-left Yetter-Drinfeld module structure. Then*

$$(A \otimes Z)^A = \pi(A) \square_{RH} Z$$

as left-left Yetter-Drinfeld modules.

Proof. Let $\sum c_i \otimes z_i \in \pi(A) \square_{RH} Z$ and denote $c \otimes z = \sum c_i \otimes z_i$, then

$$\begin{aligned}
\chi^+(c) \otimes z &= c \otimes \chi^-(z) \\
R^2 \cdot c_{(0)} \otimes R^1 c_{(-1)} \otimes z &= c \otimes z_{(-1)} S(R^2) \otimes R^1 \cdot z_{(0)}
\end{aligned} \tag{†}$$

Observe that

$$\begin{aligned}
(1 \otimes \bar{a}) \bullet (c \otimes z) &= (R^2 \cdot c)(r^2 S^{-1}(z_{(-1)})R^1 \cdot a) \otimes r^1 \cdot z_{(0)} \\
&= (R^2 r^2 \cdot c_{(0)})(S^{-1}(c_{(-1)})S^{-1}(r^1)R^1 \cdot a) \otimes z && \text{by } (\dagger) \\
&= c_{(0)}(S^{-1}(c_{(-1)}) \cdot a) \otimes z \\
&= (c_{(-1)}S^{-1}(c_{(-2)}) \cdot a)c_{(0)} \otimes z && \text{by (4.2.2)} \\
&= ac \otimes z = (a \otimes 1) \bullet (c \otimes z)
\end{aligned}$$

whence $\pi(A)\square_{RH}Z \subset (A \otimes Z)^A$. Conversely let $c \otimes z = \sum c_i \otimes z_i \in (A \otimes Z)^A$. Then

$$ac \otimes z = (R^2 \cdot c)(r^2 S^{-1}(z_{(-1)})R^1 \cdot a) \otimes r^1 \cdot z_{(0)} \quad \text{by } (\dagger)$$

for all $a \in A$. But then by (4.3.2), we obtain $ac \otimes z = ca \otimes z$ for all $a \in A_0$. Thus $c \otimes z \in \pi(A) \otimes Z$. As A is assumed to be H^* -Galois, we know that $\pi(A) \in \mathcal{YD}_{H^*}^{H^*}$ where $c \leftarrow h^* = x_i(h^*)cy_i(h^*)$. With the identification $\mathcal{YD}_{H^*}^{H^*} = {}_H^H\mathcal{YD}$ from Lemma 4.3.1 in mind, note that

$$x_i(h^*)y_i(h^*)_{(0)} \otimes y_i(h^*)_{(1)} = 1_A \otimes h^* \quad \text{by (1.4.5)}$$

or equivalently

$$x_i(h^*)_{(0)}y_i(h^*) \otimes x_i(h^*)_{(1)} = 1_A \otimes S(h^*)$$

hence

$$x_i(h^*)_{(0)}y_i(h^*) \langle x_i(h^*)_{(1)}, h \rangle = 1_A \langle S(h^*), h \rangle$$

or

$$(h \cdot x_i(h^*))y_i(h^*) = 1_A \langle h^*, S(h) \rangle \quad (4.3.6)$$

for $h \in H$ and $h^* \in H^*$. We can now show that $c \otimes z \in \pi(A)\square_{RH}Z$, that is $c \otimes z$ satisfies (\dagger) . Let $h^* \in H^*$ and compute

$$\begin{aligned}
&R^2 \cdot c_{(0)} \otimes z \langle h^*, R^1 c_{(-1)} \rangle \\
&= R^2 \cdot c_{(0)} \otimes z \langle h_1^*, R^1 \rangle \langle h_2^*, c_{(-1)} \rangle \\
&= R^2 \cdot (c \leftarrow h_2^*) \otimes z \langle h_1^*, R^1 \rangle \\
&= R^2 \cdot (x_i(h_2^*)cy_i(h_2^*)) \otimes z \langle h_1^*, R^1 \rangle \\
&= R^2 \cdot ((P^2 \cdot c)(p^2 S^{-1}(z_{(-1)})P^1 \cdot x_i(h_2^*))y_i(h_2^*)) \otimes p^1 \cdot z \langle h_1^*, R^1 \rangle && \text{by } (\dagger) \\
&= (R^2 P^2 \cdot c) \otimes p^1 \cdot z \langle h_1^*, R^1 \rangle \langle h_2^*, S(p^2 S^{-1}(z_{(-1)})P^1) \rangle && \text{by (4.3.6)} \\
&= (R^2 P^2 \cdot c) \otimes p^1 \cdot z \langle h^*, R^1 S(P^1)_{z_{(-1)}} S(p^2) \rangle \\
&= c \otimes p^1 \cdot z \langle h^*, z_{(-1)} S(p^2) \rangle
\end{aligned}$$

Hence $c \otimes z \in \pi(A) \square_{RH} Z$.

As $\pi(A)$ is an H -submodule of A and both objects have the diagonal H -action, the equality is H -linear. The H -colinearity is clear from the definition of the H -coactions in (4.3.4) and (4.3.5). Moreover, this illustrates why in the definition of $\lambda_{A \otimes Z}$ we have opted for λ_2 instead of λ_1 . \square

${}_RH$ is naturally a left ${}_RH$ -comodule in ${}_H\mathcal{M}$ via $\underline{\Delta}$, or equivalently, by Lemma 4.3.1, ${}_RH$ is a left-left Yetter-Drinfeld module via \triangleright and Δ , i.e. $x_{(-1)} \otimes x_{(0)} = x_1 \otimes x_2$.

By the previous proposition, we obtain

$$\pi(A) \cong \pi(A) \square_{RH} RH \cong (A \otimes {}_RH)^A$$

as left-left Yetter-Drinfeld modules. Since both A and ${}_RH$ are algebras in ${}_H\mathcal{M}$, so is $A \otimes {}_RH$, with multiplication given by

$$(a \otimes x)(b \otimes y) = a(R^2 \cdot b) \otimes (R^1 \triangleright x)y$$

for $a, b \in A$ and $x, y \in {}_RH$. As a matter of fact, with H -module and H -comodule structure as in (4.3.4), $A \otimes {}_RH$ is actually an algebra in ${}^H_H\mathcal{YD}$. Indeed

$$\begin{aligned} \lambda_{A \otimes {}_RH}((a \otimes x)(b \otimes y)) &= \lambda_{A \otimes {}_RH}(a(R^2 \cdot b) \otimes (R^1 \triangleright x)y) \\ &= S(P^1)((R^1 \triangleright x)y)_{(-1)} \otimes P^2 \cdot (a(R^2 \cdot b)) \otimes ((R^1 \triangleright x)y)_{(0)} \\ &= S(P^1)S(p^1)(R^1 \triangleright x)_{(-1)}y_{(-1)} \otimes (P^2 \cdot a)(p^2 R^2 \cdot b) \otimes (R^1 \triangleright x)_{(0)}y_{(0)} \\ &= S(P^1)S(p^1)R^1 x_1 S(V^1)y_1 \otimes (P^2 \cdot a)(p^2 R^2 U^2 V^2 \cdot b) \otimes (U^1 \triangleright x_2)y_2 \\ &= S(P^1)x_1 S(V^1)y_1 \otimes (P^2 \cdot a)(U^2 V^2 \cdot b) \otimes (U^1 \triangleright x_2)y_2 \\ &= (S(P^1)x_1)(S(V^1)y_1) \otimes (P^2 \cdot a \otimes x_2)(V^2 \cdot b \otimes y_2) \\ &= \lambda_{A \otimes {}_RH}(a \otimes x)\lambda_{A \otimes {}_RH}(b \otimes y) \end{aligned}$$

Lemma 4.3.6. *Let A be an Azumaya algebra in ${}_H\mathcal{M}$. Then $(A \otimes {}_RH)^A$ is a subalgebra of $A \otimes Z$ in ${}^H_H\mathcal{YD}$.*

Proof. By (4.3.3) and the definition of $(A \otimes {}_RH)^A$, $\sum c_i \otimes x_i$ belongs to $(A \otimes {}_RH)^A$ if and only if

$$\sum ac_i \otimes x_i = \sum (R^2 \cdot c_i)(r^2 S^{-1}(x_{i1})R^1 \cdot a) \otimes r^1 \cdot x_{i2} \quad (4.3.7)$$

Assume $\sum c_i \otimes x_i$ and $\sum d_j \otimes y_j$ belong to $(A \otimes_R H)^A$, then

$$\begin{aligned}
& \sum (1 \otimes \bar{a}) \bullet ((c_i \otimes x_i)(d_j \otimes y_j)) \\
&= \sum (1 \otimes \bar{a}) \bullet (c_i(R^2 \cdot d_k) \otimes (R^1 \triangleright x_i)y_j) \\
&= \sum [P^2 \cdot (c_i(R^2 \cdot d_j))][p^2 S^{-1}((R^1 \triangleright x_i)_1 y_{j_1}) P^1 \cdot a] \otimes p^1 \cdot [(R^1 \triangleright x_i)_2 y_{j_2}] \\
&= \sum (P^2 \cdot c_i)(Q^2 R^2 U^2 V^2 \cdot d_j)(p^2 q^2 S^{-1}(R^1 x_{i_1} S(V^1) y_{j_1}) Q^1 P^1 \cdot a) \\
&\quad \otimes (p^1 U^1 \triangleright x_{i_2})(q^1 \triangleright y_{j_2}) \\
&= \sum (P^2 \cdot c_i)(U^2 V^2 \cdot d_j)(p^2 q^2 S^{-1}(y_{j_1}) V^1 S^{-1}(x_{i_1}) P^1 \cdot a) \\
&\quad \otimes (p^1 U^1 \triangleright x_{i_2})(q^1 \triangleright y_{j_2}) \\
&= \sum (P^2 \cdot c_i)(U^2 \cdot [(V^2 \cdot d_j)(q^2 S^{-1}(y_{j_1}) V^1 S^{-1}(x_{i_1}) P^1 \cdot a)]) \\
&\quad \otimes (U^1 \triangleright x_{i_2})(q^1 \triangleright y_{j_2}) \\
&= \sum (P^2 \cdot c_i)(U^2 \cdot [(S^{-1}(x_{i_1}) P^1 \cdot a) d_j]) \otimes (U^1 \triangleright x_{i_2}) y_j \quad \text{by (4.3.7)} \\
&= \sum (P^2 \cdot c_i)(U^2 S^{-1}(x_{i_1}) P^1 \cdot a)(p^2 \cdot d_j) \otimes (p^1 U^1 \triangleright x_{i_2}) y_j \\
&= \sum a c_i(p^2 \cdot d_j) \otimes (p^1 \triangleright x_i) y_j \quad \text{by (4.3.7)} \\
&= \sum (a \otimes 1) \bullet ((c_i \otimes x_i)(d_j \otimes y_j))
\end{aligned}$$

So $\sum (c_i \otimes x_i)(d_j \otimes y_j)$ belongs to $(A \otimes_R H)^A$, which finishes the proof. \square

Theorem 4.3.7. *Let A be an Azumaya algebra in ${}_H\mathcal{M}$ which is H^* -Galois over A_0 , then*

$$\pi(A) \cong (A \otimes_R H)^A$$

as left-left Yetter-Drinfeld module algebras, or equivalently, as ${}_R H$ -bicomodule algebras. Thus they represent the same object in the group of quantum commutative Galois objects $\text{Gal}^{qc}({}_R H)$.

Proof. So far we have established that $\pi(A) \cong \pi(A) \square_{{}_R H} {}_R H \cong (A \otimes_R H)^A$ as left-left Yetter-Drinfeld modules. $(A \otimes_R H)^A$ is an algebra with multiplication

$$\sum (c_i \otimes x_i)(d_j \otimes y_j) = \sum c_i(R^2 \cdot d_j) \otimes (R^1 \cdot x_i) y_j \quad (4.3.8)$$

for $\sum c_i \otimes x_i, \sum d_j \otimes y_j \in (A \otimes_R H)^A$, or equivalently $\sum c_i \otimes x_i, \sum d_j \otimes y_j \in \pi(A) \square_{{}_R H} {}_R H$. $\pi(A) \square_{{}_R H} {}_R H$ is the cotensor product of $\pi(A)$ and ${}_R H$ in the category ${}_H\mathcal{M}$, in particular, it has an algebra structure induced by the algebra structure of $\pi(A) \otimes {}_R H$ in ${}_H\mathcal{M}$, which equals the algebra structure in (4.3.8). \square

It's a future research goal to investigate whether we can use this new characterization to prove surjectivity of $\tilde{\pi}$.

Define

$$F_A : {}^H\mathcal{YD} \rightarrow {}^H\mathcal{YD} : Z \mapsto (A \otimes Z)^A$$

Then

$$F_A(Z) = \pi(A)\square_{RH}Z$$

as left-left Yetter-Drinfeld modules, for any $Z \in {}^H\mathcal{YD}$. But as $\pi(A)$ is a quantum commutative braided bi-Galois object over RH , $\pi(A)\square_{RH}-$ is a braided monoidal equivalence, thus so is F_A . In addition, by Lemma 2.5.5, we know that $\pi(A)\square_{RH}- : {}^{RH}({}^H\mathcal{M}) \rightarrow {}^{RH}({}^H\mathcal{M})$ is trivializable on ${}^R\mathcal{M}$, which in this particular case is easy to see; if $X \in {}^R\mathcal{M} \subset {}^H\mathcal{YD}$, then its induced left RH -coaction (as in Lemma 4.2.1) is trivial, indeed

$$\chi^-(x) = x_{(-1)}S(R^2) \otimes R^1 \cdot x_{(0)} = r^2S(R^2) \otimes R^1r^1 \cdot x = 1 \otimes x$$

for $x \in X$, whence $\pi(A)\square_{RH}X \cong X$.

It’s also interesting to investigate the trivializability of F_A itself. If $X \in {}^R\mathcal{M}$, (4.3.3) becomes

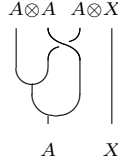

or $A \otimes X = A \tilde{\otimes} X$, where $(A \tilde{\otimes} -, (-)^A)$ is the equivalence pair of A being Azumaya. Thus $(A \otimes X)^A = (A \tilde{\otimes} X)^A \cong X$. In other words, the A^e -module structure of $A \otimes Z$ in (4.3.3) is equal to the A^e -module structure of $A \tilde{\otimes} Z$, with the following 'twist' inserted into it,



which is trivial whenever $Z \in {}^R\mathcal{M}$.

Composing the morphism $\tilde{\pi} : Br({}^H\mathcal{M}) \rightarrow Gal^{qc}({}^RH)$ with the group isomorphism $Gal^{qc}({}^RH) \cong Aut_{(A)}^{br}({}^H\mathcal{YD}, {}^R\mathcal{M})$ from Proposition 4.2.3, we obtain a group morphism

$$Br({}^H\mathcal{M}) \rightarrow Aut_{(A)}^{br}({}^H\mathcal{YD}, {}^R\mathcal{M})$$

which maps a class $[A]$ to the class of natural isomorphisms represented by F_A (notation as above). By construction, the following diagram commutes.

$$\begin{array}{ccccccc}
 1 & \longrightarrow & Br(k) & \longrightarrow & Br({}_H\mathcal{M}) & \xrightarrow{\tilde{\pi}} & Gal^{qc}({}_R H) \\
 & & & & & \searrow & \downarrow \sim \\
 & & & & & & Aut_{(A)}^{br}({}_H^H\mathcal{YD}, {}_H^R\mathcal{M})
 \end{array}$$

In view of Proposition 4.1.4, we can also say we obtain a group morphism

$$Pic({}_H\mathcal{M}) \rightarrow Aut_{(A)}^{br}({}_H^H\mathcal{YD}, {}_H^R\mathcal{M})$$

The kernel of this morphism is, by construction, isomorphic to the Brauer group of k . The latter is, again by Proposition 4.1.4 (replace H by the Hopf algebra k), isomorphic to the Picard group $Pic({}_k\mathcal{M})$ consisting of equivalence classes of one-sided invertible ${}_k\mathcal{M}$ -bimodule categories. Let us summarize in the following theorem.

Theorem 4.3.8. *Assume (H, R) is a finite dimensional quasitriangular Hopf algebra. The following diagram commutes:*

$$\begin{array}{ccccccc}
 1 & \longrightarrow & Br(k) & \longrightarrow & BM(k, H, R) & \xrightarrow{\tilde{\pi}} & Gal^{qc}({}_R H) \\
 & & \sim \downarrow & & \sim \downarrow & & \downarrow \sim \\
 1 & \longrightarrow & Pic({}_k\mathcal{M}) & \longrightarrow & Pic({}_H\mathcal{M}) & \longrightarrow & Aut_{(A)}^{br}({}_H^H\mathcal{YD}, {}_H^R\mathcal{M})
 \end{array}$$

Remark 4.3.9. Note that Davydov and Nikshych constructed a group (iso)morphism $Pic(\mathcal{C}) \rightarrow Aut^{br}(\mathcal{Z}(\mathcal{C}), \mathcal{C})$ for any braided tensor category \mathcal{C} (under stronger conditions) in [26]. In particular for $\mathcal{C} = {}_H\mathcal{M}$ they would obtain a group (iso)morphism $Pic({}_H\mathcal{M}) \rightarrow Aut^{br}({}_H^H\mathcal{YD}, {}_H^R\mathcal{M})$. The two constructions are independent and we don't know whether they are equal. If they would be, this approach by monoidal auto-equivalences would render the surjectivity of $\tilde{\pi}$, i.e. the right exactness of Zhang's sequence, at least under the same conditions as in [26]. In particular, the field k is then assumed to be algebraically closed and of characteristic 0. But then the classical Brauer group $Br(k)$ is trivial, so injectivity was already established under this assumption.

4.4 Relation with the morphism ξ

Let (H, R) , with $R = R^1 \otimes R^2$, be a quasitriangular Hopf algebra. Let F denote H^{cop} . F is quasitriangular with $\mathcal{R}(p \otimes q) = p(R^2)q(R^1)$, for $p, q \in F$. The category ${}^F\mathcal{M}$ is braided via

$$\psi'(m \otimes n) = n_{\{0\}} \otimes m_{\{0\}} \mathcal{R}(n_{\{-1\}} \otimes m_{\{-1\}})$$

for $M, N \in {}^F\mathcal{M}$, $m \in M$ and $n \in N$.

Lemma 4.4.1. *The categories ${}_H\mathcal{M}$ and ${}^F\mathcal{M}$ are isomorphic as braided monoidal categories.*

Sketch of proof. Let $(e_i, e^i) \in H \times H^*$ be a dual basis. Any $M \in {}_H\mathcal{M}$ is an F -comodule via

$$\lambda(m) \stackrel{\text{not.}}{=} m_{\{-1\}} \otimes m_{\{0\}} = e^i \otimes e_i \cdot m$$

for $m \in M$. Conversely, any $N \in {}^F\mathcal{M}$, with F -coaction denoted by $n \mapsto n_{\{-1\}} \otimes n_{\{0\}}$, is an H -module via

$$h \cdot n = \langle n_{\{-1\}}, h \rangle n_{\{0\}}$$

for $n \in N$ and $h \in H$. The categories ${}_H\mathcal{M}$ and ${}^F\mathcal{M}$ are braided via

$$\begin{aligned} \psi(m \otimes n) &= R^2 \cdot n \otimes R^1 \cdot m \\ \psi'(m \otimes n) &= n_{\{0\}} \otimes m_{\{0\}} \mathcal{R}(n_{\{-1\}} \otimes m_{\{-1\}}) \end{aligned}$$

respectively. Identifying ${}_H\mathcal{M}$ and ${}^F\mathcal{M}$, it's easy to see $\psi = \psi'$. \square

We have a similar result for the categories of Yetter-Drinfeld modules. Note that ${}^F_F\mathcal{YD}$ is braided via

$$\begin{aligned} \phi'(m \otimes n) &= m_{\{-1\}} \cdot n \otimes m_{\{0\}} \\ \phi'^{-1}(m \otimes n) &= n_{\{0\}} \otimes S^{-1}(n_{\{-1\}}) \cdot m \end{aligned}$$

for $M, N \in {}^F_F\mathcal{YD}$, $m \in M$ and $n \in N$.

Lemma 4.4.2. *The categories $({}^H_H\mathcal{YD}, \phi)$ and $({}^F_F\mathcal{YD}, \phi'^{-1})$ are braided monoidal isomorphic.*

Sketch of proof. Let $(e_i, e^i) \in H \times H^*$ be a dual basis. Let $M \in {}^H_H\mathcal{YD}$. We know from Lemma 4.4.1 that $\lambda(m) = e^i \otimes e_i \cdot m \in F \otimes M$ defines an F -coaction on M . Define

$$f \cdot m = \langle f, S^{-1}(m_{(-1)}) \rangle m_{(0)}$$

for $m \in M$ and $f \in F$. Then M becomes an object in ${}^F_F\mathcal{YD}$. Conversely, suppose $N \in {}^F_F\mathcal{YD}$. As in Lemma 4.4.1, N is an H -module via $h \cdot n = \langle n_{\{-1\}}, h \rangle n_{\{0\}}$. One can check that

$$\lambda(n) = e_i \otimes S_F^{-1}(e^i) \cdot n$$

defines an H -coaction on N , turning N into an object in ${}^H_H\mathcal{YD}$.

Finally let $M, N \in {}^H_H\mathcal{YD} = {}^F_F\mathcal{YD}$ and $m \in M$ and $n \in N$. Then

$$\begin{aligned} \phi'^{-1}(m \otimes n) &= n_{\{0\}} \otimes S^{-1}(n_{\{-1\}}) \cdot m \\ &= e_i \cdot y \otimes S_F^{-1}(e^i) \cdot x \\ &= e_i \cdot y \otimes \langle S_F^{-1}(e^i), S^{-1}(x_{(-1)}) \rangle x_{(0)} \\ &= x_{(-1)} \cdot y \otimes x_{(0)} = \phi(m \otimes n) \end{aligned}$$

as $S_F = (S_H^{-1})^*$. \square

Let M be any F -module. Using the (inverse) R -matrix \mathcal{R}^{-1} , we can define a natural F -module structure on M as follows:

$$f \blacktriangleright m = \mathcal{R}^{-1}(f \otimes m_{\{-1\}})m_{\{0\}} = \mathcal{R}(f \otimes S_F^{-1}(m_{\{-1\}}))m_{\{0\}}$$

for $m \in M$ and $f \in F$. Then M becomes a left-left F -Yetter-Drinfeld module. Let's denote the category of F -comodules with induced module structure by ${}_{\mathcal{R}^{-1}}F\mathcal{M}$. The category $({}_{\mathcal{R}^{-1}}F\mathcal{M}, \psi')$ is a braided subcategory of $({}^F_F\mathcal{YD}, \phi'^{-1})$. Under the identification $({}^H_H\mathcal{YD}, \phi) = ({}^F_F\mathcal{YD}, \phi'^{-1})$, we have $({}^R_H\mathcal{M}, \psi) = ({}_{\mathcal{R}^{-1}}F\mathcal{M}, \psi')$. Consequently, R_H becomes a braided Hopf algebra in ${}_{\mathcal{R}^{-1}}F\mathcal{M} \subset {}^F_F\mathcal{YD}$. Thus, we can consider the Radford biproduct ${}^R_H \rtimes F$.

The categories ${}^R_H({}^F\mathcal{M})$ and ${}^R_H \rtimes F\mathcal{M}$ can be naturally identified. If $(M, \lambda, \chi^-) \in {}^R_H({}^F\mathcal{M})$, with notation as before: $\lambda(m) = m_{\{-1\}} \otimes m_{\{0\}} \in F \otimes M$ and $\chi^-(m) = m^{[-1]} \otimes m^{[0]} \in {}^R_H \otimes M$, then $(M, \chi_l) \in {}^R_H \rtimes F\mathcal{M}$ where

$$\chi_l(m) \stackrel{\text{not.}}{=} m_{\langle -1 \rangle} \otimes m_{\langle 0 \rangle} = (m^{[-1]} \times m^{[0]}_{\{-1\}}) \otimes m^{[0]}_{\{0\}}$$

for $m \in M$. Conversely, if $(M, \chi_l) \in {}^R_H \rtimes F\mathcal{M}$, then $(M, \lambda, \chi^-) \in {}^R_H({}^F\mathcal{M})$ where

$$\begin{aligned} \lambda(m) &= p(m_{\langle -1 \rangle}) \otimes m_{\langle 0 \rangle} \\ \chi^-(m) &= q(m_{\langle -1 \rangle}) \otimes m_{\langle 0 \rangle} \end{aligned}$$

where $p = \varepsilon_{{}^R_H} \otimes F : {}^R_H \rtimes F \rightarrow F$ and $q = {}^R_H \otimes \varepsilon_F : {}^R_H \rtimes F \rightarrow {}^R_H$ are the natural projections (as in Chapter 3).

Combining Lemma 4.2.1, Lemma 4.4.1 and the previous categorical identification, we obtain:

$${}^H_H\mathcal{YD} \cong {}^R_H({}^H_H\mathcal{M}) \cong {}^R_H({}^F\mathcal{M}) \cong {}^R_H \rtimes F\mathcal{M}$$

Accordingly, any $\alpha \in \text{Aut}_{(A)}^{br}({}^H_H\mathcal{YD}, {}^R_H\mathcal{M})$ can in particular be seen as monoidal equivalence

$$\alpha : {}^R_H \rtimes F\mathcal{M} \rightarrow {}^R_H \rtimes F\mathcal{M}$$

By Proposition 2.5.1, there exists a bi-Galois object D over ${}^R_H \rtimes F$ such that

$$\alpha = D \square -$$

Here the unadorned cotensor product is over the Radford biproduct: $\square = \square_{{}^R_H \rtimes F}$. α can be extended to

$$\alpha = D \square - : {}^R_H \rtimes F\mathcal{M}^{{}^R_H \rtimes F} \rightarrow {}^R_H \rtimes F\mathcal{M}^{{}^R_H \rtimes F}$$

By assumption, α is trivializable on ${}^H_H\mathcal{M} = {}^F\mathcal{M}$. Hence

$$F \cong D \square F \quad \text{in } {}^R_H \rtimes F\mathcal{M}^{{}^R_H \rtimes F}$$

Lemma 4.4.3. *The morphism*

$$\sigma : D \square F \rightarrow D, \quad d \otimes f \mapsto d \langle f, 1 \rangle$$

is an ${}_R H \rtimes F$ -bilinear algebra morphism.

Proof. σ is obviously a left ${}_R H \rtimes F$ -colinear algebra map. It is also right ${}_R H \rtimes F$ -colinear, since $d \otimes f \in D \square F$ implies

$$d_{\langle 0 \rangle} \otimes d_{\langle 1 \rangle} \otimes f = d \otimes 1 \times f_1 \otimes f_2$$

or, after applying $D \otimes {}_R H \otimes F \otimes \varepsilon_F$

$$d_{\langle 0 \rangle} \otimes d_{\langle 1 \rangle} \langle f, 1 \rangle = d \otimes 1 \times f$$

and thus

$$\begin{aligned} & (\sigma \otimes {}_R H \rtimes F)(\chi_r)_{(D \square F)}(d \otimes f) \\ &= (\sigma \otimes {}_R H \rtimes F)(d \otimes f_1 \otimes 1 \times f_2) \\ &= d \langle f_1, 1 \rangle \otimes 1 \times f_2 \\ &= d \otimes 1 \times f \\ &= d_{\langle 0 \rangle} \otimes d_{\langle 1 \rangle} \langle f, 1 \rangle \\ &= (\chi_r)_D(\sigma(d \otimes f)) \end{aligned}$$

□

Consider the composition

$$F \cong D \square F \xrightarrow{\sigma} D$$

which is a ${}_R H \rtimes F$ -bilinear algebra morphism. By Theorem 3.2.9, there exists a braided ${}_R H$ -bi-Galois object D_0 in ${}^F \mathcal{YD}$, such that

$$D \cong D_0 \# F$$

as ${}_R H \rtimes F$ -bicomodule algebras.

Proposition 4.4.4. *Let $M \in {}^R H(F \mathcal{M}) = {}^R H \rtimes F \mathcal{M}$. Then*

$$D \square M \cong D_0 \square_{{}_R H} M$$

in ${}^R H(F \mathcal{M}) = {}^R H \rtimes F \mathcal{M}$.

Proof. It suffices to show $(D_0 \# F) \square M \cong D_0 \square_{{}_R H} M$. Let $(a \# f) \otimes m = \sum (a_i \# f_i) \otimes m_i \in (D_0 \# F) \square M$, i.e.

$$\begin{aligned} & (a^{[0]} \# a^{[1]}_{\{-1\}} f_1) \otimes (a^{[1]}_{\{0\}} \times f_2) \otimes m \\ &= (a \# f) \otimes m_{\langle -1 \rangle} \otimes m_{\langle 0 \rangle} \\ &= (a \# f) \otimes (m^{[-1]} \times m^{[0]}_{\{-1\}}) \otimes m^{[0]}_{\{0\}} \end{aligned}$$

Applying $D_0 \otimes \varepsilon_F \otimes {}_R H \otimes \varepsilon_F \otimes M$, we get

$$a^{[0]} \otimes a^{[1]} \langle f, 1_H \rangle \otimes m = a \langle f, 1_H \rangle \otimes m^{[-1]} \otimes m^{[0]}$$

or $a \langle f, 1_H \rangle \otimes m \in D_0 \square_{{}_R H} M$. Set $\vartheta : D \square M \rightarrow D_0 \square_{{}_R H} M$, $\vartheta((a \# f) \otimes m) = a \langle f, 1_H \rangle \otimes m$.

Applying $D_0 \otimes \varepsilon_F \otimes \varepsilon_{{}_R H} \otimes F \otimes M$ yields

$$a \otimes f \otimes m = a \langle f, 1_H \rangle \otimes m_{\{-1\}} \otimes m_{\{0\}}$$

That is, if we set $\vartheta^{-1} : D_0 \square_{{}_R H} M \rightarrow (D_0 \# F) \square M$, $\vartheta^{-1}(a \otimes m) = (a \# m_{\{-1\}}) \otimes m_{\{0\}}$, then $\vartheta^{-1} \circ \vartheta = id$. To verify that ϑ^{-1} is well-defined, observe that $a \otimes m \in D_0 \square_{{}_R H} M$ implies

$$a^{[0]} \otimes a^{[1]} \otimes m = a \otimes m^{[-1]} \otimes m^{[0]}$$

and

$$\begin{aligned} & \chi_r(a \# m_{\{-1\}}) \otimes m_{\{0\}} \\ &= (a^{[0]} \# a^{[1]}_{\{-1\}} m_{\{-1\}1}) \otimes (a^{[1]}_{\{0\}} \times m_{\{-1\}2}) \otimes m_{\{0\}} \\ &= (a \# m^{[-1]}_{\{-1\}} m^{[0]}_{\{-1\}1}) \otimes (m^{[-1]}_{\{0\}} \times m^{[0]}_{\{-1\}2}) \otimes m^{[0]}_{\{0\}} \\ &= (a \# m^{[-1]}_{\{-1\}} m^{[0]}_{\{-1\}}) \otimes (m^{[-1]}_{\{0\}} \times m^{[0]}_{\{0\}\{-1\}}) \otimes m^{[0]}_{\{0\}\{0\}} \\ &= (a \# m_{\{-1\}}) \otimes (m_{\{0\}}^{[-1]} \times m_{\{0\}\{-1\}}^{[-1]}) \otimes m_{\{0\}\{0\}}^{[-1]} \quad \text{by (3.1.7)} \\ &= (a \# m_{\{0\}}) \otimes \chi_l(m_{\{0\}}) \end{aligned}$$

whence $\vartheta^{-1}(a \otimes m) = (a \# m_{\{-1\}}) \otimes m_{\{0\}} \in (D_0 \# F) \square M$. Finally, we obviously have $\vartheta \circ \vartheta^{-1} = id$. \square

By the previous proposition, we obtain $\alpha \cong D_0 \square_{{}_R H} - : {}_R H({}^F \mathcal{M}) \rightarrow {}_R H({}^F \mathcal{M})$. Consequently, we obtain

$$\alpha({}_R H) \cong D \square_{{}_R H} \cong D_0 \square_{{}_R H} {}_R H \cong D_0 \quad (4.4.1)$$

Let us summarize. Let $\alpha : {}^H_H \mathcal{YD} \rightarrow {}^H_H \mathcal{YD}$ be a (braided) monoidal autoequivalence, trivalizable on ${}^R_H \mathcal{M}$. We can identify ${}^H_H \mathcal{YD} \cong {}_R H \rtimes {}^F \mathcal{M}$. Thus α can be seen as a monoidal equivalence $\alpha : {}_R H \rtimes {}^F \mathcal{M} \rightarrow {}_R H \rtimes {}^F \mathcal{M}$. By the classical bi-Galois theory, [68, Corollary 5.7] in particular, there exists an ${}_R H \rtimes {}^F$ -bi-Galois object D such that $\alpha \cong D \square -$. The fact that α is trivalizable, implies that D belongs to the image of the morphism $\xi : BiGal({}_R H) \rightarrow BiGal({}_R H \rtimes {}^F)$. In other words, $D_0 = D^{coF}$ is a braided ${}_R H$ -bi-Galois object. Then one can show that $\alpha \cong D \square - \cong D_0 \square_{{}_R H} -$. If α is braided, D_0 must be quantum commutative by [92, Lemma 3.2.7]. So the results from Chapter 3 provide an alternative way of obtaining a (quantum commutative) braided ${}_R H$ -bi-Galois object from a (braided) monoidal autoequivalence $\alpha : {}^H_H \mathcal{YD} \rightarrow {}^H_H \mathcal{YD}$, trivalizable on ${}^R_H \mathcal{M}$. Finally, (4.4.1) shows that this approach gives the same braided ${}_R H$ -bi-Galois object (up to isomorphism) as the approach from Section 4.2.

Chapter 5

The equivariant Brauer group of a cocommutative Hopf algebra

The goal of this chapter is to generalize Beattie's exact sequence to the case where H is a projective cocommutative Hopf algebra which is not necessarily finitely generated.

In Section 5.1, we first recollect the definition of the bigger Brauer group, following [76, 12]. Next, we will introduce the equivariant Brauer group $BRM(k, H)$ of the cocommutative Hopf algebra H consisting of equivalence classes of H -module Taylor algebras (with or without a unit). Later in the chapter we will construct a group morphism $BRM(k, H) \rightarrow Gal(k, H)$. To obtain surjectivity of this morphism, we will need to rely on the theory of multiplier Hopf algebras. For that reason we will recall the definition of multiplier Hopf algebras in Section 5.2. Multiplier Hopf algebras were originally introduced by Van Daele [80]. The main concern in Section 5.3 is the construction of H -Galois objects from (flat) H -module Taylor-Azumaya algebras. This process will induce a well-defined group morphism $\tilde{\pi} : BRM(k, H) \rightarrow Gal(k, H)$. We will prove this fact in Section 5.4 and moreover compute the kernel of $\tilde{\pi}$. Under the assumption that H has a faithful surjective integral, we will prove in Section 5.5, that $\tilde{\pi}$ becomes surjective. Finally, in Section 5.6 we will illustrate our results by considering the following examples; k is a field, H is the group Hopf algebra kG , or H is the tensor product of a group Hopf algebra and a finitely generated cocommutative Hopf algebra. All the material in this chapter originates from [31].

5.1 Equivariant Brauer group

Taylor proposed an extension of the notion of a central separable algebra [76] and introduced a Brauer group consisting of equivalence classes of Azumaya algebras without a unit, a group which can be seen as a generalization of the Brauer group of a commutative ring (Example 1.3.10(1)). An interesting rectification is given in [13], while another equivalent characterization of this new concept is provided by Caenepeel in [12]

Let k be a commutative ring and A be a k -algebra not necessarily with a unit. A is called *unital* (or *idempotent*) if the natural morphism $A \otimes_A A \rightarrow A$ is an isomorphism. In particular, the multiplication map $m : A \otimes A \rightarrow A$ is surjective. Similarly, we call an A -module M *unital* if the map $A \otimes_A M \rightarrow M$ is an isomorphism. If the algebra A has a unit, it is unital and every module is unital. For a unital algebra A , we denote the category of unital A -modules by ${}_A\mathcal{M}^u$. Similarly, we can define the notion of a unital right module or a unital bimodule.

Consider the enveloping algebra $A^e = A \otimes A^{op}$. If A is unital then A^e is also unital. By Remark 1.3.8, the category ${}_{A^e}\mathcal{M}^u$ is naturally isomorphic to ${}_A\mathcal{M}_A^u$, the category of unital A -bimodules. A is naturally a unital left and right A^e -module, we will denote A_l respectively A_r for A when viewed as a left respectively right A^e -module.

Definition 5.1.1. A *Taylor-Azumaya algebra* is a unital, faithful k -algebra which satisfies the following equivalent conditions

- (1) There exists an invertible k -module I such that the functors

$$\begin{aligned} F : {}_k\mathcal{M} &\rightarrow {}_{A^e}\mathcal{M}^u : N \mapsto A_l \otimes N \\ G : {}_{A^e}\mathcal{M}^u &\rightarrow {}_k\mathcal{M} : M \mapsto (A_r \otimes I) \otimes_{A^e} M \end{aligned}$$

form a pair of inverse equivalences

- (2) The functors

$$\begin{aligned} F : {}_k\mathcal{M} &\rightarrow {}_{A^e}\mathcal{M}^u : N \mapsto A_l \otimes N \\ G_l : {}_{A^e}\mathcal{M}^u &\rightarrow {}_k\mathcal{M} : M \mapsto \text{Hom}_{A^e}(A_l, M) \end{aligned}$$

form a pair of inverse equivalences.

The *center* of a unital k -algebra A is defined as $Z(A) = \text{End}_{A^e}(A)$. $Z(A)$ is a commutative k -algebra with unit and A is a $Z(A)$ -algebra. A Taylor-Azumaya algebra A is always k -central. Moreover, A then is finitely generated A^e -projective. If a Taylor-Azumaya algebra A contains a unit, it is a central separable algebra as in [32]. Proofs for these statements, as well as other characterizations, can be found in [12]. Unlike in the unital case, a Taylor-Azumaya algebra A is not necessary faithfully projective over k . E.g., [13] provide an example of a Taylor-Azumaya algebra which is not flat as a k -module. However, in view of the equivalence functors in definition 5.1.1, $A \otimes -$ preserves and reflects exact sequences between the categories ${}_k\mathcal{M}$ and ${}_{A^e}\mathcal{M}^u$.

Definition 5.1.2. A *dual pair* of k -modules consists of two k -modules M and M' , equipped with a surjective k -linear map $\mu : M' \otimes M \rightarrow k$. We denote $\underline{M} = (M, M', \mu)$. A morphism between two dual pairs $\underline{M} = (M, M', \mu)$ and $\underline{N} = (N, N', \nu)$ is given by a pair of k -linear maps $\underline{f} = (f, f')$, with $f : M \rightarrow N$ and $f' : M' \rightarrow N'$, such that $\mu = \nu \circ (f' \otimes f)$.

We can associate a unital k -algebra to a dual pair $\underline{M} = (M, M', \mu)$, denoted and defined by $E_k(\underline{M}) = M \otimes M'$ as k -modules and with multiplication given by

$$(m_1 \otimes m'_1)(m_2 \otimes m'_2) = \mu(m'_1 \otimes m_2)(m_1 \otimes m'_2)$$

for $m_1, m_2 \in M$ and $m'_1, m'_2 \in M'$. $E_k(\underline{M})$ is called the (*associated*) *elementary algebra*. M is a unital left $E_k(\underline{M})$ -module and M' is a unital right $E_k(\underline{M})$ -module. The actions are defined by

$$\begin{aligned} (m \otimes m') \cdot n &= \mu(m' \otimes n)m \\ n' \cdot (m \otimes m') &= \mu(n' \otimes m)m' \end{aligned}$$

Finally, every elementary algebra $E_k(\underline{M})$ is a Taylor-Azumaya algebra.

Example 5.1.3.

- If M is a finitely generated projective k -module, then $(M, M^*, \langle -, - \rangle)$ is a dual pair, where $\langle m^*, m \rangle = m^*(m)$ is the evaluation map. Moreover $E_k(\underline{M}) \cong \text{End}(M)$.
- If $E_k(\underline{M})$, where $\underline{M} = (M, M', \mu)$, has a unit, then M and M' are finitely generated projective, $M' \cong M^*$ and μ is the evaluation map. Then $E_k(\underline{M}) \cong \text{End}(M)$.

Definition 5.1.4. Let A and B be unital k -algebras. We say A and B are *Morita equivalent* (notation: $A \sim B$) if they can be connected by a strict Morita context.

For the following proposition, we refer to [12, Prop. 3.1.1].

Proposition 5.1.5. *Let A and B be Taylor-Azumaya algebras. The following are equivalent.*

- (1) A and B are Morita equivalent
- (2) $A \otimes B^{op}$ is an elementary algebra
- (3) there exist dual pairs \underline{M} and \underline{N} such that

$$A \otimes E_k(\underline{M}) \cong B \otimes E_k(\underline{N})$$

Taylor defined in [76] a bigger Brauer group by considering Morita equivalence classes of Taylor-Azumaya algebras. To ensure that these equivalence classes form a set, Taylor claimed that any central separable algebra is equivalent to a subalgebra of a finitely generated Taylor-Azumaya algebra. However [13] pointed out that the proof is only valid if the central separable algebra is flat. To overcome this logical problem, they have proposed to consider two Brauer groups $BR(k)$ and $Br'(k)$, defined by considering classes represented by a flat Taylor-Azumaya algebra, respectively by a finitely generated Taylor-Azumaya algebra.

In both cases, the multiplication is induced by the tensor product, i.e. $[A][B] = [A \otimes B]$. The identity is given by $[k]$ (or $[E_k(\underline{M})]$, where \underline{M} is a dual pair of k -modules) and the inverse of a class $[A]$ is given by $[A^{op}]$. Note that k is obviously flat and finitely generated as a k -module and A^{op} is flat (respectively finitely generated) whenever A is.

Both $BR(k)$ and $Br'(k)$ contain the classical Brauer group $Br(k)$. Furthermore $BR(k)$ is contained in $Br'(k)$, it is not known whether $BR(k) = Br'(k)$. Finally, if k is a field, then $Br(k) = BR(k) = Br'(k)$.

Let H be a k -Hopf algebra. Similar to (2.1.2), a unital k -algebra A is called an H -module algebra if A is an H -module such that the multiplication $m : A \otimes A \rightarrow A$

$$h \cdot (ab) = \sum (h_1 \cdot a)(h_2 \cdot b)$$

If H is a cocommutative Hopf algebra and if A and B are H -module algebras, then the tensor product $A \otimes B$ is again an H -module algebra. We can look at Taylor-Azumaya algebras which are simultaneously H -module algebras.

Definition 5.1.6. If A is a Taylor-Azumaya algebra and an H -module algebra at the same time, we call A an H -module Taylor-Azumaya algebra, or an H -Taylor-Azumaya algebra.

For example, we call $\underline{M} = (M, M', \mu)$ a dual pair of H -modules if M and M' are H -modules and the map μ is H -linear, i.e.

$$\begin{aligned} \mu(h \cdot (m' \otimes m)) &= \sum \mu(h_1 \cdot m' \otimes h_2 \cdot m) \\ &= \epsilon(h) \mu(m' \otimes m) \end{aligned}$$

for $m \in M$, $m' \in M'$ and $h \in H$. For such a dual pair of H -modules, the associated elementary algebra is an H -module algebra with induced H -action

$$h \cdot (m \otimes m') = \sum h_1 \cdot m \otimes h_2 \cdot m'$$

$E_k(\underline{M})$ is an H -module Taylor-Azumaya algebra, called an elementary H -module Taylor-Azumaya algebra.

For two H -Taylor-Azumaya algebras A and B to be equivalent, we demand the bimodules in the Morita context to be H -modules too and the bimodule isomorphisms

have to be H -linear. If such a strict Morita context exists, we say A and B are H -Morita equivalent or Morita equivalent as H -module algebras. Notation: $A \sim_H B$. Proposition 5.1.5 then can be generalized to

Proposition 5.1.7. *Let A and B be H -Taylor-Azumaya algebras. The following conditions are equivalent.*

- (1) A and B are Morita equivalent as H -module algebras
- (2) $A \otimes B^{op}$ is an elementary H -module algebra
- (3) there exist dual pairs of H -modules \underline{M} and \underline{N} such that

$$A \otimes E_k(\underline{M}) \cong B \otimes E_k(\underline{N})$$

as H -module algebras.

We can now define the set $BRM(k, H)$ of H -Morita equivalence classes of H -module Taylor-Azumaya algebras represented by a flat H -module Taylor-Azumaya algebra, as well as the set $BM'(k, H)$ of H -Morita equivalence classes of H -module Taylor-Azumaya algebras represented by a finitely generated H -module Taylor-Azumaya algebra. $BRM(k, H)$ and $BM'(k, H)$ are groups with multiplication induced by the tensor product: $[A][B] = [A \otimes B]$. The identity is given by $[k]$ or $[E_k(\underline{M})]$, for \underline{M} a dual pair of H -modules. The inverse of a class $[A]$ is given by $[A^{op}]$.

If no confusion can occur, we speak of the *equivariant Brauer group of H* and rely on notation to make clear which group we are working with. In this chapter though, we will deal mostly with $BRM(k, H)$.

We have two natural embeddings $BR(k) \hookrightarrow BRM(k, H) : [A] \mapsto [A]$ and $Br'(k) \hookrightarrow BM'(k, H) : [A] \mapsto [A]$, by associating to a Taylor-Azumaya algebra A the trivial H -action. If k is a field, $BM'(k, H) = BRM(k, H) = BM(k, H)$, the Brauer group of H -module Azumaya algebras.

5.2 Multiplier Hopf algebras

We first recall the definition of a multiplier algebra of a (possibly non-unitary) algebra A . A *left multiplier* is a right A -linear map $\lambda : A \rightarrow A$, a *right multiplier* is a left A -linear map $\rho : A \rightarrow A$. A *multiplier* is a pair $x = (\lambda, \rho)$, with λ a left multiplier and ρ a right multiplier, such that $\rho(a)b = a\lambda(b)$ for all $a, b \in A$. We also denote $\lambda(a) = xa$ and $\rho(a) = ax$. We denote the set of multipliers of A by $M(A)$.

The set $M(A)$ is an algebra with unit. The product is defined as follows

$$(\lambda_1, \rho_1)(\lambda_2, \rho_2) = (\lambda_1 \circ \lambda_2, \rho_2 \circ \rho_1)$$

for $(\lambda_1, \rho_1), (\lambda_2, \rho_2) \in M(A)$. If A has a unit, then $M(A) = A$.

There is a canonical algebra map $A \rightarrow M(A)$, associating to an element $a \in A$

the natural linear maps λ_a and ρ_a such that $\lambda_a(c) = ac$ and $\rho_a(c) = ca$. If the multiplication on A is non-degenerate ($ab = 0$ for all $b \in A$ implies $a = 0$ and $ab = 0$ for all $a \in A$ implies $b = 0$), this map is an embedding. One then also calls A a non-degenerate algebra. Moreover, A can be seen as a dense two-sided ideal in $M(A)$, by *dense* we mean that $xa = 0$ (or $ax = 0$) for all $a \in A$ implies $x = 0$. In fact, the multiplier algebra $M(A)$ then can be characterized as the largest unitary algebra containing A as a dense two-sided ideal. Some more elementary properties of $M(A)$ are given in [43, Prop 1.6].

In [16], the multiplier algebra of an elementary algebra is computed.

Proposition 5.2.1. *Let $\underline{M} = (M, M', \mu)$ be a dual pair and denote $E = E_k(\underline{M})$. The multiplier algebra $M(E)$ is isomorphic to*

$$\overline{E} = \{(f, f') \in E_1 \times E_2 \mid \mu(m' \otimes f(m)) = \mu(f'(m') \otimes m), \forall m \in M, m' \in M'\}$$

where $E_1 = \text{End}(M)$ and $E_2 = \text{End}(M')^{op}$.

Sketch of proof. We can define a map

$$\alpha : \overline{E} \rightarrow M(E), \quad \alpha(f, f') = (f \otimes M', M \otimes f')$$

Furthermore, as μ is surjective, there exist $q_i \in M'$ and $p_i \in M$ such that $\mu(\sum_i q_i \otimes p_i) = 1$. The inverse is given by

$$\alpha^{-1} : M(E) \rightarrow \overline{E}, \quad \alpha^{-1}(\rho_1, \rho_2) = (f, f')$$

where

$$\begin{aligned} f(m) &= \sum_i \rho_1(m \otimes q_i) p_i \\ f'(m') &= \sum_i q_i \rho_2(p_i \otimes m') \end{aligned}$$

for all $m \in M$ and $m' \in M'$. □

The definition of a multiplier Hopf algebra (over a field) is due to Van Daele [80]. Let A be a non-degenerate k -projective algebra.

Definition 5.2.2. An algebra map $\Delta : A \rightarrow M(A \otimes A)$ for which $\Delta(a)(1 \otimes b)$ and $(a \otimes 1)\Delta(b)$ belong to $A \otimes A$ for all $a, b \in A$ is called *coassociative* if

$$(a \otimes 1 \otimes 1)(\Delta \otimes \iota)(\Delta(b)(1 \otimes c)) = (\iota \otimes \Delta)((a \otimes 1)\Delta(b))(1 \otimes 1 \otimes c)$$

for all $a, b, c \in A$.

Note that if A is a non-degenerate k -projective algebra, the multiplication on $A \otimes A$ is again non-degenerate. We then have embeddings $A \otimes A \subset M(A) \otimes M(A) \subset M(A \otimes A)$, giving meaning to the above condition.

Definition 5.2.3. A *multiplier Hopf algebra* is a non-degenerate k -projective algebra A equipped with a coassociative algebra map $\Delta : A \rightarrow M(A \otimes A)$, called the *comultiplication* such that the following maps $T_1, T_2 : A \otimes A \rightarrow A \otimes A$ are bijective

$$\begin{aligned} T_1 : A \otimes A &\rightarrow A \otimes A, & T_1(a \otimes b) &= \Delta(a)(1 \otimes b) \\ T_2 : A \otimes A &\rightarrow A \otimes A, & T_2(a \otimes b) &= (a \otimes 1)\Delta(b) \end{aligned}$$

Furthermore, A is endowed with an algebra map $\epsilon : A \rightarrow k$, the *counit*, and an antihomomorphism $S : A \rightarrow M(A)$, the *antipode* satisfying

$$\begin{aligned} (\epsilon \otimes A)(\Delta(a)(1 \otimes b)) &= ab \\ (A \otimes \epsilon)((a \otimes 1)\Delta(b)) &= ab \\ m(S \otimes A)(\Delta(a)(1 \otimes b)) &= \epsilon(a)b \\ m(A \otimes S)((a \otimes 1)\Delta(b)) &= \epsilon(b)a \end{aligned}$$

for all $a, b \in A$. Finally, a multiplier Hopf algebra is called *regular* if the antipode is a bijective map $S : A \rightarrow A$.

A multiplier Hopf algebra with identity is a Hopf algebra and vice versa. It is well-known that the dual of a finitely generated projective Hopf algebra again is a Hopf algebra. This property is lifted to the infinite case -under certain circumstances- if we work with multiplier Hopf algebras, as shown in [81]. However, we must stress the fact that most of the results on multiplier Hopf algebras are obtained when working over a field. Caution is needed when working over a commutative ring k . For example, when working over a field, the unicity of a left integral (if it exists) is automatically fulfilled.

Example 5.2.4. Let G be a group, possibly infinite. Denote $A = k(G) = \bigoplus_{g \in G} kp_g$, where $p_g : kG \rightarrow k$, $p_g(h) = \delta_{g,h}$. Then $M(A) = (kG)^*$ and similarly $M(A \otimes A) = (kG \times kG)^*$ (as $A \otimes A$ can be identified with $k(G \times G)$). Define $\Delta : A \rightarrow M(A \otimes A)$ by

$$\Delta(f)(s, t) = f(st)$$

for $s, t \in G$. Then Δ is a comultiplication as in definition 5.2.2. The counit and the antipode are defined by

$$\begin{aligned} \epsilon(f) &= f(e) \\ S(f)(t) &= f(t^{-1}) \end{aligned}$$

for all $f \in A$ and $t \in G$.

In [35, 34], a Sweedler notation for multiplier Hopf algebras is suggested. We do not necessarily have that $\Delta(a)$ is in $A \otimes A$, however we do have that $\Delta(a)(1 \otimes b) \in A \otimes A$ for all $a, b \in A$. One can write $\sum_{(a)} a_1 \otimes a_2 b$ for this expression. Nevertheless, we must always keep in mind that herein the formal expression $\sum_{(a)} a_1 \otimes a_2$ is dependent

of b . We say that the factor a_2 is covered by b . In [43], another Sweedler-like notation is introduced, one which takes this dependence into account. For $a, b \in A$, denote

$$\begin{aligned}\Delta(a)(1 \otimes b) &= \sum a_{(1,b)} \otimes a_{(2,b)} \\ (b \otimes 1)\Delta(a) &= \sum a_{(b,1)} \otimes a_{(b,2)}\end{aligned}$$

The coassociativity is then translated to

$$\begin{aligned}(a \otimes 1 \otimes 1)(\Delta \otimes \iota)(\Delta(b)(1 \otimes c)) &= (\iota \otimes \Delta)((a \otimes 1)\Delta(b))(1 \otimes 1 \otimes c) \\ \sum b_{(1,c)(a,1)} \otimes b_{(1,c)(a,2)} \otimes b_{(2,c)} &= \sum b_{(a,1)} \otimes b_{(a,2)(1,c)} \otimes b_{(a,2)(2,c)}\end{aligned}$$

However, for the sake of simplicity, we will opt for the former notation, continuously keeping track to ensure enough factors are covered.

In Section 5.5, we need to rely on the theory of multiplier Hopf algebras, in particular on the dual of a (possibly non finitely generated) k -projective Hopf algebra. We will assume the Hopf algebra has a (left) integral, i.e. there exists a map $\varphi : H \rightarrow k$ such that $\sum h_1 \varphi(h_2) = \varphi(h)1$ for all $h \in H$. The notion of an integral also exists in the multiplier Hopf algebra case.

Definition 5.2.5. A k -linear map $\varphi : A \rightarrow k$ is called a *left integral* if $(A \otimes \varphi)\Delta(a) = \varphi(a)1$ for all $a \in A$. Similarly, we can define *right integrals*. A regular multiplier Hopf algebra with an integral is called an *algebraic quantum group*.

Example 5.2.6. Consider Example 5.2.4 again, then $\varphi(f) = \sum_{p \in G} f(p)$, where $f \in A$, defines a left (and right) integral on A .

Unlike in the field case, the unicity of a left integral (if it exists) is no longer automatically fulfilled if we work over a commutative ring. Also, the construction of the dual space, relies on the fact that the integral is surjective as well. However, if we assume both conditions, the proofs in the field case can be copied nearly verbatim. We summarize the needed results in their appropriate form when working over a commutative ring. For the analogues in the field case, we refer to [81, 35, 90].

Proposition 5.2.7. *Let H be a projective Hopf algebra over the commutative ring k . Furthermore, assume there exists a left integral $\varphi : H \rightarrow k$ which is faithful (i.e. $\varphi(h-) = 0$ or $\varphi(-h) = 0$ implies $h = 0$) and surjective, then we have the following:*

- *The integral space is generated by φ .*
- *One can define a dual \hat{H} , which is a multiplier Hopf algebra with integral. As a k -module, \hat{H} is equal to*

$$\begin{aligned}\{\varphi(a-) \mid a \in H\} \\ \{\varphi(-a) \mid a \in H\} \\ \{\psi(a-) \mid a \in H\} \\ \{\psi(-a) \mid a \in H\}\end{aligned}$$

where ψ is a faithful and surjective right integral (e.g. $\psi = \varphi \circ S$). The multiplication and comultiplication are given by

$$\begin{aligned}(\omega v)(x) &= (\omega \otimes v)\Delta(x) \\ ((\omega \otimes 1)\hat{\Delta}(v))(x \otimes y) &= (\omega \otimes v)(\Delta(x)(1 \otimes y)) \\ (\hat{\Delta}(\omega)(1 \otimes v))(x \otimes y) &= (\omega \otimes v)((x \otimes 1)\Delta(y))\end{aligned}$$

for $\omega, v \in \hat{H}$ and $x, y \in H$. The counit $\hat{\epsilon}$ is given by evaluation in 1 whereas the antipode \hat{S} is dual to S . The integral $\hat{\varphi}$ is defined by

$$\hat{\varphi}(\omega) = \epsilon(a)$$

where $\omega = \psi(a-)$.

- As $\hat{\varphi}$ is faithful and surjective too, one can construct $\hat{\hat{H}}$, which is isomorphic to H .
- There exists a 'dual basis', i.e. an element

$$u \otimes v = \sum \hat{\varphi}(-\varphi_2) \otimes \hat{S}^{-1}(\varphi_1) \in M(H \otimes \hat{H})$$

which satisfies

- (1) $v(\hat{h}, u) = \hat{h}$ for $\hat{h} \in \hat{H}$
 $u(v, h) = h$ for $h \in H$
- (2) $(\Delta_H \otimes \hat{H})(u \otimes v) = u \otimes u' \otimes vv' \in M(H \otimes H \otimes \hat{H})$
- (3) $(H \otimes \hat{\Delta})(u \otimes v) = uu' \otimes v \otimes v' \in M(H \otimes \hat{H} \otimes \hat{H})$.

5.3 Constructing Galois objects from Azumaya algebras

For the remainder of this chapter, we will assume H to be k -projective and cocommutative, although some results and lemmas are still valid without this assumption. For the sake of generality we still denote S^{-1} on occasion (even though $S^{-1} = S$).

Let A be an H -module algebra. Let us denote $S_A = A\#H$. Then

$$(a\#g)(b\#h) = \sum a(g_1 \cdot b)\#g_2h$$

for $a, b \in A$ and $g, h \in H$. We can identify A with the subalgebra $A\#1$.

If A is a unital k -algebra, then S_A is a unital A^e -module, with left module action given by

$$(a \otimes a') \cdot (b\#h) = \sum ab(h_1 \cdot a')\#h_2$$

for $a, a', b \in A$ and $h \in H$. Since A is unital, b can be written as a sum $b = \sum_i x_i y_i z_i \in A^3$. One can easily verify

$$b\#h = \sum (x_i \otimes S^{-1}(h_1) \cdot z_i) \cdot (y_i\#h_2) \in A^e \cdot A\#H$$

Note that the embedding $A \rightarrow S_A : a \mapsto a\#1$ becomes a left A^e -module map. S_A is an H -comodule algebra, with H -comodule structure defined by

$$\rho_{S_A} : S_A \rightarrow S_A \otimes H, \rho_{S_A}(a\#h) = \sum a\#h_1 \otimes h_2$$

Furthermore, ρ_{S_A} is A^e -linear and S_A becomes an H -Galois extension.

Lemma 5.3.1. *S_A/A is an H -Galois extension.*

Proof. As the H -comodule structure on S_A is given by $A \otimes \Delta$, we immediately have

$$(S_A)^{coH} = A\#1 \cong A$$

The canonical map is of the following form

$$\begin{aligned} can_{S_A} : S_A \otimes_A S_A &\rightarrow S_A \otimes H, \\ can_{S_A}(b\#g \otimes_A c\#h) &= \sum b(g_1 \cdot c)\#g_2 h_1 \otimes h_2 \end{aligned}$$

The reader can easily verify that can_{S_A} is bijective with inverse given by

$$\begin{aligned} \xi : S_A \otimes H &\rightarrow S_A \otimes_A S_A, \\ \xi(bc\#g \otimes h) &= \sum (b\#g_2 S(h_1)) \otimes_A ((h_2 S^{-1}(g_1)) \cdot c\#h_3) \end{aligned}$$

ξ is well defined since A is unital. □

Denote by $\pi(A)$ the centralizer of A in the unital algebra $M(S_A)$. $\pi(A)$ is a sub-algebra with identity. S_A is a unital A^e -module, hence we can consider the k -module $Hom_{A^e}(A, S_A)$. We show that $\pi(A)$ can be identified with this k -module $Hom_{A^e}(A, S_A)$ (for an H -Taylor-Azumaya algebra A).

Lemma 5.3.2. *Let A be an H -module Taylor-Azumaya algebra, then $\pi(A) \cong Hom_{A^e}(A, S_A)$ as algebras.*

Proof. $Hom_{A^e}(A, S_A)$ is a k -algebra with multiplication given by

$$(ff')(ab) = f(a)f'(b)$$

for $f, f' \in Hom_{A^e}(A, S_A)$ and $a, b \in A$. This product is well defined since $A \otimes_A A \cong A$ (A is unital). The unit is given by the embedding $A \rightarrow S_A, a \mapsto a\#1_H$.

Let $x \in M(S_A)$, say $x = (\rho_1, \rho_2)$. ρ_1 is right S_A -linear (by definition), in particular ρ_1 is right A -linear. Similar, ρ_2 is left A -linear. However, we see that $x \in \pi(A) =$

$C_{M(S_A)}(A)$ if and only if ρ_1 is left A -linear as well and ρ_2 is right A -linear too. Moreover, we then have $\rho_1 = \rho_2$, indeed $\rho_1(ab) = a\rho_1(b) = \rho_2(a)b = \rho_2(ab)$. For $x \in \pi(A)$, define $f_x \in \text{Hom}_{A^e}(A, S_A)$ by

$$\begin{aligned} f_x(a) &= (a\#1)x = \rho_2(a\#1) \\ &= x(a\#1) = \rho_1(a\#1) \end{aligned}$$

Since ρ_2 is both left and right A -linear, f_x is an A -bimodule map, i.e. f_x is left A^e -linear. Hence, we have a map $\alpha : \pi(A) \rightarrow \text{Hom}_{A^e}(A, S_A)$, $\alpha(x) = f_x$. Conversely, we first note that $1\#g \in M(S_A)$ for $g \in H$, as follows

$$\begin{aligned} (1\#g)(b\#h) &= \sum (g_1 \cdot b)\#g_2h \\ (b\#h)(1\#g) &= b\#hg \end{aligned}$$

Define a map $\beta : \text{Hom}_{A^e}(A, S_A) \rightarrow \pi(A)$, $\beta(f) = (\rho_1, \rho_2)$ with

$$\begin{aligned} \rho_1(a\#g) &= f(a)(1\#g) \\ \rho_2(a\#g) &= \sum (1\#g_2)f(S^{-1}(g_1) \cdot a) \end{aligned}$$

ρ_1 is right S_A -linear since

$$\begin{aligned} &\rho_1((a\#g)(b\#h)) \\ &= \sum \rho_1(a(g_1 \cdot b)\#g_2h) \\ &= \sum f(a(g_1 \cdot b))(1\#g_2h) \\ &= \sum f(a)((g_1 \cdot b)\#1)(1\#g_2h) \\ &= \sum f(a)((g_1 \cdot b)\#g_2h) \\ &= f(a)(1\#g)(b\#h) \\ &= \rho_1(a\#g)(b\#h) \end{aligned}$$

A similar computation shows that ρ_2 is left S_A -linear.

$$\begin{aligned} &\rho_2((a\#g)(b\#h)) \\ &= \sum \rho_2(a(g_1 \cdot b)\#g_2h) \\ &= \sum (1\#g_3h_2) f(S^{-1}(g_2h_1) \cdot (a(g_1 \cdot b))) \\ &= \sum (1\#g_4h_3) f((S^{-1}(g_3h_2) \cdot a)((S^{-1}(g_2h_1)g_1) \cdot b)) \\ &= \sum (1\#g_2h_3) ((S^{-1}(g_1h_2) \cdot a)\#1) f(S^{-1}(h_1) \cdot b) \\ &= \sum (((g_2h_3S^{-1}(h_2)S^{-1}(g_1)) \cdot a)\#g_3h_4) f(S^{-1}(h_1) \cdot b) \end{aligned}$$

$$\begin{aligned}
&= \sum (a\#gh_2) f(S^{-1}(h_1) \cdot b) \\
&= \sum (a\#g)(1\#h_2)f(S^{-1}(h_1) \cdot b) \\
&= (a\#g)\rho_2(b\#h)
\end{aligned}$$

Next we compute that (ρ_1, ρ_2) is a multiplier.

$$\begin{aligned}
&(a\#g) \rho_1(b\#h) \\
&= (a\#g)f(b)(1\#h) \\
&= (1\#g_2)((S^{-1}(g_1) \cdot a)\#1)f(b)(1\#h) \\
&= (1\#g_2)f((S^{-1}(g_1) \cdot a)b)(1\#h) \\
&= (1\#g_2)f((S^{-1}(g_1) \cdot a))(b\#1)(1\#h) \\
&= (1\#g_2)f((S^{-1}(g_1) \cdot a))(b\#h) \\
&= \rho_2(a\#g) (b\#h)
\end{aligned}$$

To show that $(\rho_1, \rho_2) \in \pi(A)$, we verify that ρ_1 is left A -linear and ρ_2 is right A -linear.

$$\begin{aligned}
\rho_1(a(b\#h)) &= f(ab)(1\#h) \\
&= (af(b))(1\#h) \\
&= af(b)(1\#h) \\
&= a\rho_1(b\#h) \\
\rho_2((a\#g)b) &= \sum \rho_2(a(g_1 \cdot b)\#g_2) \\
&= \sum (1\#g_3)f(S^{-1}(g_2) \cdot (a(g_1 \cdot b))) \\
&= \sum (1\#g_4)f((S^{-1}(g_3) \cdot a)(S^{-1}(g_2) \cdot (g_1 \cdot b))) \\
&= \sum (1\#g_2)f((S^{-1}(g_1) \cdot a)b) \\
&= \sum (1\#g_2)(f(S^{-1}(g_1) \cdot a)b) \\
&= \sum (1\#g_2)f(S^{-1}(g_1) \cdot a)b \\
&= \rho_2(a\#g)b
\end{aligned}$$

Obviously, $\alpha \circ \beta = 1$. Say $\beta(\alpha(\rho_1, \rho_2)) = \beta(f) = (\rho'_1, \rho'_2)$, for $x = (\rho_1, \rho_2) \in \pi(A)$. Then

$$\begin{aligned}
\rho'_1(a\#g) &= f(a)(1\#g) \\
&= \rho_1(a\#1)(1\#g) \\
&= \rho_1((a\#1)(1\#g)) \\
&= \rho_1(a\#g)
\end{aligned}$$

and

$$\begin{aligned}
\rho'_2(a\#g) &= (1\#g_2)f(S^{-1}(g_1) \cdot a) \\
&= (1\#g_2)\rho_2((S^{-1}(g_1) \cdot a)\#1) \\
&= \rho_2((1\#g_2)((S^{-1}(g_1) \cdot a)\#1)) \\
&= \rho_2(g_2 \cdot (S^{-1}(g_1) \cdot a)\#g_3) \\
&= \rho_2(a\#g)
\end{aligned}$$

Hence, α is the inverse of β . We conclude by showing that α is an algebra map. If $\alpha(\rho_1, \rho_2) = f$ and $\alpha(\rho'_1, \rho'_2) = f'$, then

$$\begin{aligned}
\alpha((\rho_1, \rho_2)(\rho'_1, \rho'_2))(ab) &= \alpha(\rho_1 \circ \rho'_1, \rho'_2 \circ \rho_2)(ab) \\
&= (\rho'_2 \circ \rho_2)(ab\#1) \\
&= \rho'_2(\rho_2((a\#1)(b\#1))) \\
&= \rho'_2(\rho_2(a\#1)(b\#1)) \\
&= \rho_2(a\#1)\rho'_2(b\#1) \\
&= f(a)f'(b) \\
&= (ff')(ab)
\end{aligned}$$

□

Using the above lemma and the equivalence pair (F, G_l) , we obtain the following corollary.

Corollary 5.3.3. *Let A be an H -Taylor-Azumaya algebra, then*

$$A \otimes \pi(A) \cong A \otimes \text{Hom}_{A^e}(A, S_A) \cong S_A$$

The composition of these isomorphisms is just the 'multiplication' sending $a \otimes x$ to $ax = (a\#1)x$ for $a \in A$ and $x \in \pi(A)$. Moreover, it is A^e -linear and an algebra morphism.

We want to define an H -comodule structure on $\pi(A)$. We do this by defining an H -comodule structure on $\text{Hom}_{A^e}(A, S_A)$ and by using the isomorphism from Lemma 5.3.2. As A is an H -module Taylor-Azumaya algebra, the categories ${}_k\mathcal{M}$ and ${}_{A^e}\mathcal{M}^u$ are equivalent, either by the pair (F, G) or by the pair (F, G_l) , where

$$\begin{aligned}
F : {}_k\mathcal{M} &\rightarrow {}_{A^e}\mathcal{M}^u : N \mapsto A_l \otimes N \\
G : {}_{A^e}\mathcal{M}^u &\rightarrow {}_k\mathcal{M} : M \mapsto (A_r \otimes I) \otimes_{A^e} M \\
G_l : {}_{A^e}\mathcal{M}^u &\rightarrow {}_k\mathcal{M} : M \mapsto \text{Hom}_{A^e}(A, M)
\end{aligned}$$

Hence, the functors G and G_l are naturally isomorphic, say by $\alpha : G_l \rightarrow G$. As S_A is an H -comodule and the map $\rho_{S_A} : S_A \rightarrow S_A \otimes H$ is A^e -linear, we can now use this

isomorphism to define a map $\rho : \text{Hom}_{A^e}(A, S_A) \rightarrow \text{Hom}_{A^e}(A, S_A) \otimes H$ as follows

$$\begin{array}{ccc} \text{Hom}_{A^e}(A, S_A) & \xrightarrow{\alpha_{S_A}} & (A_r \otimes I) \otimes_{A^e} S_A \\ \downarrow \rho & & \downarrow (A_r \otimes I) \otimes \rho_{S_A} \\ \text{Hom}_{A^e}(A, S_A) \otimes H & \xleftarrow{\alpha_{S_A}^{-1} \otimes H} & (A_r \otimes I) \otimes_{A^e} S_A \otimes H \end{array}$$

Moreover, since $A_l \otimes -$ is an equivalence, the map $\rho : \text{Hom}_{A^e}(A, S_A) \rightarrow \text{Hom}_{A^e}(A, S_A) \otimes H$ is completely determined by $A \otimes \rho$. By definition of ρ , ρ satisfies the following diagram

$$\begin{array}{ccc} A \otimes \text{Hom}_{A^e}(A, S_A) & \xrightarrow{ev_{S_A}} & S_A \\ \downarrow A \otimes \rho & & \downarrow \rho_{S_A} \\ A \otimes \text{Hom}_{A^e}(A, S_A) \otimes H & \xrightarrow{ev_{S_A} \otimes H} & S_A \otimes H \end{array}$$

Thus, if we make use of Sweedler notation and denote $\rho(f) = \sum f_{(0)} \otimes f_{(1)}$, for $f \in \text{Hom}_{A^e}(A, S_A)$, we have

$$\sum f_{(0)}(a) \otimes f_{(1)} = \sum f(a)_{(0)} \otimes f(a)_{(1)} \quad (5.3.1)$$

for all $a \in A$. Moreover, the element $\sum f_{(0)} \otimes f_{(1)} \in \text{Hom}_{A^e}(A, S_A) \otimes H$ is uniquely determined by this equation. I.e. suppose there exists $\sum g_j \otimes h_j \in \text{Hom}_{A^e}(A, S_A) \otimes H$ such that $\sum g_j(a) \otimes h_j = \sum f(a)_{(0)} \otimes f(a)_{(1)}$ for all $a \in A$, then $\rho(f) = \sum g_j \otimes h_j$. This is a result of the following lemma.

Lemma 5.3.4. *The natural map $\sigma : \text{Hom}_{A^e}(A, S_A) \otimes H \rightarrow \text{Hom}_{A^e}(A, S_A \otimes H)$ is an isomorphism of k -modules.*

Proof. To be more specific, σ is defined as follows

$$\begin{aligned} \sigma : \text{Hom}_{A^e}(A, S_A) \otimes H &\rightarrow \text{Hom}_{A^e}(A, S_A \otimes H) \\ f \otimes h &\mapsto (a \mapsto f(a) \otimes h) \end{aligned}$$

Since $A \otimes -$ is an equivalence functor, it is sufficient to note that $A \otimes \sigma$ is an isomorphism of unital A^e -modules. The latter can easily be seen by the commutativity of the following diagram

$$\begin{array}{ccc} A \otimes \text{Hom}_{A^e}(A, S_A) \otimes H & \xrightarrow{A \otimes \sigma} & A \otimes \text{Hom}_{A^e}(A, S_A \otimes H) \\ \downarrow ev_{S_A} \otimes H & & \downarrow ev_{S_A \otimes H} \\ S_A \otimes H & \xrightarrow{id} & S_A \otimes H \end{array}$$

where ev denotes the counit of the equivalence pair (F, G_l) . Recall that ev_N is an A^e -linear isomorphism for any unital A^e -module N . \square

In particular, if we have elements $f_i, g_j \in Hom_{A^e}(A, S_A)$ and $h_i, l_j \in H$ such that $\sum_i f_i(a) \otimes h_i = \sum_j g_j(a) \otimes l_j$ for all $a \in A$, then $\sum_i f_i \otimes h_i = \sum_j g_j \otimes l_j$.

Lemma 5.3.5. *The map $\rho : Hom_{A^e}(A, S_A) \rightarrow Hom_{A^e}(A, S_A) \otimes H$ defines an H -comodule structure on $Hom_{A^e}(A, S_A)$. Moreover, $Hom_{A^e}(A, S_A)$ is an H -comodule algebra.*

Proof. Again, to prove the equality $\rho \otimes id \circ \rho = id \otimes \Delta \circ \rho$, it suffices to verify that $A \otimes \rho \otimes id \circ A \otimes \rho = A \otimes id \otimes \Delta \circ A \otimes \rho$ holds. This equality is equivalent to the commutativity of the following diagram

$$\begin{array}{ccc}
A \otimes Hom_{A^e}(A, S_A) & \xrightarrow{ev_{S_A}} & S_A \\
\downarrow A \otimes \rho & & \downarrow \rho_{S_A} \\
A \otimes Hom_{A^e}(A, S_A) \otimes H & \xrightarrow{ev_{S_A} \otimes H} & S_A \otimes H \\
\downarrow A \otimes \rho \otimes H & \downarrow A \otimes id \otimes \Delta & \downarrow \rho_{S_A} \otimes H \quad \downarrow S_A \otimes \Delta \\
A \otimes Hom_{A^e}(A, S_A) \otimes H \otimes H & \xrightarrow{ev_{S_A} \otimes H \otimes H} & S_A \otimes H \otimes H
\end{array}$$

Or, using Sweedler notation, we have

$$\begin{aligned}
f_{(0)(0)}(a) \otimes f_{(0)(1)} \otimes f_{(1)} &= f(a)_{(0)(0)} \otimes f(a)_{(0)(1)} \otimes f(a)_{(1)} \\
&= f(a)_{(0)} \otimes f(a)_{(1)(1)} \otimes f(a)_{(1)(2)} \\
&= f_{(0)}(a) \otimes f_{(1)(1)} \otimes f_{(1)(2)}
\end{aligned}$$

for all $a \in A$, implying $\rho \otimes id \circ \rho(f) = id \otimes \Delta \circ \rho(f)$ for all $f \in Hom_{A^e}(A, S_A)$.

We leave the verification of the counit condition to the reader.

To show that $Hom_{A^e}(A, S_A)$ is an H -comodule algebra, i.e. $(fg)_{(0)} \otimes (fg)_{(1)} = f_{(0)}g_{(0)} \otimes f_{(1)}g_{(1)}$ for all $f, g \in Hom_{A^e}(A, S_A)$, we again make use of the injectivity of the map $\sigma : Hom_{A^e}(A, S_A) \otimes H \rightarrow Hom_{A^e}(A, S_A \otimes H)$. The algebra structure of $Hom_{A^e}(A, S_A)$ is described in Lemma 5.3.2. Using the fact that A is unital, we have

$$\begin{aligned}
(fg)_{(0)}(ab) \otimes (fg)_{(1)} &= (fg)(ab)_{(0)} \otimes (fg)(ab)_{(1)} \\
&= (f(a)g(b))_{(0)} \otimes (f(a)g(b))_{(1)} \\
&= f(a)_{(0)}g(b)_{(0)} \otimes f(a)_{(1)}g(b)_{(1)} \\
&= f_{(0)}(a)g_{(0)}(b) \otimes f_{(1)}g_{(1)} \\
&= (f_{(0)}g_{(0)})(ab) \otimes f_{(1)}g_{(1)}
\end{aligned}$$

showing $(fg)_{(0)} \otimes (fg)_{(1)} = f_{(0)}g_{(0)} \otimes f_{(1)}g_{(1)}$. Also

$$\begin{aligned} \eta_{(0)}(a) \otimes \eta_{(1)} &= \eta(a)_{(0)} \otimes \eta(a)_{(1)} \\ &= a\#1 \otimes 1 \\ &= \eta(a) \otimes 1 \end{aligned}$$

for all $a \in A$, hence $\rho(\eta) = \eta \otimes 1$. \square

Later on, it will be more convenient to work with $\pi(A)$. Therefore, we will use the isomorphism in Lemma 5.3.2 to define an H -comodule structure on $\pi(A)$, again denoted by $\rho(x) = \sum x_{(0)} \otimes x_{(1)}$ for $x \in \pi(A)$. In view of Lemma 5.3.2 and Lemma 5.3.4 (or equation (5.3.1)), one can consider $\sum x_{(0)} \otimes x_{(1)}$ to be the unique element obeying

$$\sum x_{(0)}a \otimes x_{(1)} = \sum (xa)_{(0)} \otimes (xa)_{(1)} \quad (5.3.2)$$

for all $a \in A$. Actually, we have shown

Lemma 5.3.6. *Let A be an H -module Taylor-Azumaya algebra, then $\pi(A)$ is an H -comodule algebra.*

Remark 5.3.7. It follows directly from (5.3.2) that the isomorphism $A \otimes \pi(A) \cong S_A$ from Corollary 5.3.3 is now an A^e -linear isomorphism of H -comodule algebras.

Lemma 5.3.8. *Let A be an H -Taylor-Azumaya algebra. Then $\pi(A)$ is an H -Galois extension of k .*

Proof. We have $A \otimes \pi(A) \cong S_A$ as H -comodule algebras. By taking the H -coinvariants, we see

$$A \otimes \pi(A)^{coH} = (A \otimes \pi(A))^{coH} \cong S_A^{coH} = A \otimes k$$

As $(F = A_l \otimes -, G_l)$ is an equivalence, we obtain $\pi(A)^{coH} = k$.

Next we have to prove that $can : \pi(A) \otimes \pi(A) \rightarrow \pi(A) \otimes H : x \otimes y \mapsto \sum xy_{(0)} \otimes y_{(1)}$ is an isomorphism. Because of the equivalence (F, G_l) , it suffices to show that $A \otimes can : A \otimes \pi(A) \otimes \pi(A) \rightarrow A \otimes \pi(A) \otimes H$ is an isomorphism.

S_A is a unital A^e -module, hence a unital A -bimodule. In particular S_A is a right unital A -module, or $S_A \cong S_A \otimes_A A$. Define α as the composition of the following isomorphisms

$$A \otimes \pi(A) \otimes \pi(A) \cong S_A \otimes \pi(A) \cong S_A \otimes_A A \otimes \pi(A) \cong S_A \otimes_A S_A$$

Let $a \otimes x \otimes y \in A \otimes \pi(A) \otimes \pi(A)$, then $\alpha(a \otimes x \otimes y) = \sum x_i \otimes_A a_i y$, where $\sum x_i a_i = ax \in S_A$. The following diagram commutes

$$\begin{array}{ccc} A \otimes \pi(A) \otimes \pi(A) & \xrightarrow{A \otimes can} & A \otimes \pi(A) \otimes H \\ \alpha \downarrow & & \downarrow \mu \otimes H \\ S_A \otimes_A S_A & \xrightarrow{can_{S_A}} & S_A \otimes H \end{array}$$

where $\text{can}_{S_A}(b\#g \otimes_A c\#h) = \sum b(g_1 \cdot c)\#g_2h_1 \otimes h_2$ as in Lemma 5.3.1. Indeed

$$\begin{aligned} (\mu \otimes H)((A \otimes \text{can})(a \otimes x \otimes y)) &= \sum (\mu \otimes H)(a \otimes xy_{(0)} \otimes y_{(1)}) \\ &= \sum axy_{(0)} \otimes y_{(1)} \end{aligned}$$

and

$$\begin{aligned} \text{can}_{S_A}(\alpha(a \otimes x \otimes y)) &= \text{can}_{S_A}\left(\sum x_i \otimes_A a_i y\right) \\ &= \sum x_i (a_i y)_{(0)} \otimes (a_i y)_{(1)} \\ &= \sum x_i a_i y_{(0)} \otimes y_{(1)} && \text{by (5.3.2)} \\ &= \sum axy_{(0)} \otimes y_{(1)} \end{aligned}$$

The maps α , $\mu \otimes H$ and can_{S_A} are isomorphisms, showing that $A \otimes \text{can}$, and hence can , is an isomorphism as well. Thus $\pi(A)$ is an H -Galois extension. \square

For $\pi(A)$ to be flat, it seems that we have to require that the Taylor-Azumaya algebra A is flat as a k -module.

Lemma 5.3.9. *Let A be an H -Taylor-Azumaya algebra which is flat as a k -module. Then $\pi(A)$ is flat.*

Proof. Let $f : M \rightarrow N$ be an injective k -module map. We have to show that $\pi(A) \otimes f : \pi(A) \otimes M \rightarrow \pi(A) \otimes N$ is injective too. A being a Taylor-Azumaya algebra, we have a pair of inverse equivalences

$$(F(-) = A_l \otimes -, G_l(-) = \text{Hom}_{A^e}(A, -))$$

In particular, $\pi(A) \otimes f$ is injective (monic in ${}_k\mathcal{M}$) if and only if $A \otimes \pi(A) \otimes f$ is a monomorphism in ${}_{A^e}\mathcal{M}^u$. In view of Corollary 5.3.3, it suffices to prove that $S_A \otimes f : S_A \otimes M \rightarrow S_A \otimes N$ is a monomorphism in ${}_{A^e}\mathcal{M}^u$.

Note that $S_A = A \otimes H$ as a k -module. As A is assumed to be flat (H is too), S_A is flat as a k -module. Thus $S_A \otimes f$ is injective. Consider the forgetful functor $U : {}_{A^e}\mathcal{M}^u \rightarrow {}_k\mathcal{M}$, which is a faithful functor. As $U(S_A \otimes f)$ is injective, $S_A \otimes f$ must be a monomorphism in ${}_{A^e}\mathcal{M}^u$, proving that $\pi(A)$ is flat. \square

Hence we have proved

Lemma 5.3.10. *Let A be an H -Taylor-Azumaya algebra which is flat as a k -module. Then $\pi(A)$ is an H -Galois object.*

Definition 5.3.11. Let H be a Hopf algebra and A a unital k -algebra. An H -action on A is called *strongly inner* if there exists an algebra morphism $f : H \rightarrow M(A)$ such that

$$h \cdot a = \sum f(h_1)af(S(h_2))$$

for $h \in H$ and $a \in A$.

Lemma 5.3.12. *Let $\underline{M} = (M, M', \mu)$ be a dual pair of H -modules. The induced H -action on the elementary algebra $E_k(\underline{M})$ is strongly inner. Conversely, suppose $\underline{M} = (M, M', \mu)$ is a dual pair of modules such that H acts strongly inner on the elementary algebra $E_k(\underline{M})$, then there is an H -module structure on M and M' such that the H -action on $E_k(\underline{M})$ is induced by this action on \underline{M} .*

Proof. Let $\underline{M} = (M, M', \mu)$ be a dual pair of H -modules. The induced H -action on the associated elementary algebra, say $E = E_k(\underline{M}) = M \otimes M'$, is given by

$$h \cdot (m \otimes m') = \sum h_1 \cdot m \otimes h_2 \cdot m'$$

for $h \in H$, $m \in M$ and $m' \in M'$. μ is H -linear, i.e.

$$\sum \mu(h_1 \cdot m' \otimes h_2 \cdot m) = \epsilon(h)\mu(m' \otimes m)$$

Recall the characterisation for multipliers on E :

$$M(E) \cong \bar{E} = \{(f, f') \in E_1 \times E_2 \mid \mu(m' \otimes f(m)) = \mu(f'(m') \otimes m), \forall m \in M, m' \in M'\}$$

where $E_1 = \text{End}(M)$ and $E_2 = \text{End}(M')^{\text{op}}$. Let

$$\begin{aligned} \rho : H &\rightarrow E_1, \rho_M(h)(m) = h \cdot m \\ \rho' : H &\rightarrow E_2, \rho_{M'}(h)(m') = S^{-1}(h) \cdot m' \end{aligned}$$

be representations of the H -action on M respectively M' .

$$\begin{aligned} \mu(\rho'(h)(m') \otimes m) &= \mu(S^{-1}(h) \cdot m' \otimes m) \\ &= \sum \mu(S^{-1}(h_3) \cdot m' \otimes (S^{-1}(h_2)h_1) \cdot m) \\ &= \sum \epsilon(S^{-1}(h_2))\mu(m' \otimes h_1 \cdot m) \\ &= \mu(m' \otimes h \cdot m) \\ &= \mu(m' \otimes \rho(h)(m)) \end{aligned}$$

for $h \in H$, $m \in M$ and $m' \in M'$, such that $(\rho(h), \rho'(h)) \in M(E)$. Define $f : H \rightarrow M(E)$, $f(h) = (\rho(h), \rho'(h))$. Then

$$\begin{aligned} h \cdot (m \otimes m') &= \sum h_1 \cdot m \otimes h_2 \cdot m' \\ &= \sum \rho(h_1)(m) \otimes \rho'(S(h_2))(m') \\ &= \sum (\rho(h_1), \rho'(h_1))(m \otimes m')(\rho(S(h_2)), \rho'(S(h_2))) \\ &= \sum f(h_1)(m \otimes m')f(S(h_2)) \end{aligned}$$

by the identification in Proposition 5.2.1. Moreover, f is an algebra map

$$\begin{aligned} f(h)f(h') &= (\rho(h), \rho'(h))(\rho(h'), \rho'(h')) = (\rho(h) \circ \rho(h'), \rho'(h') \circ \rho'(h)) \\ &= (\rho(hh'), \rho'(hh')) = f(hh') \\ f(1_H) &= (\rho(1_H), \rho'(1_H)) = (id_M, id_{M'}) \end{aligned}$$

for $h, h' \in H$. Thus, the H -action on E is strongly inner.

Conversely, suppose there exists an H -action on E which is strongly inner, i.e. there is an algebra morphism $\lambda : H \rightarrow M(E)$. Under the identification $M(E) \cong \overline{E}$, we can see λ as a map

$$\lambda : H \rightarrow \overline{E} : h \mapsto (\rho(h), \rho'(h))$$

such that

$$\begin{aligned} h \cdot (m \otimes m') &= \sum \lambda(h_1)(m \otimes m')\lambda(S(h_2)) \\ &= \sum \rho(h_1)(m) \otimes \rho'(S(h_2))(m') \end{aligned} \tag{5.3.3}$$

for $h \in H$, $m \in M$ and $m' \in M'$.

Define an H -action on M respectively M' by $h \cdot m = \rho(h)(m)$ respectively $h \cdot m' = \rho'(S(h))(m')$. Then (5.3.3) becomes

$$h \cdot (m \otimes m') = \sum h_1 \cdot m \otimes h_2 \cdot m'$$

Hence, the H -action on E is induced by the actions on M and M' . Finally, we verify that μ is H -linear.

$$\begin{aligned} \mu(h \cdot (m' \otimes m)) &= \sum \mu(h_1 \cdot m' \otimes h_2 \cdot m) \\ &= \sum \mu(\rho'(h_1)(m') \otimes \rho(S(h_2))(m)) \\ &= \sum \mu(m' \otimes \rho(h_1)\rho(S(h_2))(m)) \\ &= \sum \mu(m' \otimes \rho(h_1 S(h_2))(m)) \\ &= \mu(m' \otimes \epsilon(h)\rho(1_H)(m)) \\ &= \epsilon(h)\mu(m' \otimes m) \end{aligned}$$

for $h \in H$, $m \in M$ and $m' \in M'$. Thus $\underline{M} = (M, M', \mu)$ is a dual pair of H -modules. \square

Lemma 5.3.13. *Let A be an H -Taylor-Azumaya algebra. The H -action on A is strongly inner if and only if $\pi(A) \cong H$ as H -comodule algebras.*

Proof. First suppose the H -action on A is strongly inner. I.e. there exists an algebra morphism $f : H \rightarrow M(A)$ such that $h \cdot a = \sum f(h_1)af(S(h_2))$. Under these circumstances, $A \otimes H \cong A\#H$ as H -comodule algebras. Indeed, a straight forward computation shows that

$$\alpha : A \otimes H \rightarrow A\#H : a \otimes h \mapsto \sum af(S(h_1))\#h_2$$

is bijective with inverse given by

$$\beta : A\#H \rightarrow A \otimes H : a\#h \mapsto \sum af(h_1) \otimes h_2$$

Obviously, α is an H -comodule morphism. Finally, since the H -action is strongly inner, α is an algebra map as well, indeed

$$\begin{aligned} & \alpha(a \otimes h)\alpha(b \otimes g) \\ &= \sum (af(S(h_1))\#h_2)(bf(S(g_1))\#g_2) \\ &= \sum af(S(h_1))(h_2 \cdot (bf(S(g_1))))\#h_3g_2 \\ &= \sum af(S(h_1))f(h_2)(bf(S(g_1)))f(S(h_3))\#h_4g_2 \\ &= \sum af(S(h_1)h_2)(bf(S(g_1)))f(S(h_3))\#h_4g_2 \\ &= \sum abf(S(g_1))f(S(h_1))\#h_2g_2 \\ &= \sum abf(S(h_1g_1))\#h_2g_2 \\ &= \alpha(ab \otimes hg) \\ &= \alpha((a \otimes h)(b \otimes g)) \end{aligned}$$

Thus $A \otimes H \cong A\#H$ as H -comodule algebras. But also $A \otimes \pi(A) \cong A\#H$ as H -comodule algebras, hence $A \otimes H \cong A \otimes \pi(A)$ as H -comodule algebras. Since A is an H -Taylor-Azumaya algebra, one can make use of the equivalence pair $(F(-) = A_l \otimes -, G_l(-) = Hom_{A^e}(A, -))$ to conclude $H \cong \pi(A)$ as H -comodule algebras.

To prove the converse, we need the following lemma.

Lemma 5.3.14. *There exists an anti algebra morphism*

$$p : \pi(A) \rightarrow M(A)$$

Proof. Define $p : \pi(A) \rightarrow M(A) : x \mapsto (\lambda_x, \rho_x)$ with

$$\begin{aligned} \lambda_x(a) &= (\iota \otimes \epsilon)\left(\sum x_{(0)}(S(x_{(1)}) \cdot a)\right) \\ \rho_x(a) &= (\iota \otimes \epsilon)(ax) \end{aligned}$$

for $a \in A$, where we have denoted the identity on A by ι , i.e. $\iota \otimes \epsilon : A \# H \rightarrow A$, $(\iota \otimes \epsilon)(a \# h) = a\epsilon(h)$. $\iota \otimes \epsilon$ is obviously left A -linear, $\iota \otimes \epsilon$ is not right A -linear, however we do have

$$\begin{aligned} (\iota \otimes \epsilon)(a \# h)b &= \sum (\iota \otimes \epsilon)((a \# h_1)(S(h_2) \cdot b)) \\ &= \sum (\iota \otimes \epsilon)((a \# h)_{(0)}(S((a \# h)_{(1)}) \cdot b)) \end{aligned}$$

since H is cocommutative. Hence for $x \in \pi(A)$

$$\begin{aligned} (\iota \otimes \epsilon)(xa)b &= \sum (\iota \otimes \epsilon)((xa)_{(0)}(S((xa)_{(1)}) \cdot b)) \\ &= \sum (\iota \otimes \epsilon)((x_{(0)}a)(S(x_{(1)}) \cdot b)) \end{aligned} \tag{5.3.4}$$

Also, for $a, b \in A$ and $h, g \in H$,

$$(\iota \otimes \epsilon)((a \# h)(\iota \otimes \epsilon)(b \# g)) = (\iota \otimes \epsilon)((a \# h)(b \# g)) \tag{5.3.5}$$

To verify that $p(x) = (\lambda_x, \rho_x)$ is a multiplier, take $a, b \in A$. Then

$$\begin{aligned} a\lambda_x(b) &= \sum a(\iota \otimes \epsilon)(x_{(0)}(S(x_{(1)}) \cdot b)) \\ &= \sum (\iota \otimes \epsilon)(a(x_{(0)}(S(x_{(1)}) \cdot b))) \\ &= \sum (\iota \otimes \epsilon)((ax)_{(0)}(S(x_{(1)}) \cdot b)) \\ &= \sum (\iota \otimes \epsilon)((ax)_{(0)}(S((ax)_{(1)}) \cdot b)) \\ &= \sum (\iota \otimes \epsilon)(ax)b && \text{by (5.3.4)} \\ &= \rho_x(a)b \end{aligned}$$

Furthermore, p is an anti algebra morphism. Indeed, let $x, y \in \pi(A)$, we show: $(\lambda_{yx}, \rho_{yx}) = p(yx) = p(x)p(y) = (\lambda_x \circ \lambda_y, \rho_y \circ \rho_x)$. Let $a, b \in A$, then

$$\begin{aligned} \rho_y(\rho_x(ab)) &= (\iota \otimes \epsilon)(y((\iota \otimes \epsilon)(x(ab)))) \\ &= (\iota \otimes \epsilon)((ya)(\iota \otimes \epsilon)(xb)) \\ &= (\iota \otimes \epsilon)((ya)(xb)) && \text{by (5.3.5)} \\ &= (\iota \otimes \epsilon)((yx)(ab)) \\ &= \rho_{yx}(ab) \end{aligned}$$

Moreover

$$\begin{aligned}
& \lambda_x(\lambda_y(ab)) \\
&= \sum \lambda_x((\iota \otimes \epsilon)(y_{(0)}(S(y_{(1)}) \cdot (ab)))) \\
&= \sum (\iota \otimes \epsilon)\left(x_{(0)}(S(x_{(1)}) \cdot (\iota \otimes \epsilon)(y_{(0)}(S(y_{(1)}) \cdot (ab))))\right) \\
&= \sum (\iota \otimes \epsilon)\left(x_{(0)}(S(x_{(1)}) \cdot (\iota \otimes \epsilon)(y_{(0)}((S(y_{(2)}) \cdot a)(S(y_{(1)}) \cdot b))))\right) \\
&= \sum (\iota \otimes \epsilon)\left(x_{(0)}(S(x_{(1)}) \cdot ((S(y_{(2)}) \cdot a)(\iota \otimes \epsilon)(y_{(0)}(S(y_{(1)}) \cdot b))))\right) \\
&= \sum (\iota \otimes \epsilon)\left(x_{(0)}((S(x_{(2)})S(y_{(2)}) \cdot a)(S(x_{(1)}) \cdot (\iota \otimes \epsilon)(y_{(0)}(S(y_{(1)}) \cdot b))))\right) \\
&= \sum (\iota \otimes \epsilon)(x_{(0)}(S(x_{(1)})S(y_{(2)}) \cdot a))(\iota \otimes \epsilon)(y_{(0)}(S(y_{(1)}) \cdot b)) \quad \text{by (5.3.4)} \\
& \\
&= \sum (\iota \otimes \epsilon)\left((\iota \otimes \epsilon)(x_{(0)}(S(x_{(1)})S(y_{(2)}) \cdot a))y_{(0)}(S(y_{(1)}) \cdot b)\right) \\
&= \sum (\iota \otimes \epsilon)\left(y_{(0)}((\iota \otimes \epsilon)(x_{(0)}(S(x_{(1)})S(y_{(2)}) \cdot a))(S(y_{(1)}) \cdot b)\right) \\
&= \sum (\iota \otimes \epsilon)\left(y_{(0)}((\iota \otimes \epsilon)(x_{(0)}(S(x_{(2)})S(y_{(2)}) \cdot a)(S(x_{(1)})S(y_{(1)}) \cdot b))\right) \quad \text{by (5.3.4)} \\
&= \sum (\iota \otimes \epsilon)\left(y_{(0)}((\iota \otimes \epsilon)(x_{(0)}(S(y_{(2)}x_{(2)}) \cdot a)(S(y_{(1)}x_{(1)}) \cdot b))\right) \\
&= \sum (\iota \otimes \epsilon)\left(y_{(0)}((S(y_{(2)}x_{(2)}) \cdot a)(\iota \otimes \epsilon)(x_{(0)}(S(y_{(1)}x_{(1)}) \cdot b))\right) \\
&= \sum (\iota \otimes \epsilon)\left(y_{(0)}((S(y_{(2)}x_{(2)}) \cdot a)(x_{(0)}(S(y_{(1)}x_{(1)}) \cdot b))\right) \quad \text{by (5.3.5)} \\
&= \sum (\iota \otimes \epsilon)\left((y_{(0)}x_{(0)})((S(y_{(2)}x_{(2)}) \cdot a)(S(y_{(1)}x_{(1)}) \cdot b)\right) \\
&= \sum (\iota \otimes \epsilon)\left((y_{(0)}x_{(0)})((S(y_{(1)}x_{(1)}) \cdot (ab))\right) \\
&= \lambda_{yx}(ab)
\end{aligned}$$

□

Now suppose $\eta : H \rightarrow \pi(A)$ is an isomorphism of H -comodule algebras. Consider the anti algebra map $p : \pi(A) \rightarrow M(A)$ from Lemma 5.3.14. Composition gives us an anti algebra morphism, say

$$f' : H \xrightarrow{\eta} \pi(A) \xrightarrow{p} M(A)$$

Define the algebra morphism

$$f : H \rightarrow M(A), \quad f(h) = f'(S(h))$$

We claim that $\sum f(h_1)af(S(h_2)) = h \cdot a$ for all $a \in A$ and $h \in H$. By definition, we have

$$\begin{aligned}
f'(S(h))a &= p(\eta(S(h))a) \\
&= \sum (\iota \otimes \epsilon)(\eta(S(h))_{(0)}(S(\eta(S(h)))_{(1)} \cdot a)) \\
&= \sum (\iota \otimes \epsilon)(\eta(S(h)_1)(S(S(h)_2) \cdot a)) \\
&= \sum (\iota \otimes \epsilon)(\eta(S(h_2))(S(S(h_1)) \cdot a)) \\
&= \sum (\iota \otimes \epsilon)(\eta(S(h_2))(h_1 \cdot a)) \\
af'(h) &= ap(\eta(h)) \\
&= (\iota \otimes \epsilon)(\eta(h)a)
\end{aligned}$$

for $a \in A$ and $h \in H$, such that

$$\begin{aligned}
&\sum f(h_1)af(S(h_2)) \\
&= \sum f'(S(h_1))af'(h_2) \\
&= \sum (\iota \otimes \epsilon)(\eta(h_3)(\iota \otimes \epsilon)(\eta(S(h_2))(h_1 \cdot a))) \\
&= \sum (\iota \otimes \epsilon)(\eta(h_3)(\eta(S(h_2))(h_1 \cdot a))) \tag{*} \\
&= \sum (\iota \otimes \epsilon)(\eta(h_3S(h_2))(h_1 \cdot a)) \\
&= (\iota \otimes \epsilon)(h \cdot a\#1) \\
&= h \cdot a
\end{aligned}$$

since $h \cdot a \in A$. We explain (*), denote $yb = \sum_j b_j\#g_j \in A\#H$, then

$$\begin{aligned}
(\iota \otimes \epsilon)(y(\iota \otimes \epsilon)(b\#g)) &= (\iota \otimes \epsilon)(yb\epsilon(g)) \\
&= \sum b_j\epsilon(g_j)\epsilon(g)
\end{aligned}$$

while

$$\begin{aligned}
(\iota \otimes \epsilon)(y(b\#g)) &= (\iota \otimes \epsilon)(y(b\#1)(1\#g)) \\
&= (\iota \otimes \epsilon)(\sum (b_j\#g_j)(1\#g)) \\
&= (\iota \otimes \epsilon)(\sum b_j\#g_jg) \\
&= \sum b_j\epsilon(g_jg) = (\iota \otimes \epsilon)(y(\iota \otimes \epsilon)(b\#g))
\end{aligned}$$

□

5.4 The group homomorphism $\tilde{\pi}$

The construction of H -Galois objects coming from (k -flat) H -Taylor-Azumaya algebras provides us with a map, say

$$\tilde{\pi} : BRM(k, H) \rightarrow Gal(k, H), \quad \tilde{\pi}([A]) = [\pi(A)]$$

Let A and B be H -Taylor-Azumaya algebras. There is an H -comodule algebra isomorphism $S_A \square_H S_B \cong S_{A \otimes B}$. This isomorphism is given by

$$\eta : S_A \square_H S_B \rightarrow S_{A \otimes B} : (a \# g) \otimes (b \# h) \mapsto (a \otimes b) \# \epsilon(g)h$$

with inverse

$$\eta^{-1} : S_{A \otimes B} \rightarrow S_A \square_H S_B : (a \otimes b) \# h \mapsto \sum (a \# h_1) \otimes (b \# h_2)$$

Indeed

$$\begin{aligned} \eta^{-1}(\eta((a \# g) \otimes (b \# h))) &= \eta^{-1}((a \otimes b) \# \epsilon(g)h) \\ &= \sum (a \# \epsilon(g)h_1) \otimes (b \# h_2) \\ &= (a \# g) \otimes (b \# h) \end{aligned}$$

where the last identity follows from the fact that $(a \# g) \otimes (b \# h)$ belongs to $S_A \square_H S_B$, in particular

$$\sum (a \# g) \otimes h_1 \otimes (b \# h_2) = \sum (a \# g_1) \otimes g_2 \otimes (b \# h)$$

If we apply $A \otimes \epsilon \otimes H \otimes B \otimes H$, we get

$$\sum a \otimes \epsilon(g)h_1 \otimes b \otimes h_2 = \sum a \otimes g \otimes b \otimes h$$

The identity $\eta \circ \eta^{-1} = 1$ is obvious. Clearly, η^{-1} is an H -comodule morphism. Moreover η^{-1} is an algebra map since

$$\begin{aligned} &\eta^{-1}(((a \otimes b) \# h)((c \otimes d) \# l)) \\ &= \sum \eta^{-1}((a \otimes b)(h_1 \cdot (c \otimes d)) \# h_2 l) \\ &= \sum \eta^{-1}((a(h_1 \cdot c) \otimes b(h_2 \cdot d)) \# h_3 l) \\ &= \sum (a(h_1 \cdot c) \# h_3 l_1) \otimes (b(h_2 \cdot d) \# h_4 l_2) \end{aligned}$$

while

$$\begin{aligned} &\eta^{-1}((a \otimes b) \# h) \eta^{-1}((c \otimes d) \# l) \\ &= \sum ((a \# h_1) \otimes (b \# h_2)) ((c \# l_1) \otimes (d \# l_2)) \\ &= \sum (a(h_1 \cdot c) \# h_2 l_1) \otimes (b(h_3 \cdot d) \# h_4 l_2) \\ &= \eta^{-1}(((a \otimes b) \# h)((c \otimes d) \# l)) \end{aligned}$$

since H is cocommutative. Thus, η^{-1} , hence η , is an H -comodule algebra isomorphism.

Lemma 5.4.1. *Let A and B be H -Taylor-Azumaya algebras. Then $\pi(A)\square_H\pi(B)$ is a subalgebra of $M(S_A\square_H S_B)$.*

Proof. We have embeddings

$$\pi(A)\square_H\pi(B) \subset \pi(A) \otimes \pi(B) \subset M(S_A) \otimes M(S_B) \subset M(S_A \otimes S_B)$$

Claim: $\pi(A)\square_H\pi(B) \subset M(S_A\square_H S_B)$. Let $\sum x_i \otimes y_i \in \pi(A)\square_H\pi(B)$. It suffices to show $\sum (x_i \otimes y_i)(r_j \otimes s_j) \in S_A\square_H S_B$ and $\sum (r_j \otimes s_j)(x_i \otimes y_i) \in S_A\square_H S_B$, for $\sum r_j \otimes s_j \in S_A\square_H S_B$. We have

$$\sum x_{i(0)} \otimes x_{i(1)} \otimes y_i = \sum x_i \otimes y_{i(1)} \otimes y_{i(0)}$$

and

$$\sum r_{j(0)} \otimes r_{j(1)} \otimes s_j = \sum r_j \otimes s_{j(1)} \otimes s_{j(0)}$$

Hence

$$\begin{aligned} \sum (x_i r_j)_{(0)} \otimes (x_i r_j)_{(1)} \otimes y_i s_j &= \sum x_{i(0)} r_{j(0)} \otimes x_{i(1)} r_{j(1)} \otimes y_i s_j \\ &= \sum x_i r_j \otimes y_{i(1)} s_{j(1)} \otimes s_{j(0)} y_{i(0)} \\ &= \sum x_i r_j \otimes (y_i s_j)_{(1)} \otimes (y_i s_j)_{(0)} \end{aligned}$$

Similarly we can show $\sum (r_j \otimes s_j)(x_i \otimes y_i) \in S_A\square_H S_B$. \square

Proposition 5.4.2.

$$\tilde{\pi} : BRM(k, H) \rightarrow Gal(k, H), \quad \tilde{\pi}([A]) = [\pi(A)]$$

is a well defined group homomorphism.

Proof. If A is a k -flat H -module Taylor-Azumaya algebra, $\pi(A)$ is an H -Galois object (Lemma 5.3.10). Let $E_k(\underline{M})$ be an elementary H -module Taylor-Azumaya algebra. Due to Lemma 5.3.12, the H -action on $E_k(\underline{M})$ is strongly inner. Hence $\pi(E_k(\underline{M})) \cong H$, by Lemma 5.3.13. In other words, $\tilde{\pi}(1) = \tilde{\pi}([E_k(\underline{M})]) = [\pi(E_k(\underline{M}))] = [H] = 1$. If we show that $\tilde{\pi}$ is multiplicative, $\tilde{\pi}$ is well defined. Indeed, suppose $[A] = [B]$ in $BRM(k, H)$, there exists a dual pair of H -modules \underline{M} such that $A \otimes B^{op} \cong E_k(\underline{M})$. Then

$$\begin{aligned} \tilde{\pi}([A])\tilde{\pi}([B])^{-1} &= \tilde{\pi}([A])\tilde{\pi}([B]^{-1}) = \tilde{\pi}([A][B]^{-1}) \\ &= \tilde{\pi}([A][B^{op}]) = \tilde{\pi}([A \otimes B^{op}]) \\ &= \tilde{\pi}([E_k(\underline{M})]) = \tilde{\pi}(1) = 1 \end{aligned}$$

or $[A] = [B]$ implies $\tilde{\pi}([A]) = \tilde{\pi}([B])$. Thus it suffices to show that $\tilde{\pi}$ is multiplicative. Let $[A], [B] \in BRM(k, H)$. We show that $\pi(A \otimes B) \cong \pi(A) \square_H \pi(B)$ as H -Galois objects, then

$$\begin{aligned} \tilde{\pi}([A][B]) &= \tilde{\pi}([A \otimes B]) = [\pi(A \otimes B)] \\ &= [\pi(A) \square_H \pi(B)] = [\pi(A)][\pi(B)] = \tilde{\pi}([A])\tilde{\pi}([B]) \end{aligned}$$

i.e. $\tilde{\pi}$ is multiplicative.

Consider the natural comodule algebra isomorphism $\eta : S_A \square_H S_B \rightarrow S_{A \otimes B}$. η extends to an isomorphism

$$\eta : M(S_A \square_H S_B) \rightarrow M(S_{A \otimes B})$$

Now $\pi(A) \square_H \pi(B)$ is a subalgebra of $M(S_A \square_H S_B)$. By definition of $\pi(A)$ and $\pi(B)$, $\pi(A) \square_H \pi(B)$ commutes with $A \square_H B$. Hence, $\eta(\pi(A) \square_H \pi(B))$ commutes with $A \otimes B$ in $M(S_{A \otimes B})$, or $\eta(\pi(A) \square_H \pi(B)) \subset \pi(A \otimes B)$. In other words, η restricts to a morphism

$$\eta' : \pi(A) \square_H \pi(B) \rightarrow \pi(A \otimes B)$$

Since η' is an H -comodule algebra morphism between H -Galois objects, η' is an isomorphism. This concludes the proof. \square

Theorem 5.4.3. *Let k be a commutative ring and H a cocommutative k -projective Hopf algebra. We have an exact sequence*

$$1 \longrightarrow BR(k) \longrightarrow BRM(k, H) \xrightarrow{\tilde{\pi}} Gal(k, H)$$

Proof. Let $\iota : BR(k) \rightarrow BRM(k, H)$ be the canonical embedding, equipping a Taylor-Azumaya algebra with the trivial H -action. ι is split by $q : BRM(k, H) \rightarrow BR(k)$, which is defined by forgetting the H -module structure. Hence it suffices to show that $Ker \tilde{\pi} = Im \iota \cong BR(k)$. The restriction of q to $Ker \tilde{\pi}$ gives a map

$$\xi : Ker \tilde{\pi} \longrightarrow BR(k)$$

We still have $\xi \circ \iota = 1$ on $BR(k)$. Thus ξ is already surjective.

To show that ξ is injective as well, take $[A] \in Ker \xi$, i.e. A is an H -Taylor-Azumaya algebra such that as a Taylor-Azumaya algebra A is an elementary algebra, say $A \cong E_k(\underline{M})$, for some dual pair of modules $\underline{M} = (M, M', \mu)$. Since $[A] \in Ker \xi \subset Ker \tilde{\pi}$, we have $\tilde{\pi}([A]) = [\pi(A)] = [H]$ implying $\pi(A) \cong H$. By Lemma 5.3.13, the H -action on A is strongly inner. Due to Lemma 5.3.12, there exists an H -module structure on \underline{M} such that the H -action on $E_k(\underline{M})$ is hereby induced. In other words, $A \cong E_k(\underline{M})$ is an elementary H -module algebra. Hence $[A] = [E_k(\underline{M})] = 1$ in $BRM(k, H)$. Thus ξ is injective too. \square

5.5 Surjectivity of $\tilde{\pi}$

We investigate if or when $\tilde{\pi}$ is surjective. In other words, given an H -Galois object B , can we construct an H -module Taylor-Azumaya algebra, say A , such that $\pi(A) \cong B$? If we look at the case where H is faithfully projective, one can choose $B\#H^*$ as a candidate for a preimage of B . This works because H is finitely generated projective, thus its dual H^* is a Hopf algebra. For more details, we refer to [5].

Moreover, in the finite situation, H^* is a Hopf module and H^* contains an integral. If in addition the base ring has a trivial Picard group, the integral space of H is free of rank one.

However, if H is not finitely generated, the dual H^* is not necessarily a Hopf algebra. We wish to find another candidate for the preimage of a Galois object. Our approach is similar to the approach in [16] and relies on the theory of multiplier Hopf algebras, or to be more specific on the dual multiplier Hopf algebra \hat{H} . As we have discussed in Section 5.2, this construction requires the existence of a faithful surjective integral. Hence, for this section, we will assume that H contains a faithful surjective integral φ . The integral on \hat{H} is again denoted by $\hat{\varphi}$.

Let B be a (right) H -Galois object. Recall from Section 1.4 (take $\mathcal{C} = {}_k\mathcal{M}$) the canonical morphism can_+ and the morphism $\gamma : H \rightarrow B \otimes B$. For sake of simplicity, let us now denote

$$(can_+)^{-1}(1 \otimes h) = h^{(1)} \otimes h^{(2)}$$

for $h \in H$. The *Miyashita-Ulbrich action* of H on B is defined by

$$b \leftarrow h = \sum h^{(1)} b h^{(2)}$$

for $b \in B$ and $h \in H$. Under this (right) H -action, B becomes a right H -module algebra and a right-right Yetter-Drinfel'd module. Using the antipode, we can define a left H -action.

$$h \rightarrow b = b \leftarrow S^{-1}(h)$$

With this left H -action, B is a left-right Yetter-Drinfel'd module. As H is cocommutative, B even becomes a left-right Yetter-Drinfel'd module algebra. Moreover, B is quantum commutative in the sense that

$$\sum b_{(0)}(a \leftarrow b_{(1)}) = \sum b_{(0)} b_{(1)}^{(1)} a b_{(1)}^{(2)} = ab$$

since $\sum b_{(0)} b_{(1)}^{(1)} \otimes b_{(1)}^{(2)} = 1 \otimes b$. Furthermore

$$\begin{aligned} \sum (a \leftarrow S^{-1}(b_{(1)})) b_{(0)} &= \sum b_{(0)(0)} ((a \leftarrow S^{-1}(b_{(1)})) \leftarrow b_{(0)(1)}) \\ &= \sum b_{(0)} (a \leftarrow (S^{-1}(b_{(1)(2)}) b_{(1)(1)})) \\ &= ba \end{aligned}$$

Hence

$$\sum (b_{(1)} \rightharpoonup a) b_{(0)} = ba \quad (5.5.1)$$

If B is an H -Galois object, then B is also an \hat{H} -module algebra, with (natural) \hat{H} -action coming from its H -comodule (algebra) structure:

$$\hat{h} \cdot b = \sum \hat{h}(b_{(1)}) b_{(0)} = \sum \langle \hat{h}, b_{(1)} \rangle b_{(0)}$$

for $\hat{h} \in \hat{H}$ and $b \in B$. We can recover the original H -coaction via

$$\rho(b) = \sum v \cdot b \otimes u$$

for $b \in B$, with

$$u \otimes v = \sum \hat{\varphi}(-\varphi_2) \otimes \hat{S}^{-1}(\varphi_1) \in M(H \otimes \hat{H})$$

as in Proposition 5.2.7. If this element occurs multiple times, we will use similar notation like $u' \otimes v'$, $U \otimes V$, etc. The quantum commutativity (5.5.1) then has the following form

$$\sum (u \rightharpoonup a)(v \cdot b) = ba \quad (5.5.2)$$

for $a, b \in B$.

Proposition 5.5.1. *The group homomorphism $\tilde{\pi} : BRM(k, H) \rightarrow Gal(k, H)$ is surjective.*

Proof. Let B be an H -Galois object. We claim that $B \# \hat{H}$ is a k -flat H -Taylor-Azumaya algebra such that $\pi(B \# \hat{H}) \cong B$, or $\tilde{\pi}([B \# \hat{H}]) = [\pi(B \# \hat{H})] = [B]$. By [82, Theorem 4.3], there exists a strict Morita context

$$(B \# \hat{H}, k, B, B, [-, -], (-, -))$$

The bimodule isomorphisms are given by

$$[-, -] : B \otimes B \rightarrow B \# \hat{H}, [b, b'] = \sum b b'_{(0)} \otimes \varphi(b'_{(1)} -)$$

and

$$(-, -) : B \otimes_{B \# \hat{H}} B \rightarrow k, (b, b') = \sum b_{(0)} b'_{(0)} \varphi(b_{(1)} b'_{(1)})$$

The left $B \# \hat{H}$ -action on B is given by

$$(b' \# \hat{h}) \cdot b = b'(\hat{h} \cdot b)$$

and the right $B \# \hat{H}$ -action by

$$b \cdot (b' \# \hat{h}) = \hat{S}^{-1}(\hat{h}) \cdot (bb')$$

for $b, b' \in B$ and $\hat{h} \in \hat{H}$. The Morita context is strict because of the fact that the canonical map β is an isomorphism.

In view of this Morita context, $B\#\hat{H}$ is isomorphic to the elementary algebra $E_k(\underline{B})$ where $\underline{B} = (B, B, (-, -))$, the isomorphism is given by $[-, -]$. Hence $B\#\hat{H}$ is a Taylor-Azumaya algebra. B is flat, since B is an H -Galois object. As a result, $B\#\hat{H} \cong B \otimes B$ is also flat as a k -module. Thus $B\#\hat{H} \in BR(k)$. Finally, $B\#\hat{H}$ is also an H -module algebra. The H -action comes from the natural H -action on \hat{H}

$$h \triangleright \hat{h} = \hat{h}(-h) = \sum \hat{h}_1 \langle \hat{h}_2, h \rangle$$

for $h \in H$ and $\hat{h} \in \hat{H}$. Thus $[B\#\hat{H}] \in BRM(k, H)$.
Define $\theta : B \rightarrow \pi(B\#\hat{H})$

$$\theta(b) = \sum ((u \rightarrow b_{(0)})\#v)\#b_{(1)}$$

The H -comodule structure on $M(B\#\hat{H})\#H$ is given by

$$\bar{\rho} : M(B\#\hat{H})\#H \rightarrow M(B\#\hat{H})\#H \otimes H, \quad \bar{\rho}(x\#h) = \sum x\#h_1 \otimes h_2$$

and θ is obviously an H -comodule morphism. We verify that $\theta(B) \subset \pi(B\#\hat{H})$. Let $b \in B$ and $a\#\hat{h} \in B\#\hat{H}$. By definition, $\theta(b) \in \pi(B\#\hat{H})$ if $\theta(b)((a\#\hat{h})\#1) = ((a\#\hat{h})\#1)\theta(b)$.

$$\begin{aligned} & ((a\#\hat{h})\#1)\theta(b) \\ &= \sum ((a\#\hat{h})\#1)((u \rightarrow b_{(0)})\#v)\#b_{(1)} \\ &= \sum ((a\#\hat{h})((u \rightarrow b_{(0)})\#v))\#b_{(1)} \\ &= \sum (a(\hat{h}_1 \cdot (u \rightarrow b_{(0)}))\#\hat{h}_2v)\#b_{(1)} \\ &= \sum (a(u \rightarrow b_{(0)})_{(0)}\langle \hat{h}_1, (u \rightarrow b_{(0)})_{(1)} \rangle\#\hat{h}_2v)\#b_{(1)} \\ &= \sum (a(u'' \rightarrow b_{(0)})\langle \hat{h}_1, u'''b_{(1)}S^{-1}(u') \rangle\#\hat{h}_2v'v''v''')\#b_{(2)} \\ &= \sum (a(u'' \rightarrow b_{(0)})\langle \hat{h}_1, u''' \rangle\langle \hat{h}_2, b_{(1)} \rangle\langle \hat{h}_3, S^{-1}(u') \rangle\#\hat{h}_4v'v''v''')\#b_{(2)} \\ &= \sum (a(u'' \rightarrow b_{(0)})\langle \hat{h}_1, u''' \rangle\langle \hat{h}_2, b_{(1)} \rangle\langle \hat{S}^{-1}(\hat{h}_3), u' \rangle\#\hat{h}_4v'v''v''')\#b_{(2)} \\ &= \sum (a(u'' \rightarrow b_{(0)})\langle \hat{h}_2, b_{(1)} \rangle\#\hat{h}_4\hat{S}^{-1}(\hat{h}_3)v''\hat{h}_1)\#b_{(2)} \\ &= \sum (a(u \rightarrow b_{(0)})\#v(b_{(1)} \triangleright \hat{h}))\#b_{(2)} \end{aligned}$$

on the other hand

$$\begin{aligned}
& \theta(b)((a\#\hat{h})\#1) \\
&= \sum (((u \rightarrow b_{(0)})\#v)\#b_{(1)})((a\#\hat{h})\#1) \\
&= \sum (((u \rightarrow b_{(0)})\#v)(b_{(1)} \cdot (a\#\hat{h}))\#b_{(2)}) \\
&= \sum (((u \rightarrow b_{(0)})\#v)(a\#(b_{(1)} \triangleright \hat{h}))\#b_{(2)}) \\
&= \sum ((u'u'' \rightarrow b_{(0)})(v' \cdot a)\#v''(b_{(1)} \triangleright \hat{h}))\#b_{(2)} \\
&= \sum (a(u \rightarrow b_{(0)})\#v(b_{(1)} \triangleright \hat{h}))\#b_{(2)} && \text{by (5.5.2)} \\
&= ((a\#\hat{h})\#1)\theta(b)
\end{aligned}$$

Hence $\theta(B) \subset \pi(B\#\hat{H})$.

We verify that θ is an algebra map as well, let $b, c \in B$, then

$$\begin{aligned}
& \theta(b)\theta(c) \\
&= \sum (((u \rightarrow b_{(0)})\#v)\#b_{(1)})(((U \rightarrow c_{(0)})\#V)\#c_{(1)}) \\
&= \sum (((u \rightarrow b_{(0)})\#v)(b_{(1)} \cdot ((U \rightarrow c_{(0)})\#V))\#b_{(2)}c_{(1)}) \\
&= \sum (((u \rightarrow b_{(0)})\#v)((U \rightarrow c_{(0)})\#(b_{(1)} \triangleright V))\#b_{(2)}c_{(1)}) \\
&= \sum ((u'u'' \rightarrow b_{(0)})(v' \cdot (U \rightarrow c_{(0)}))\#v''(b_{(1)} \triangleright V))\#b_{(2)}c_{(1)} \\
&= \sum ((u'u'' \rightarrow b_{(0)})(U \rightarrow c_{(0)})_{(0)}\langle v', (U \rightarrow c_{(0)})_{(1)}\#v''(b_{(1)} \triangleright V) \rangle\#b_{(2)}c_{(1)}) \\
&= \sum ((u'u'' \rightarrow b_{(0)})(U'' \rightarrow c_{(0)})\langle v', U'''c_{(1)}S^{-1}(U') \rangle \\
&\quad \#v''(b_{(1)} \triangleright (V'V''V''')))\#b_{(2)}c_{(2)}) \\
&= \sum ((U'''c_{(1)}S^{-1}(U')u \rightarrow b_{(0)})(U'' \rightarrow c_{(0)})\#v(b_{(1)} \triangleright (V'V''V''')))\#b_{(2)}c_{(2)}) \\
&= \sum (U'' \rightarrow ((c_{(1)}S^{-1}(U')u \rightarrow b_{(0)})c_{(0)})\#v(b_{(1)} \triangleright (V'V''))\#b_{(2)}c_{(2)}) \\
&= \sum (U'' \rightarrow (c_{(0)}(S^{-1}(U')u \rightarrow b_{(0)}))\#v(b_{(1)} \triangleright (V'V''))\#b_{(2)}c_{(1)}) && \text{by (5.5.1)} \\
&= \sum ((U''' \rightarrow c_{(0)})(U''S^{-1}(U')u \rightarrow b_{(0)})\#v(b_{(1)} \triangleright (V'V''V''')))\#b_{(2)}c_{(1)}) \\
&= \sum ((U \rightarrow c_{(0)})(u \rightarrow b_{(0)})\#v(b_{(1)} \triangleright V))\#b_{(2)}c_{(1)}) \\
&= \sum ((U'U'' \rightarrow c_{(0)})(u \rightarrow b_{(0)})\#vV'\langle V'', b_{(1)} \rangle)\#b_{(2)}c_{(1)}) \\
&= \sum ((Ub_{(1)} \rightarrow c_{(0)})(u \rightarrow b_{(0)})\#vV)\#b_{(2)}c_{(1)}) \\
&= \sum (u \rightarrow ((b_{(1)} \rightarrow c_{(0)})b_{(0)})\#v)\#b_{(2)}c_{(1)}) \\
&= \sum (u \rightarrow (b_{(0)}c_{(0)})\#v)\#b_{(1)}c_{(1)}) && \text{by (5.5.1)}
\end{aligned}$$

$$= \theta(bc)$$

Finally, as an H -comodule algebra map between H -Galois objects B and $\pi(B\#\hat{H})$, θ is an isomorphism, establishing that $\tilde{\pi}$ is surjective. \square

Combining the above proposition with Theorem 5.4.3, we obtain the following result.

Theorem 5.5.2. *Let k be a commutative ring and H a cocommutative k -projective Hopf algebra with a faithful and surjective integral. We have a split exact sequence*

$$1 \longrightarrow BR(k) \longrightarrow BRM(k, H) \xrightarrow{\tilde{\pi}} Gal(k, H) \longrightarrow 1$$

Remark 5.5.3. In the faithfully projective case, the assumption of a faithful and surjective integral is not required, however, if such an integral exists, the role of the element $u \otimes v$ is equivalent to the role of the finite dual base of H .

5.6 Examples

We conclude this chapter with the computation of some examples.

- (1) If k is a field, then for any Hopf algebra with an integral, the space of integrals is one-dimensional. Moreover, we know $BR(k) = Br(k)$ and $BRM(k, H) = BM(k, H)$, hence for a Hopf algebra with integral over a field k , we obtain a split exact sequence

$$1 \longrightarrow Br(k) \longrightarrow BM(k, H) \xrightarrow{\tilde{\pi}} Gal(k, H) \longrightarrow 1$$

- (2) Let k be any commutative ring and G an infinite group. The map $p_e : kG \rightarrow k$ (see Example 5.2.6) can be seen as an integral on kG . Moreover, it is faithful and surjective. Thus we have

$$1 \longrightarrow BR(k) \longrightarrow BRM(k, kG) \xrightarrow{\tilde{\pi}} Gal(k, G) \longrightarrow 1$$

A kG -comodule algebra B is nothing but a G -graded algebra B . $B^{co(kG)} = k$ implies $B_e = k$ while the canonical map being an isomorphism implies the G -grading to be strong. In particular, one can show $B_\sigma \otimes B_{\sigma^{-1}} \cong B_e = k$, thus B_σ is an invertible k -module. Hence B_σ and $B = \bigoplus_\sigma B_\sigma$ are flat. Hence Lemma 5.3.9 and the flatness requirement are redundant. In other words, Lemma 5.3.8 shows that for any kG -module Taylor-Azumaya algebra A , $\pi(A)$ is a Galois object. Therefore we even obtain

$$1 \longrightarrow Br'(k) \longrightarrow BM'(k, kG) \xrightarrow{\tilde{\pi}} Gal(k, G) \longrightarrow 1$$

This is the main result of [16].

- (3) The group Hopf algebra is the most common example of an infinite cocommutative Hopf algebra with integral. However, we can take the tensor product of kG with any finitely generated cocommutative Hopf algebra H with (faithful and surjective) integral to get a new infinite cocommutative Hopf algebra with (faithful and surjective) integral.

To find such an H , one can for example look at so called *Hopf orders*. Here, let k be a domain and K its field of fractions. A k -Hopf algebra is called a *Hopf order* in KG if H satisfies $H \otimes_k K \cong KG$ as K -Hopf algebras. In [47] it is described how a class of such orders arises from (so called p -adic order-bounded) group valuations. The obtained Hopf orders are called *Larson orders*. Larson orders in KC_p are known to be Tate-Oort algebras of the form $H_b = k[x]/\langle x^p - bx \rangle$ (see [75]). Moreover, Galois extensions over orders have already been studied by (e.g.) [66, 79].

In particular, consider the following example (cf. [12]). Let $k = \mathbb{Z}[\sqrt{2}]$ and consider the Hopf order

$$H = k\left[\frac{y}{\sqrt{2}}\right]/\left\langle \frac{(y+1)^2 - 1}{2} \right\rangle = k[x]/\langle x^2 + \sqrt{2}x \rangle$$

with

$$\Delta(x) = \sqrt{2}x \otimes x + x \otimes 1 + 1 \otimes x ; \quad \epsilon(x) = 0 ; \quad S(x) = x$$

Then $Gal(k, H) = \mathbb{Z}_2$ [12, Example 13.12.18] as well as $Hopf(kG, H) = \mathbb{Z}_2$. Hence, for $\overline{H} = kG \otimes H$, we have

$$\begin{aligned} BRM(k, \overline{H}) &= BR(k) \oplus Gal(k, \overline{H}) \\ &= BR(k) \oplus Gal(k, kG) \oplus Gal(k, H) \oplus Hopf(kG, H) \\ &= BR(k) \oplus Gal(k, kG) \oplus \mathbb{Z}_2 \oplus \mathbb{Z}_2 \end{aligned}$$

Finally, if $Pic(k) = 1$, $Gal(k, kG)$ can be replaced by $H^2(kG, U(k))$.

Appendix A

Structure theorems for bicomodule algebras

The need for a structure theorem for bicomodule algebras (over a classical Hopf algebra H) has been established in Chapter 3. Using this structure theorem we were able to give a description for the image of this morphism $\xi : \text{BiGal}({}_H^H\mathcal{YD}; B) \rightarrow \text{BiGal}(B \rtimes H)$.

It appears natural to try to see whether the structure theorem for bicomodule algebras remains valid over more general Hopf algebra-type objects. In Chapter 2 we have already proven the existence of a structure theorem for braided bicomodule algebras over a braided Hopf algebra. It is the aim of this chapter to show that we can also replace the Hopf algebra H by a quasi-Hopf algebra or a weak Hopf algebra.

In both cases, the result is that if B is an H -bicomodule algebra (in an appropriate sense in each case) such that there exists a morphism of H -bicomodule algebras $v : H \rightarrow B$, then we can define an object $B^{co(H)}$ which is a left-left Yetter-Drinfeld module over H , having extra properties that allow to make a smash product $B^{co(H)} \# H$ which is an H -bicomodule algebra, isomorphic to B . As in Chapter 2, the proof relies on an analogue of Schauenburg's theorem that the categories of two-sided two-sided Hopf modules and Yetter-Drinfeld modules are equivalent, cf. [67].

This chapter is organized as follows: it contains two sections, each one with its own preliminaries, each one containing the proof of the structure theorem for both Hopf algebra-type objects mentioned above.

We work over a field k .

A.1 Quasi-Hopf bicomodule algebras

Following [36], a *quasi-bialgebra* is a fourtuple $(H, \Delta, \varepsilon, \Phi)$, where H is an associative algebra with unit 1, Φ is an invertible element in $H \otimes H \otimes H$, and $\Delta : H \rightarrow H \otimes H$ and $\varepsilon : H \rightarrow k$ are algebra homomorphisms satisfying the following identities

$$(id \otimes \Delta)(\Delta(h)) = \Phi(\Delta \otimes id)(\Delta(h))\Phi^{-1}, \quad (\text{A.1.1})$$

$$(id \otimes \varepsilon)(\Delta(h)) = h \otimes 1, \quad (\varepsilon \otimes id)(\Delta(h)) = 1 \otimes h, \quad (\text{A.1.2})$$

$$(1 \otimes \Phi)(id \otimes \Delta \otimes id)(\Phi)(\Phi \otimes 1) = (id \otimes id \otimes \Delta)(\Phi)(\Delta \otimes id \otimes id)(\Phi), \quad (\text{A.1.3})$$

$$(\varepsilon \otimes id \otimes id)(\Phi) = (id \otimes \varepsilon \otimes id)(\Phi) = (id \otimes id \otimes \varepsilon)(\Phi) = 1 \otimes 1 \otimes 1. \quad (\text{A.1.4})$$

for all $h \in H$. The map Δ is called the *comultiplication*, ε the *counit* and Φ the *associator*. We denote the tensor components of Φ by capital letters and those of Φ^{-1} by small letters:

$$\Phi = X^1 \otimes X^2 \otimes X^3 = T^1 \otimes T^2 \otimes T^3 = Y^1 \otimes Y^2 \otimes Y^3 = \dots$$

$$\Phi^{-1} = x^1 \otimes x^2 \otimes x^3 = t^1 \otimes t^2 \otimes t^3 = y^1 \otimes y^2 \otimes y^3 = \dots$$

A quasi-bialgebra H is called a *quasi-Hopf algebra* if there exists an anti-algebra morphism $S : H \rightarrow H$ and elements $\alpha, \beta \in H$ such that, for all $h \in H$, we have:

$$S(h_1)\alpha h_2 = \varepsilon(h)\alpha \quad \text{and} \quad h_1\beta S(h_2) = \varepsilon(h)\beta, \quad (\text{A.1.5})$$

$$X^1\beta S(X^2)\alpha X^3 = 1 \quad \text{and} \quad S(x^1)\alpha x^2\beta S(x^3) = 1. \quad (\text{A.1.6})$$

These axioms imply that $\varepsilon(\alpha)\varepsilon(\beta) = 1$, so, by rescaling α and β , we may assume without loss of generality that $\varepsilon(\alpha) = \varepsilon(\beta) = 1$ and $\varepsilon \circ S = \varepsilon$.

Suppose that $(H, \Delta, \varepsilon, \Phi)$ is a quasi-bialgebra. If U, V, W are left H -modules, define $a_{U,V,W} : (U \otimes V) \otimes W \rightarrow U \otimes (V \otimes W)$ by $a_{U,V,W}((u \otimes v) \otimes w) = \Phi \cdot (u \otimes (v \otimes w))$. The category ${}_H\mathcal{M}$ of left H -modules becomes a monoidal category, where $U \otimes V$ is a left H -module with diagonal action $h \cdot (u \otimes v) = h_1 \cdot u \otimes h_2 \cdot v$, for $u \in U, v \in V$. Similarly, the category of right H -modules \mathcal{M}_H is a monoidal with $\mathbf{a}_{U,V,W} : (U \otimes V) \otimes W \rightarrow U \otimes (V \otimes W)$ defined by $\mathbf{a}_{U,V,W}((u \otimes v) \otimes w) = (u \otimes (v \otimes w)) \cdot \Phi^{-1}$.

Let H be a quasi-bialgebra. A k -vector space A is called a *left H -module algebra* if it is an algebra in the monoidal category ${}_H\mathcal{M}$, that is A has a multiplication and a usual unit 1_A satisfying the following conditions:

$$(aa')a'' = (X^1 \cdot a)[(X^2 \cdot a')(X^3 \cdot a'')], \quad (\text{A.1.7})$$

$$h \cdot (aa') = (h_1 \cdot a)(h_2 \cdot a'), \quad h \cdot 1_A = \varepsilon(h)1_A, \quad (\text{A.1.8})$$

for all $a, a', a'' \in A$ and $h \in H$, where $h \otimes a \rightarrow h \cdot a$ is the left H -module structure of A . Following [11] we define the *smash product* $A\#H$ as follows: as vector space $A\#H$ is $A \otimes H$ (elements $a \otimes h$ will be written $a\#h$) with multiplication given by $(a\#h)(a'\#h') = (x^1 \cdot a)(x^2 h_1 \cdot a')\#x^3 h_2 h'$. The smash product $A\#H$ is an associative algebra with unit $1_A\#1_H$.

Recall from [42] the notion of a (bi)comodule algebra over a quasi-bialgebra.

Definition A.1.1. Let H be a quasi-bialgebra. A unital associative algebra B is called a *right H -comodule algebra* if there exist an algebra morphism $\rho : B \rightarrow B \otimes H$ and an invertible element $\Phi_\rho \in B \otimes H \otimes H$ such that:

$$\Phi_\rho(\rho \otimes id)(\rho(b)) = (id \otimes \Delta)(\rho(b))\Phi_\rho, \quad \forall b \in B, \quad (\text{A.1.9})$$

$$\begin{aligned} (1_B \otimes \Phi)(id \otimes \Delta \otimes id)(\Phi_\rho)(\Phi_\rho \otimes 1_H) \\ = (id \otimes id \otimes \Delta)(\Phi_\rho)(\rho \otimes id \otimes id)(\Phi_\rho), \end{aligned} \quad (\text{A.1.10})$$

$$(id \otimes \varepsilon) \circ \rho = id, \quad (\text{A.1.11})$$

$$(id \otimes \varepsilon \otimes id)(\Phi_\rho) = (id \otimes id \otimes \varepsilon)(\Phi_\rho) = 1_B \otimes 1_H. \quad (\text{A.1.12})$$

Similarly, a unital associative algebra B is called a *left H -comodule algebra* if there exist an algebra morphism $\lambda : B \rightarrow H \otimes B$ and an invertible element $\Phi_\lambda \in H \otimes H \otimes B$ such that:

$$(id \otimes \lambda)(\lambda(b))\Phi_\lambda = \Phi_\lambda(\Delta \otimes id)(\lambda(b)), \quad \forall b \in B, \quad (\text{A.1.13})$$

$$\begin{aligned} (1_H \otimes \Phi_\lambda)(id \otimes \Delta \otimes id)(\Phi_\lambda)(\Phi \otimes 1_B) \\ = (id \otimes id \otimes \lambda)(\Phi_\lambda)(\Delta \otimes id \otimes id)(\Phi_\lambda), \end{aligned} \quad (\text{A.1.14})$$

$$(\varepsilon \otimes id) \circ \lambda = id, \quad (\text{A.1.15})$$

$$(id \otimes \varepsilon \otimes id)(\Phi_\lambda) = (\varepsilon \otimes id \otimes id)(\Phi_\lambda) = 1_H \otimes 1_B. \quad (\text{A.1.16})$$

Finally, by an *H -bicomodule algebra* B we mean a quintuple $(\lambda, \rho, \Phi_\lambda, \Phi_\rho, \Phi_{\lambda,\rho})$, where λ and ρ are left and right H -coactions on B , respectively, and where $\Phi_\lambda \in H \otimes H \otimes B$, $\Phi_\rho \in B \otimes H \otimes H$ and $\Phi_{\lambda,\rho} \in H \otimes B \otimes H$ are invertible elements, such that $(B, \lambda, \Phi_\lambda)$ is a left H -comodule algebra, (B, ρ, Φ_ρ) is a right H -comodule algebra and the following compatibility relations hold:

$$\Phi_{\lambda,\rho}(\lambda \otimes id)(\rho(u)) = (id \otimes \rho)(\lambda(u))\Phi_{\lambda,\rho}, \quad \forall u \in B, \quad (\text{A.1.17})$$

$$\begin{aligned} (1_H \otimes \Phi_{\lambda,\rho})(id \otimes \lambda \otimes id)(\Phi_{\lambda,\rho})(\Phi_\lambda \otimes 1_H) \\ = (id \otimes id \otimes \rho)(\Phi_\lambda)(\Delta \otimes id \otimes id)(\Phi_{\lambda,\rho}), \end{aligned} \quad (\text{A.1.18})$$

$$\begin{aligned} (1_H \otimes \Phi_\rho)(id \otimes \rho \otimes id)(\Phi_{\lambda,\rho})(\Phi_{\lambda,\rho} \otimes 1_H) \\ = (id \otimes id \otimes \Delta)(\Phi_{\lambda,\rho})(\lambda \otimes id \otimes id)(\Phi_\rho). \end{aligned} \quad (\text{A.1.19})$$

As pointed out in [42], if B is a bicomodule algebra then, in addition, we have:

$$\begin{aligned} (id_H \otimes id_B \otimes \varepsilon)(\Phi_{\lambda,\rho}) &= 1_H \otimes 1_B \\ (\varepsilon \otimes id_B \otimes id_H)(\Phi_{\lambda,\rho}) &= 1_B \otimes 1_H. \end{aligned} \quad (\text{A.1.20})$$

An example of a bicomodule algebra is $B = H$, $\lambda = \rho = \Delta$ and $\Phi_\lambda = \Phi_\rho = \Phi_{\lambda,\rho} = \Phi$. If $(B, \lambda, \rho, \Phi_\lambda, \Phi_\rho, \Phi_{\lambda,\rho})$ and $(B', \lambda', \rho', \Phi_{\lambda'}, \Phi_{\rho'}, \Phi_{\lambda',\rho'})$ are H -bicomodule algebras, a morphism of H -bicomodule algebras $f : B \rightarrow B'$ is an algebra map such that $\rho' \circ f =$

$(f \otimes id_H) \circ \rho, \lambda' \circ f = (id_H \otimes f) \circ \lambda, \Phi_{\rho'} = (f \otimes id_H \otimes id_H)(\Phi_\rho), \Phi_{\lambda'} = (id_H \otimes id_H \otimes f)(\Phi_\lambda)$ and $\Phi_{\lambda', \rho'} = (id_H \otimes f \otimes id_H)(\Phi_{\lambda, \rho})$.

Let us denote by ${}_H\mathcal{M}_H$ the category of H -bimodules; it is also a monoidal category, the associativity constraints being given by $\mathbf{a}'_{U,V,W} : (U \otimes V) \otimes W \rightarrow U \otimes (V \otimes W)$, $\mathbf{a}'_{U,V,W}((u \otimes v) \otimes w) = \Phi \cdot (u \otimes (v \otimes w)) \cdot \Phi^{-1}$, for $U, V, W \in {}_H\mathcal{M}_H$ and $u \in U, v \in V, w \in W$. Therefore, we can define coalgebras in the category of H -bimodules; in particular, the axioms for H ensure that H is a (coassociative) coalgebra in ${}_H\mathcal{M}_H$. We recall from [56] the definition of left-left Yetter-Drinfeld modules over a quasi-bialgebra H .

Definition A.1.2. A k -linear space M is called a *left-left Yetter-Drinfeld module over H* if M is a left H -module and there is a left coaction denoted by $\lambda_M : M \rightarrow H \otimes M$, $\lambda_M(m) = m_{(-1)} \otimes m_{(0)}$ such that:

$$\begin{aligned} X^1 m_{(-1)} \otimes (X^2 \cdot m_{(0)})_{(-1)} X^3 \otimes (X^2 \cdot m_{(0)})_{(0)} \\ = X^1((Y^1 \cdot m)_{(-1)})_1 Y^2 \otimes X^2((Y^1 \cdot m)_{(-1)})_2 Y^3 \otimes X^3 \cdot (Y^1 \cdot m)_{(0)}, \end{aligned} \quad (\text{A.1.21})$$

$$\varepsilon(m_{(-1)})m_{(0)} = m, \quad (\text{A.1.22})$$

$$h_1 m_{(-1)} \otimes h_2 \cdot m_{(0)} = (h_1 \cdot m)_{(-1)} h_2 \otimes (h_1 \cdot m)_{(0)}, \quad (\text{A.1.23})$$

for all $m \in M$ and $h \in H$. The category ${}^H_H\mathcal{YD}$ consists of such objects, the morphisms in the category being the H -linear maps intertwining the H -coactions.

The category ${}^H_H\mathcal{YD}$ is (pre) braided monoidal; explicitly, if (M, λ_M) and (N, λ_N) are objects in ${}^H_H\mathcal{YD}$, then $(M \otimes N)$ is also object in ${}^H_H\mathcal{YD}$, where $M \otimes N$ is a left H -module with action $h \cdot (m \otimes n) = h_1 \cdot m \otimes h_2 \cdot n$, and the coaction $\lambda_{M \otimes N}$ is given by

$$\begin{aligned} \lambda_{M \otimes N}(m \otimes n) = X^1(x^1 Y^1 \cdot m)_{(-1)} x^2 (Y^2 \cdot n)_{(-1)} Y^3 \otimes X^2 \cdot (x^1 Y^1 \cdot m)_{(0)} \\ \otimes X^3 x^3 \cdot (Y^2 \cdot n)_{(0)}. \end{aligned}$$

The associativity constraints are the same as in ${}_H\mathcal{M}$, and the (pre) braiding is given by

$$\phi_{M,N} : M \otimes N \rightarrow N \otimes M, \quad \phi_{M,N}(m \otimes n) = m_{(-1)} \cdot n \otimes m_{(0)}.$$

Since ${}^H_H\mathcal{YD}$ is a monoidal category, we can speak about algebras in ${}^H_H\mathcal{YD}$. Namely, if A is an object in ${}^H_H\mathcal{YD}$, then A is an algebra in ${}^H_H\mathcal{YD}$ if and only if A is a left H -module algebra and A is a left quasi-comodule algebra, that is its unit and multiplication intertwine the H -coaction λ_A , namely (for all $a, a' \in A$):

$$\lambda_A(1_A) = 1_H \otimes 1_A, \quad (\text{A.1.24})$$

$$\begin{aligned} \lambda_A(aa') = X^1(x^1 Y^1 \cdot a)_{(-1)} x^2 (Y^2 \cdot a')_{(-1)} Y^3 \\ \otimes [X^2 \cdot (x^1 Y^1 \cdot a)_{(0)}][X^3 x^3 \cdot (Y^2 \cdot a')_{(0)}]. \end{aligned} \quad (\text{A.1.25})$$

We recall the following result from [1]:

Proposition A.1.3. *Let H be a quasi-bialgebra and A an algebra in ${}^H_H\mathcal{YD}$. Then $(A\#H, \lambda, \rho, \Phi_\lambda, \Phi_\rho, \Phi_{\lambda, \rho})$ is an H -bicomodule algebra, with structures:*

$$\begin{aligned}\lambda &: A\#H \rightarrow H \otimes (A\#H), \\ \lambda(a\#h) &= T^1(t^1 \cdot a)_{(-1)}t^2h_1 \otimes (T^2 \cdot (t^1 \cdot a)_{(0)})\#T^3t^3h_2, \\ \rho &: A\#H \rightarrow (A\#H) \otimes H, \\ \rho(a\#h) &= (x^1 \cdot a\#x^2h_1) \otimes x^3h_2, \\ \Phi_\lambda &= X^1 \otimes X^2 \otimes (1_A\#X^3) \in H \otimes H \otimes (A\#H), \\ \Phi_\rho &= (1_A\#X^1) \otimes X^2 \otimes X^3 \in (A\#H) \otimes H \otimes H, \\ \Phi_{\lambda, \rho} &= X^1 \otimes (1_A\#X^2) \otimes X^3 \in H \otimes (A\#H) \otimes H.\end{aligned}$$

Moreover, one can easily see that in the hypotheses of Proposition A.1.3, the map $H \rightarrow A\#H, h \mapsto 1_A\#h$, is a morphism of H -bicomodule algebras.

We prove now a partial converse of Proposition A.1.3.

Proposition A.1.4. *Let H be a quasi-bialgebra and A an object in ${}^H_H\mathcal{YD}$. Assume that A is also a left H -module algebra. Assume that the map*

$$\begin{aligned}\lambda &: A\#H \rightarrow H \otimes (A\#H), \\ \lambda(a\#h) &= T^1(t^1 \cdot a)_{(-1)}t^2h_1 \otimes (T^2 \cdot (t^1 \cdot a)_{(0)})\#T^3t^3h_2\end{aligned}$$

is an algebra map. Then A is an algebra in ${}^H_H\mathcal{YD}$.

Proof. The fact that λ is unital implies immediately that λ_A is unital, so the only thing left to prove is the relation (A.1.25) for A . Let $a, a' \in A$. Since λ is multiplicative, we have

$$\lambda((Z^1 \cdot a\#1)(Z^2 \cdot a'\#Z^3)) = \lambda(Z^1 \cdot a\#1)\lambda(Z^2 \cdot a'\#Z^3)$$

We compute the left and right hand sides of this equality:

$$\begin{aligned}& \lambda((Z^1 \cdot a\#1)(Z^2 \cdot a'\#Z^3)) \\ &= \lambda((z^1Z^1 \cdot a)(z^2Z^2 \cdot a'))\#z^3Z^3 \\ &= \lambda(aa'\#1) \\ &= T^1(t^1 \cdot aa')_{(-1)}t^2 \otimes (T^2 \cdot (t^1 \cdot aa')_{(0)})\#T^3t^3,\end{aligned}$$

$$\begin{aligned}& \lambda(Z^1 \cdot a\#1)\lambda(Z^2 \cdot a'\#Z^3) \\ &= [T^1(t^1Z^1 \cdot a)_{(-1)}t^2 \otimes (T^2 \cdot (t^1Z^1 \cdot a)_{(0)})\#T^3t^3] \\ & [Y^1(y^1Z^2 \cdot a')_{(-1)}y^2Z_1^3 \otimes (Y^2 \cdot (y^1Z^2 \cdot a')_{(0)})\#Y^3y^3Z_2^3] \\ &= T^1(t^1Z^1 \cdot a)_{(-1)}t^2Y^1(y^1Z^2 \cdot a')_{(-1)}y^2Z_1^3 \otimes \\ & [x^1T^2 \cdot (t^1Z^1 \cdot a)_{(0)}][x^2T_1^3t_1^3Y^2 \cdot (y^1Z^2 \cdot a')_{(0)}]\#x^3T_2^3t_2^3Y^3y^3Z_2^3.\end{aligned}$$

Now we apply ε on the last position in both terms. We obtain:

$$\begin{aligned}
& (id \otimes \varepsilon)(\lambda((Z^1 \cdot a \# 1)(Z^2 \cdot a' \# Z^3))) \\
&= (aa')_{(-1)} \otimes (aa')_{(0)} = \lambda_A(aa'), \\
& (id \otimes \varepsilon)(\lambda(Z^1 \cdot a \# 1)\lambda(Z^2 \cdot a' \# Z^3)) \\
&= T^1(t^1 Z^1 \cdot a)_{(-1)} t^2(Z^2 \cdot a')_{(-1)} Z^3 \otimes [T^2 \cdot (t^1 Z^1 \cdot a)_{(0)}][T^3 t^3 \cdot (Z^2 \cdot a')_{(0)}].
\end{aligned}$$

The equality of these two terms is exactly the desired relation (A.1.25). \square

Let H be a quasi-bialgebra and M an H -bimodule together with a right and a left H -coaction $\rho : M \rightarrow M \otimes H$ and $\lambda : M \rightarrow H \otimes M$, with notation $\rho(m) = m_{(0)} \otimes m_{(1)}$ and $\lambda(m) = m_{<-1>} \otimes m_{<0>}$. Then (M, λ, ρ) is called a *(two-sided two-cosided) quasi-Hopf H -bimodule* if M is an H -bicomodule in the monoidal category ${}_H\mathcal{M}_H$, that is if the following conditions are satisfied, for all $m \in M$:

$$(id_M \otimes \varepsilon) \circ \rho = id_M, \quad (\text{A.1.26})$$

$$\Phi \cdot (\rho \otimes id_H)(\rho(m)) = (id_M \otimes \Delta)(\rho(m)) \cdot \Phi, \quad (\text{A.1.27})$$

$$(\varepsilon \otimes id_M) \circ \lambda = id_M, \quad (\text{A.1.28})$$

$$(id_H \otimes \lambda)(\lambda(m)) \cdot \Phi = \Phi \cdot (\Delta \otimes id_M)(\lambda(m)), \quad (\text{A.1.29})$$

$$\Phi \cdot (\lambda \otimes id_H)(\rho(m)) = (id_H \otimes \rho)(\lambda(m)) \cdot \Phi. \quad (\text{A.1.30})$$

The category of two-sided two-cosided quasi-Hopf H -bimodules will be denoted by ${}_H^H\mathcal{M}_H^H$ (the morphisms in the category are the H -bimodule maps intertwining the H -coactions), cf. [71].

Let H be a quasi-Hopf algebra and M an object in ${}_H^H\mathcal{M}_H^H$, with notation as above. Then in particular M is also an object in the category ${}_H\mathcal{M}_H^H$ of quasi-Hopf H -bimodules introduced in [41]. So, following [41], we can define the map $E : M \rightarrow M$ by the formula

$$E(m) = q^1 \cdot m_{(0)} \cdot \beta S(q^2 m_{(1)}), \quad \forall m \in M, \quad (\text{A.1.31})$$

where $q_R = q^1 \otimes q^2 = X^1 \otimes S^{-1}(\alpha X^3) X^2$. Also, for $h \in H$ and $m \in M$, define

$$h \triangleright m = E(h \cdot m). \quad (\text{A.1.32})$$

Some properties of E and \triangleright are collected in [41, Proposition 3.4], for instance (for $h, h' \in H$ and $m \in M$): $E^2 = E$; $E(m \cdot h) = E(m)\varepsilon(h)$; $h \triangleright E(m) = E(h \cdot m) \equiv h \triangleright m$; $(hh') \triangleright m = h \triangleright (h' \triangleright m)$; $h \cdot E(m) = (h_1 \triangleright E(m)) \cdot h_2$; $E(m_{(0)}) \cdot m_{(1)} = m$; $E(E(m)_{(0)}) \otimes E(m)_{(1)} = E(m) \otimes 1$. Because of these properties, the following notions of *coinvariants* all coincide:

$$\begin{aligned}
M^{co(H)} &= E(M) = \{n \in M / E(n) = n\} \\
&= \{n \in M / E(n_{(0)}) \otimes n_{(1)} = E(n) \otimes 1\}.
\end{aligned}$$

From the above properties it follows that $(M^{\text{co}(H)}, \triangleright)$ is a left H -module.

In [71], Schauenburg proved a structure theorem for objects in ${}^H_H\mathcal{M}_H^H$, that can be reformulated as follows:

Theorem A.1.5 ([71]). *Let H be a quasi-Hopf algebra.*

(i) *Let $V \in {}^H_H\mathcal{YD}$, with H -action denoted by \triangleright and H -coaction denoted by $V \rightarrow H \otimes V$, $v \mapsto v_{(-1)} \otimes v_{(0)}$. Then $V \otimes H$ becomes an object in ${}^H_H\mathcal{M}_H^H$ with structures:*

$$\begin{aligned} g \cdot (v \otimes h) \cdot k &= (g_1 \triangleright v) \otimes g_2 h k, \\ \lambda_{V \otimes H}(v \otimes h) &= X^1(x^1 \triangleright v)_{(-1)} x^2 h_1 \otimes (X^2 \triangleright (x^1 \triangleright v))_{(0)} \otimes X^3 x^3 h_2, \\ \rho_{V \otimes H}(v \otimes h) &= (x^1 \triangleright v \otimes x^2 h_1) \otimes x^3 h_2, \end{aligned}$$

for all $g, h, k \in H$ and $v \in V$.

(ii) *Let $M \in {}^H_H\mathcal{YD}$. Consider $V = M^{\text{co}(H)}$ as a left H -module with action \triangleright as in (A.1.32) and define the map $V \rightarrow H \otimes V$, $v \mapsto v_{<-1>} \otimes E(v_{<0>})$, where we have denoted the left H -coaction on M by $M \rightarrow H \otimes M$, $m \mapsto m_{<-1>} \otimes m_{<0>}$. Then with these structures V is an object in ${}^H_H\mathcal{YD}$, and if we regard $V \otimes H \in {}^H_H\mathcal{M}_H^H$ as in (i), the map $\nu : V \otimes H \rightarrow M$, $\nu(v \otimes h) = v \cdot h$ is an isomorphism in ${}^H_H\mathcal{M}_H^H$.*

For the sequel of this section, we fix a quasi-Hopf algebra H and an H -bicomodule algebra B , with structure maps λ_B, ρ_B and associators $\Phi_{\lambda_B}, \Phi_{\rho_B}, \Phi_{\lambda_B, \rho_B}$ such that there exists $v : H \rightarrow B$ a morphism of H -bicomodule algebras (in particular, this implies $\rho_B(v(h)) = v(h_1) \otimes h_2$, $\lambda_B(v(h)) = h_1 \otimes v(h_2)$, for all $h \in H$, and $\Phi_{\rho_B} = v(X^1) \otimes X^2 \otimes X^3$, $\Phi_{\lambda_B} = X^1 \otimes X^2 \otimes v(X^3)$ and $\Phi_{\lambda_B, \rho_B} = X^1 \otimes v(X^2) \otimes X^3$).

Lemma A.1.6. *(B, λ_B, ρ_B) becomes an object in ${}^H_H\mathcal{M}_H^H$.*

Proof. Obviously, B becomes an H -bimodule via v (i.e. $h \cdot b \cdot h' = v(h) b v(h')$ for all $h, h' \in H$ and $b \in B$). In [63, Lemma 2.3] it has been proved that $\rho_B : B \rightarrow B \otimes H$ is an H -bimodule map and that the conditions (A.1.26) and (A.1.27) for B are satisfied. Similarly one can prove that $\lambda_B : B \rightarrow H \otimes B$ is an H -bimodule map and that the conditions (A.1.28) and (A.1.29) for B are satisfied. Finally, the condition (A.1.30) is also satisfied, because it reduces to the condition (A.1.17) from the definition of an H -bicomodule algebra, due to the fact that $\Phi_{\lambda_B, \rho_B} = X^1 \otimes v(X^2) \otimes X^3$. \square

We can prove now the structure theorem for quasi-Hopf bicomodule algebras.

Theorem A.1.7. *Let H be a quasi-Hopf algebra, B an H -bicomodule algebra and $v : H \rightarrow B$ a morphism of H -bicomodule algebras. Regard $B \in {}^H_H\mathcal{M}_H^H$ as in Lemma A.1.6 and define $B_0 = B^{\text{co}(H)}$. Then B_0 is an algebra in ${}^H_H\mathcal{YD}$ and, if we regard $B_0 \# H$ as an H -bicomodule algebra as in Proposition A.1.3, then the map $\Psi : B_0 \# H \rightarrow B$, $\Psi(b \# h) = b v(h)$, is an isomorphism of H -bicomodule algebras.*

Proof. Since v is in particular a morphism of right H -comodule algebras, we know from [63] that B_0 endowed with a certain multiplication and with the H -action given by (A.1.32) becomes a left H -module algebra and the map $\Psi : B_0 \# H \rightarrow B$ defined

above is an isomorphism of right H -comodule algebras. It is very easy to see that Ψ respects the left and two-sided associators, so the only things left to prove are that B_0 is an algebra in ${}^H_H\mathcal{YD}$ and that Ψ intertwines the left H -coactions of B and $B_0\#H$. By Theorem A.1.5, we obtain that B_0 is an object in ${}^H_H\mathcal{YD}$ if we endow it with the coaction $b \mapsto b_{<-1>} \otimes E(b_{<0>}) := b_{(-1)} \otimes b_{(0)}$. Also, from Theorem A.1.5, we have that the map $\Psi : B_0 \otimes H \rightarrow B$ is a morphism in ${}^H_H\mathcal{M}_H^H$, in particular we have $\lambda_B \circ \Psi = (id_H \otimes \Psi) \circ \lambda_{B_0\#H}$, i.e. $\lambda_{B_0\#H} = (id_H \otimes \Psi^{-1}) \circ \lambda_B \circ \Psi$, where $\lambda_{B_0\#H}(b \otimes h) = X^1(x^1 \triangleright b)_{(-1)}x^2h_1 \otimes (X^2 \triangleright (x^1 \triangleright b)_{(0)} \otimes X^3x^3h_2)$. Since Ψ and λ_B are algebra maps, it follows that $\lambda_{B_0\#H}$ is also an algebra map. We can now apply Proposition A.1.4 to obtain that B_0 is an algebra in ${}^H_H\mathcal{YD}$. Finally, the fact that Ψ intertwines the left H -coactions on B and $B_0\#H$ follows from the fact that $\lambda_B \circ \Psi = (id_H \otimes \Psi) \circ \lambda_{B_0\#H}$ and the fact that the H -coaction of the comodule algebra $B_0\#H$, as defined in Proposition A.1.3, is exactly the map $\lambda_{B_0\#H}$ defined above. \square

A.2 Weak Hopf bicomodule algebras

Following [10], a *weak Hopf algebra* H is a linear space such that $(H, \mu, 1)$ is an associative unital algebra, (H, Δ, ε) is a coassociative counital coalgebra and there exists a k -linear map $S : H \rightarrow H$ (called the *antipode*), such that the following axioms hold:

$$\Delta(hh') = \Delta(h)\Delta(h'), \quad (\text{A.2.1})$$

$$\Delta^2(1) = (\Delta(1) \otimes 1)(1 \otimes \Delta(1)) = (1 \otimes \Delta(1))(\Delta(1) \otimes 1), \quad (\text{A.2.2})$$

$$\varepsilon(hh'h'') = \varepsilon(hh'_1)\varepsilon(h'_2h'') = \varepsilon(hh'_2)\varepsilon(h'_1h''), \quad (\text{A.2.3})$$

$$h_1S(h_2) = \varepsilon(1_1h)1_2, \quad (\text{A.2.4})$$

$$S(h_1)h_2 = 1_1\varepsilon(h1_2), \quad (\text{A.2.5})$$

$$S(h_1)h_2S(h_3) = S(h). \quad (\text{A.2.6})$$

for all $h, h', h'' \in H$. For a weak Hopf algebra H , there exist two idempotent maps $\varepsilon_t, \varepsilon_s : H \rightarrow H$ defined by $\varepsilon_t(h) = \varepsilon(1_1h)1_2$, $\varepsilon_s(h) = 1_1\varepsilon(h1_2)$, for all $h \in H$, called the *target map* and respectively the *source map*; their images, denoted by H_t and respectively H_s , are called the *target space* and respectively the *source space*.

For a weak Hopf algebra H , the following relations hold (see [10, 17] for proofs):

$$h_1S(h_2) = \varepsilon_t(h), \quad S(h_1)h_2 = \varepsilon_s(h), \quad (\text{A.2.7})$$

$$1_1 \otimes \varepsilon_t(1_2) = 1_1 \otimes 1_2 = \varepsilon_s(1_1) \otimes 1_2, \quad (\text{A.2.8})$$

$$\varepsilon_t(h\varepsilon_t(h')) = \varepsilon_t(hh'), \quad \varepsilon_s(\varepsilon_s(h)h') = \varepsilon_s(hh'), \quad (\text{A.2.9})$$

$$\Delta(H_t) \subseteq H \otimes H_t, \quad \Delta(H_s) \subseteq H_s \otimes H, \quad (\text{A.2.10})$$

$$h_1 \otimes \varepsilon_t(h_2) = 1_1h \otimes 1_2, \quad \varepsilon_s(h_1) \otimes h_2 = 1_1 \otimes h1_2, \quad (\text{A.2.11})$$

$$h\varepsilon_t(h') = \varepsilon(h_1h')h_2, \quad \varepsilon_s(h)h' = h'_1\varepsilon(hh'_2), \quad (\text{A.2.12})$$

$$\varepsilon_t(\varepsilon_t(h)h') = \varepsilon_t(h)\varepsilon_t(h'), \quad \varepsilon_s(h\varepsilon_s(h')) = \varepsilon_s(h)\varepsilon_s(h'), \quad (\text{A.2.13})$$

$$\varepsilon_t(h_1)h_2 = h = h_1\varepsilon_s(h_2), \quad (\text{A.2.14})$$

$$\Delta(1) = 1_1 \otimes \varepsilon_t(1_2) = \varepsilon_s(1_1) \otimes 1_2 \in H_s \otimes H_t, \quad (\text{A.2.15})$$

$$h_1 \otimes \varepsilon_s(h_2) = h_1 1_1 \otimes S(1_2), \quad \varepsilon_t(h_1) \otimes h_2 = S(1_1) \otimes 1_2 h, \quad (\text{A.2.16})$$

$$\varepsilon(h\varepsilon_t(h')) = \varepsilon(hh') = \varepsilon(\varepsilon_s(h)h'), \quad (\text{A.2.17})$$

for all $h, h' \in H$. Moreover, H_t and H_s are subalgebras of H (containing 1) and, for all $h \in H$, $y \in H_s$ and $z \in H_t$, the following relations hold:

$$yz = zy, \quad (\text{A.2.18})$$

$$\Delta(y) = 1_1 \otimes y 1_2 = 1_1 \otimes 1_2 y, \quad (\text{A.2.19})$$

$$\Delta(z) = 1_1 z \otimes 1_2 = z 1_1 \otimes 1_2, \quad (\text{A.2.20})$$

$$y 1_1 \otimes S(1_2) = 1_1 \otimes S(1_2) y, \quad (\text{A.2.21})$$

$$z S(1_1) \otimes 1_2 = S(1_1) \otimes 1_2 z, \quad (\text{A.2.22})$$

$$h_1 y \otimes h_2 = h_1 \otimes h_2 S(y), \quad (\text{A.2.23})$$

$$h_1 \otimes z h_2 = S(z) h_1 \otimes h_2. \quad (\text{A.2.24})$$

Let H be a weak Hopf algebra and assume $(A, \mu_A, 1_A)$ is an associative unital algebra. Then A is called a *left H -module algebra* (see for instance [58]) if A is a left H -module such that

$$h \cdot (ab) = (h_1 \cdot a)(h_2 \cdot b), \quad h \cdot 1_A = \varepsilon_t(h) \cdot 1_A, \quad (\text{A.2.25})$$

for all $h \in H$ and $a, b \in A$. If this is the case, we can define the *smash product* $A \# H$, which, as a linear space, is the (relative) tensor product $A \otimes_{H_t} H$, where H is a left H_t -module via multiplication and A is a right H_t -module as follows: $a \cdot z = a(z \cdot 1_A)$, for all $a \in A$, $z \in H_t$. $A \# H$ becomes an associative algebra with unit $1_A \# 1_H$ and multiplication defined by $(a \# h)(a' \# h') = a(h_1 \cdot a') \# h_2 h'$, for all $a, a' \in A$ and $h, h' \in H$, where we denoted by $a \# h$ the class of $a \otimes h$ in $A \otimes_{H_t} H$.

Definition A.2.1 ([9]). Let H be a weak Hopf algebra and $(A, \mu_A, 1_A)$ an associative unital algebra.

A is called a *right H -comodule algebra* if there is a linear map $\rho : A \rightarrow A \otimes H$ such that:

$$(id_A \otimes \varepsilon) \circ \rho = id_A, \quad (\text{A.2.26})$$

$$(\rho \otimes id_H) \circ \rho = (id_A \otimes \Delta) \circ \rho, \quad (\text{A.2.27})$$

$$\rho(1_A)(a \otimes 1_H) = ((id_A \otimes \varepsilon_t) \circ \rho)(a), \quad \forall a \in A, \quad (\text{A.2.28})$$

$$\rho(ab) = \rho(a)\rho(b), \quad \forall a, b \in A. \quad (\text{A.2.29})$$

Similarly, A is called a *left H -comodule algebra* if there is a linear map $\lambda : A \rightarrow H \otimes A$

such that:

$$(\varepsilon \otimes id_A) \circ \lambda = id_A, \quad (\text{A.2.30})$$

$$(id_H \otimes \lambda) \circ \lambda = (\Delta \otimes id_A) \circ \lambda, \quad (\text{A.2.31})$$

$$(1_H \otimes a)\lambda(1_A) = ((\varepsilon_s \otimes id_A) \circ \lambda)(a), \quad \forall a \in A, \quad (\text{A.2.32})$$

$$\lambda(ab) = \lambda(a)\lambda(b), \quad \forall a, b \in A. \quad (\text{A.2.33})$$

A is called an H -bicomodule algebra if it is a right and left H -comodule algebra and the coactions ρ and λ satisfy the bicomodule condition $(\lambda \otimes id_H) \circ \rho = (id_H \otimes \rho) \circ \lambda$. If A, B are two H -bicomodule algebras, a morphism of H -bicomodule algebras $f : A \rightarrow B$ is an algebra map intertwining the right and left coactions.

One can see that the condition (A.2.32) may be replaced by any of the following two equivalent conditions (that appear in [60], respectively [59]):

$$(\Delta \otimes id_A)(\lambda(1_A)) = (1_H \otimes \lambda(1_A))(\Delta(1_H) \otimes 1_A), \quad (\text{A.2.34})$$

$$\lambda(1_A) = (\varepsilon_s \otimes id_A)(\lambda(1_A)). \quad (\text{A.2.35})$$

If H is a weak Hopf algebra and A is a left H -module algebra, then $A\#H$ becomes a right H -comodule algebra, with coaction $\rho : A\#H \rightarrow (A\#H) \otimes H$, $\rho(a\#h) = (a\#h_1) \otimes h_2$.

Definition A.2.2 ([86]). Let H be a weak Hopf algebra. A *weak Hopf bimodule* M over H is a linear space which is an H -bimodule and an H -bicomodule such that the two coactions are morphisms of H -bimodules. The category whose objects are weak Hopf bimodules and morphisms are linear maps intertwining the bimodule and bicomodule structures is denoted by ${}^H_H\mathcal{M}_H^H$.

Similarly, we can define the category ${}_H\mathcal{M}_H^H$. If M is an object in this category, with H -module structures denoted by \cdot and right H -comodule structure denoted by $\rho(m) = m_{(0)} \otimes m_{(1)}$, define the map $E : M \rightarrow M$, $E(m) = m_{(0)} \cdot S(m_{(1)})$ and $M^{co(H)} := \{m \in M / \rho(m) = m_{(0)} \otimes \varepsilon_t(m_{(1)})\}$. Then by [89, 88], $M^{co(H)}$ is a left H -module with action:

$$h \triangleright m = E(h \cdot m), \quad \forall h \in H, m \in M^{co(H)}. \quad (\text{A.2.36})$$

Definition A.2.3 ([17]). Let H be a weak Hopf algebra. A *left-left Yetter-Drinfeld module over H* is a linear space M with a left H -module structure (denoted by $h \otimes m \mapsto h \cdot m$) and a left H -comodule structure (denoted by $m \mapsto m_{(-1)} \otimes m_{(0)} \in H \otimes M$) such that the following conditions are satisfied:

$$m_{(-1)} \otimes m_{(0)} = 1_1 m_{(-1)} \otimes 1_2 \cdot m_{(0)}, \quad (\text{A.2.37})$$

$$(h_1 \cdot m)_{(-1)} h_2 \otimes (h_1 \cdot m)_{(0)} = h_1 m_{(-1)} \otimes h_2 \cdot m_{(0)}. \quad (\text{A.2.38})$$

for all $h \in H, m \in M$. We denote by ${}^H_H\mathcal{YD}$ the category whose objects are Yetter-Drinfeld modules and morphisms are H -linear H -colinear maps.

Exactly as in the Hopf case, condition (A.2.38) may be replaced by the equivalent condition

$$(h \cdot m)_{(-1)} \otimes (h \cdot m)_{(0)} = h_1 m_{(-1)} S(h_3) \otimes h_2 \cdot m_{(0)}. \quad (\text{A.2.39})$$

Theorem A.2.4. *Assume that H is a weak Hopf algebra and A is a linear space such that is a (left-left) Yetter-Drinfeld module. Then $A\#H$ is an H -bicomodule algebra, with coactions*

$$\begin{aligned} \rho : A\#H &\rightarrow (A\#H) \otimes H, & \rho(a\#h) &= (a\#h_1) \otimes h_2, \\ \lambda : A\#H &\rightarrow H \otimes (A\#H), & \lambda(a\#h) &= a_{(-1)} h_1 \otimes (a_{(0)}\#h_2), \end{aligned}$$

and the linear map $j : H \rightarrow A\#H$, $j(h) = 1_A\#h$, is a morphism of H -bicomodule algebras.

Proof. Some of the conditions to be checked are trivial, we will prove only the non-trivial ones.

We begin by noting that, with a proof similar to the one in [57, Remark 2.6], and respectively as a consequence of (A.2.35), we have the following relations:

$$y \cdot a = \varepsilon(a_{(-1)}y)a_{(0)}, \quad \forall a \in A, y \in H_s, \quad (\text{A.2.40})$$

$$1_{A(-1)} \otimes 1_{A(0)} \in H_s \otimes A. \quad (\text{A.2.41})$$

We prove first that λ is well-defined, that is $\lambda(a\#zh) = \lambda(a(z \cdot 1_A)\#h)$, for all $a \in A$, $h \in H$, $z \in H_t$. We compute:

$$\begin{aligned} \lambda(a\#zh) &= a_{(-1)} z_1 h_1 \otimes (a_{(0)}\#z_2 h_2) \\ &= a_{(-1)} z_1 h_1 \otimes (a_{(0)}\#1_2 h_2) && \text{by (A.2.20)} \\ &= a_{(-1)} z h_1 \otimes (a_{(0)}\#h_2), \end{aligned}$$

$$\begin{aligned} \lambda(a(z \cdot 1_A)\#h) &= [a(z \cdot 1_A)]_{(-1)} h_1 \otimes ([a(z \cdot 1_A)]_{(0)}\#h_2) \\ &= a_{(-1)}(z \cdot 1_A)_{(-1)} h_1 \otimes (a_{(0)}(z \cdot 1_A)_{(0)}\#h_2) \\ &= a_{(-1)} z_1 1_{A(-1)} S(z_3) h_1 \otimes (a_{(0)}(z_2 \cdot 1_{A(0)})\#h_2) && \text{by (A.2.39)} \\ &= a_{(-1)} z_1 1_{A(-1)} S(1_3) h_1 \otimes (a_{(0)}(1_2 \cdot 1_{A(0)})\#h_2) && \text{by (A.2.20)} \\ &= a_{(-1)} z_1 1_{A(-1)} S(1_{2'}) h_1 \otimes (a_{(0)}(1_{1'} 1_2 \cdot 1_{A(0)})\#h_2) && \text{by (A.2.2)} \\ &= a_{(-1)} z_1 1_{A(-1)} S(1_2) h_1 \otimes (a_{(0)}(1_1 \cdot 1_{A(0)})\#h_2) && \text{by (A.2.37)} \\ &= a_{(-1)} z_1 1_{A(-1)} h_1 \otimes (a_{(0)}(1_1 \cdot 1_{A(0)})\#1_2 h_2) && \text{by (A.2.15), (A.2.24)} \\ &= a_{(-1)} z_1 1_{A(-1)} h_1 \otimes (a_{(0)}(1_1 \cdot 1_{A(0)})(1_2 \cdot 1_A)\#h_2) && \text{by (*)} \end{aligned}$$

$$\begin{aligned}
&= a_{(-1)}z1_{A(-1)}h_1 \otimes (a_{(0)}1_{A(0)}\#h_2) && \text{by (A.2.25)} \\
&= a_{(-1)}1_{A(-1)}zh_1 \otimes (a_{(0)}1_{A(0)}\#h_2) && \text{by (A.2.41), (A.2.18)} \\
&= a_{(-1)}zh_1 \otimes (a_{(0)}\#h_2),
\end{aligned}$$

where the equality (*) follows by using the fact that $A\#H$ is the tensor product over H_t . We prove now the counitality condition for λ , i.e. $\varepsilon(a_{(-1)}h_1)a_{(0)}\#h_2 = a\#h$, for all $a \in A$, $h \in H$. We compute:

$$\begin{aligned}
&\varepsilon(a_{(-1)}h_1)a_{(0)}\#h_2 \\
&= \varepsilon(a_{(-1)}1_1)\varepsilon(1_2h_1)a_{(0)}\#h_2 && \text{by (A.2.3)} \\
&= \varepsilon(1_2h_1)(1_1 \cdot a)\#h_2 && \text{by (A.2.15), (A.2.40)} \\
&= \varepsilon(1_21_1'h_1)(1_1 \cdot a)\#1_2'h_2 \\
&= \varepsilon(1_1'1_2h_1)(1_1 \cdot a)\#1_2'h_2 && \text{by (A.2.2)} \\
&= 1_1 \cdot a\#\varepsilon_t(1_2h_1)h_2 && \text{by (A.2.12)} \\
&= 1_1 \cdot a\#\varepsilon_t(\varepsilon_t(1_2)h_1)h_2 && \text{by (A.2.15)} \\
&= 1_1 \cdot a\#\varepsilon_t(1_2)\varepsilon_t(h_1)h_2 && \text{by (A.2.13)} \\
&= 1_1 \cdot a\#\varepsilon_t(1_2)h && \text{by (A.2.14)} \\
&= 1_1 \cdot a\#1_2h && \text{by (A.2.15)} \\
&= (1_1 \cdot a)(1_2 \cdot 1_A)\#h && \text{by (*)} \\
&= 1 \cdot (a1_A)\#h && \text{by (A.2.25)} \\
&= a\#h,
\end{aligned}$$

where again for proving the equality (*) we used the fact that the tensor product is over H_t .

We prove now the condition (A.2.32) in the definition of a left H -comodule algebra. As we have seen, this is equivalent to the condition (A.2.35), so it is enough to prove (A.2.35) for our λ , namely $\lambda(1_A\#1_H) = (\varepsilon_s \otimes id_A \otimes id_H)(\lambda(1_A\#1_H))$. We compute:

$$\begin{aligned}
&(\varepsilon_s \otimes id_A \otimes id_H)(\lambda(1_A\#1_H)) \\
&= (\varepsilon_s \otimes id_A \otimes id_H)(1_{A(-1)}1_1 \otimes (1_{A(0)}\#1_2)) \\
&= \varepsilon_s(1_{A(-1)}1_1) \otimes (1_{A(0)}\#1_2) \\
&= \varepsilon_s(1_{A(-1)}\varepsilon_s(1_1)) \otimes (1_{A(0)}\#1_2) && \text{by (A.2.15)} \\
&= \varepsilon_s(1_{A(-1)})\varepsilon_s(1_1) \otimes (1_{A(0)}\#1_2) && \text{by (A.2.13)} \\
&= \varepsilon_s(1_{A(-1)})1_1 \otimes (1_{A(0)}\#1_2) && \text{by (A.2.15)} \\
&= 1_{A(-1)}1_1 \otimes (1_{A(0)}\#1_2) && \text{by (A.2.35)} \\
&= \lambda(1_A\#1_H).
\end{aligned}$$

The only nontrivial thing left to prove is that the map j intertwines the left coactions, that is $1_{A(-1)}h_1 \otimes 1_{A(0)}\#h_2 = h_1 \otimes 1_A\#h_2$, for all $h \in H$. We compute:

$$\begin{aligned}
& 1_{A(-1)}h_1 \otimes 1_{A(0)}\#h_2 \\
&= \varepsilon_s(1_{A(-1)})h_1 \otimes 1_{A(0)}\#h_2 && \text{by (A.2.35)} \\
&= h_1 \otimes \varepsilon(1_{A(-1)}h_2)1_{A(0)}\#h_3 && \text{by (A.2.12)} \\
&= h_1 \otimes \varepsilon(1_{A(-1)}\varepsilon_t(h_2))1_{A(0)}\#h_3 && \text{by (A.2.17)} \\
&= h_1 \otimes \varepsilon(1_{A(-1)}S(1_1))1_{A(0)}\#1_2h_2 && \text{by (A.2.16)} \\
&= h_1 \otimes [\varepsilon(1_{A(-1)}S(1_1))1_{A(0)}][1_2 \cdot 1_A]\#h_2 && \text{by (*)} \\
&= h_1 \otimes [\varepsilon(1_{A(-1)}1_1)1_{A(0)}][1_2 \cdot 1_A]\#h_2 && \text{by (A.2.16), (A.2.17)} \\
&= h_1 \otimes [1_1 \cdot 1_A][1_2 \cdot 1_A]\#h_2 && \text{by (A.2.15), (A.2.40)} \\
&= h_1 \otimes 1_A\#h_2 && \text{by (A.2.25)}
\end{aligned}$$

where again for proving the equality (*) we used the fact that the tensor product is over H_t . \square

Let H be a weak Hopf algebra with bijective antipode. It was proved in [87] that there exists an equivalence of categories between ${}^H_H\mathcal{M}_H^H$ and the category of right-right Yetter-Drinfeld modules over H . We will need the left-handed analogue of this result, whose proof is analogous to the one in [87].

Proposition A.2.5. *Let H be a weak Hopf algebra with bijective antipode.*

(i) *Let $V \in {}^H_H\mathcal{YD}$, with H -action denoted by \triangleright and H -coaction $V \rightarrow H \otimes V$, $v \mapsto v_{(-1)} \otimes v_{(0)}$. Then $V \otimes_{H_t} H$ becomes an object in ${}^H_H\mathcal{M}_H^H$ with structures:*

$$\begin{aligned}
g \cdot (v \otimes h) &= g_1 \triangleright v \otimes g_2 h, & (v \otimes h) \cdot k &= v \otimes hk, \\
\lambda_{V \otimes_{H_t} H}(v \otimes h) &= v_{(-1)}h_1 \otimes (v_{(0)} \otimes h_2), \\
\rho_{V \otimes_{H_t} H}(v \otimes h) &= (v \otimes h_1) \otimes h_2,
\end{aligned}$$

for all $g, h, k \in H$ and $v \in V$, where V is regarded as a right H_t -module by the formula $v \cdot z = S(z) \triangleright v$, for all $v \in V$ and $z \in H_t$.

(ii) *Let $M \in {}^H_H\mathcal{M}_H^H$. Consider $V = M^{co(H)}$ as a left H -module with action \triangleright as in (A.2.36) and define the map $V \rightarrow H \otimes V$, $v \mapsto v_{<-1>} \otimes v_{<0>}$, where we denoted by $M \rightarrow H \otimes M$, $m \mapsto m_{<-1>} \otimes m_{<0>}$ the left H -coaction on M . Then with these structures V is an object in ${}^H_H\mathcal{YD}$, and if we regard $V \otimes_{H_t} H \in {}^H_H\mathcal{M}_H^H$ as in (i), the map $\nu : V \otimes_{H_t} H \rightarrow M$, $\nu(v \otimes h) = v \cdot h$ is an isomorphism in ${}^H_H\mathcal{M}_H^H$.*

We now fix a weak Hopf algebra H with bijective antipode and an H -bicomodule algebra B , with coactions λ_B and ρ_B such that there exists a morphism of H -bicomodule algebras $\nu : H \rightarrow B$. If we set consider the actions $h \cdot b = \nu(h)b$ and $b \cdot h = b\nu(h)$, for all $h \in H$ and $b \in B$, then B becomes an object in ${}^H_H\mathcal{M}_H^H$.

Hence we can consider the coinvariants $B_0 = B^{co(H)}$. By [89, 88] we know that $(B_0, \triangleright, 1_B)$ is a left H -module algebra (where the action \triangleright is defined as above by

$h \triangleright b = E(h \cdot b) = E(v(h)b)$, for all $h \in H$, $b \in B_0$, and the multiplication of B_0 is the restriction to B_0 of the multiplication of B and the map $\phi : B_0 \# H \rightarrow B$, $\phi(b \# h) = bv(h)$ is an isomorphism of right H -comodule algebras. By Proposition A.2.5 we know that B_0 is an object in ${}^H_H\mathcal{YD}$.

Theorem A.2.6. *With notation as above, B_0 is also a left H -comodule algebra, and if we regard $B_0 \# H$ as an H -bicomodule algebra as in Theorem A.2.4 then the map $\phi : B_0 \# H \rightarrow B$, $\phi(b \# h) = bv(h)$ is an isomorphism of H -bicomodule algebras.*

Proof. B_0 is a left H -comodule algebra because its multiplication and left H -comodule structure are the restrictions of the ones of B , the unit of A is the same as the unit of B and B is a left H -comodule algebra. So the only thing left to prove is that the map ϕ intertwines the left H -coactions on $B_0 \# H$ and B , and this follows by a straightforward computation using the fact that $\lambda_B(v(h)) = h_1 \otimes v(h_2)$, for all $h \in H$. \square

Bibliography

- [1] H. Albuquerque and F. Panaite, *On quasi-Hopf smash products and twisted tensor products of quasialgebras*, *Algebr. Represent. Th.* **12** (2009), 199–234.
- [2] A. Alvarez and F. Vilaboa, *Cleft extensions in braided categories*, *Comm. Algebra* **28** (2000), 3185–3196.
- [3] N. Andruskiewitsch and J.M. Mombelli, *On module categories over finite-dimensional Hopf algebras*, *J. Algebra* **314** (2007), 383–418.
- [4] M. Auslander and O. Goldman, *The Brauer group of a commutative ring*, *Trans. Amer. Math. Soc.* **97** (1960), 367–409.
- [5] M. Beattie, *A direct sum decomposition for the Brauer group of H -module algebras*, *J. Algebra* **43** (1976), 686–693.
- [6] Y. Bespalov, *Crossed modules and quantum groups in braided categories*, *Appl. Categor. Struct.* **5** (1997), 155–204.
- [7] Y. Bespalov and B. Drabant, *Hopf (bi)-modules and crossed modules in braided monoidal categories*, *J. Pure Appl. Algebra* **123** (1998), 105–129.
- [8] J. Bichon and G. Carnovale, *Lazy cohomology: An analogue of the Schur multiplier for arbitrary Hopf algebras*, *J. Pure Appl. Algebra* **204** (2006), 627–665.
- [9] G. Böhm, *Doi-Hopf modules over weak Hopf algebras*, *Comm. Algebra* **28** (2000), 4687–4698.
- [10] G. Böhm, F. Nill, and K. Szlachányi, *Weak Hopf algebras I: Integral theory and C^* -structure*, *J. Algebra* **221** (1999), 385–438.
- [11] D. Bulacu, F. Panaite, and F. Van Oystaeyen, *Quasi-Hopf algebra actions and smash products*, *Comm. Algebra* **28** (2000), 631–651.

-
- [12] S. Caenepeel, *Brauer groups, Hopf algebras and Galois theory*, K-Monographs in Mathematics, Kluwer Academic Publishers, Dordrecht, 1998.
- [13] S. Caenepeel and F. Grandjean, *A note on Taylor's Brauer group*, Pacific J. Math. **186** (1998), 13–27.
- [14] S. Caenepeel, F. Van Oystaeyen, and Y.H. Zhang, *Quantum Yang-Baxter module algebras*, K-Theory **8** (1994), 231–255.
- [15] S. Caenepeel, F. Van Oystaeyen, and Y.H. Zhang, *The Brauer group of Yetter-Drinfel'd module algebras*, Trans. Amer. Math. Soc. **349** (1997), 3737–3771.
- [16] S. Caenepeel, F. Van Oystaeyen, and Y.H. Zhang, *The equivariant Brauer group of a group*, Proc. Amer. Math. Soc. **134** (2005), 959–972.
- [17] S. Caenepeel, D. Wang, and Y. Yin, *Yetter-Drinfeld modules over weak bialgebras*, Ann. Univ. Ferrara - Sez. VII - Sc. Mat. **LI** (2005), 69–98.
- [18] G. Carnovale, *Some isomorphisms for the Brauer groups of a Hopf algebra*, Comm. Algebra **29** (2001), 5291–5305.
- [19] G. Carnovale, *The Brauer group of modified supergroup algebras*, J. Algebra **305** (2006), 993–1036.
- [20] G. Carnovale and J. Cuadra, *Cocycle twisting of $E(n)$ -module algebras and applications to the Brauer group*, K-Theory **3** (2004), 251–276.
- [21] S. Chase and M. E. Sweedler, *Hopf algebras and Galois theory*, Lecture Notes in Mathematics **97**, Springer-Verlag, Berlin, 1969.
- [22] L.N. Childs, *The Brauer group of graded Azumaya algebras II: Graded Galois extensions*, Trans. Amer. Math. Soc. **204** (1975), 137–160.
- [23] L.N. Childs, G. Garfinkel, and M. Orzech, *The Brauer group of graded Azumaya algebras*, Trans. Amer. Math. Soc. **175** (1973), 299–326.
- [24] J. Cuadra and B. Femić, *A sequence to compute the Brauer group of certain quasi-triangular Hopf algebras*, Appl. Categor. Struct. **20** (2012), 433–512.
- [25] J. Cuadra and F. Panaite, *Extending lazy 2-cocycles on Hopf algebras and lifting projective representations afforded by them*, J. Algebra **313** (2007), 695–723.
- [26] A. Davydov and D. Nikshych, *The Picard crossed module of a braided tensor category*, arXiv: math.QA/1202.0061, 2013.
- [27] P. Deligne, *Catégories tannakiennes*, The Grothendieck Festschrift Volume II (1990), 111–195.

-
- [28] J. Dello, F. Panaite, F. Van Oystaeyen, and Y.H. Zhang, *Structure theorems for bicomodule algebras over quasi-Hopf algebras, weak Hopf algebras and braided Hopf algebras*, arXiv:math.QA/1310.4680, 2014.
- [29] J. Dello and Y.H. Zhang, *Extending bi-Galois objects and automorphisms to the Radford biproduct*, Preprint.
- [30] J. Dello and Y.H. Zhang, *Monoidal equivalences and the equivariant Brauer group of a quasitriangular Hopf algebra*, In preparation.
- [31] J. Dello and Y.H. Zhang, *The equivariant Brauer group of a cocommutative Hopf algebra*, *Comm. Algebra* **41** (2013), 4161–4194.
- [32] F. DeMeyer and E. Ingraham, *Separable algebras over commutative rings*, *Lecture Notes in Mathematics*, vol. 181, Springer-Verlag, 1971.
- [33] Y. Doi, *Equivalent crossed products for a Hopf algebra*, *Comm. Algebra* **17** (1989), 3053–3085.
- [34] B. Drabant and A. Van Daele, *Pairing and quantum double of multiplier Hopf algebras*, *Algebr. Represent. Theory* **4** (2001), 109–132.
- [35] B. Drabant, A. Van Daele, and Y.H. Zhang, *Actions of multiplier Hopf algebras*, *Comm. Algebra* **27** (1999), 4117–4172.
- [36] V. G. Drinfeld, *Quasi-Hopf algebras*, *Leningrad Math. J.* **1** (1990), 1419–1457.
- [37] P. Etingof, S. Gelaki, D. Nikshych, and V. Ostrik, *Finite tensor categories*, *Mosc. Math. J.* **4** (2004), 627–654.
- [38] P. Etingof, D. Nikshych, and V. Ostrik, *Fusion categories and homotopy theory*, *Quantum Topol.* **1** (2010), 209–273.
- [39] B. Femić, *Azumaya corings, braided Hopf-Galois theory and Brauer groups*, Ph.D. thesis, Universidad de Almería and Vrije Universiteit Brussel, 2008.
- [40] J. Greenough, *Monoidal 2-structure of bimodule categories*, *J. Algebra* **324** (2010), 1818–1859.
- [41] F. Hausser and F. Nill, *Integral theory for quasi-Hopf algebras*, arXiv:math.QA/9904164.
- [42] F. Hausser and F. Nill, *Diagonal crossed products by duals of quasi-quantum groups*, *Rev. Math. Phys.* **11** (1999), 553–629.
- [43] K. Janssen and J. Vercautse, *Multiplier Hopf and bi-algebras*, *J. Algebra Appl.* **9** (2010), 275–303.

-
- [44] A. Joyal and R. Street, *Braided monoidal categories*, Macquarie Mathematical Reports (1986), no. 860081.
- [45] A. Joyal and R. Street, *Braided tensor categories*, Adv. Math. **102** (1993), 20–78.
- [46] H.F. Kreimer and M. Takeuchi, *Hopf algebras and Galois extensions of an algebra*, Indiana Univ. Math. J. **30** (1981), 675–692.
- [47] R.G. Larson, *Hopf algebra orders determined by group valuations*, J. Algebra **38** (1976), 414–452.
- [48] F.W. Long, *The Brauer group of dimodule algebras*, J. Algebra **31** (1974), 559–601.
- [49] V. Lyubashenko, *Tangles and Hopf algebras in braided categories*, J. Pure Appl. Algebra **98** (1995), 245–278.
- [50] S. Mac Lane, *Categories for the working mathematician (second edition)*, Graduate Texts in Mathematics, vol. 5, Springer Verlag, Berlin, 1998.
- [51] S. Majid, *Reconstruction theorems and rational conformal field theories*, Int. J. Mod Phys. **6** (1991), 4359–4374.
- [52] S. Majid, *Braided groups*, J. Pure Appl. Algebra **86** (1993), 187–221.
- [53] S. Majid, *Transmutation theory and rank for quantum braided groups*, Math. Proc. Camb. Phil. Soc. **113** (1993), 45–70.
- [54] S. Majid, *Algebras and Hopf algebras in braided categories*, Advances in Hopf Algebras, Lecture Notes in Pure and Appl. Math. **158** (1994), 55–105.
- [55] S. Majid, *Cross products by braided groups and bosonization*, J. Algebra **163** (1994), 165–190.
- [56] S. Majid, *Quantum double for quasi-Hopf algebras*, Lett. Math. Phys. **45** (1998), 1–9.
- [57] A. Nenciu, *The center construction for weak Hopf algebras*, Tsukuba J. Math. **26** (2002), 189–204.
- [58] D. Nikshych, *A duality theorem for quantum groupoids*, Contemp. Math. **267** (2000), 237–244.
- [59] D. Nikshych and L. Vainerman, *Finite quantum groupoids and their applications*, New directions in Hopf algebras, MSRI Publications **43** (2002), 211–262.
- [60] F. Nill, K. Szlachányi, and H.-W. Wiesbrock, *Weak Hopf algebras and reducible Jones inclusions of depth 2. I: From crossed products to Jones towers*, arXiv:math.QA/9806130.

-
- [61] V. Ostrik, *Module categories, weak Hopf algebras and modular invariants*, Transform. Groups **8** (2003), 177–206.
- [62] F. Van Oystaeyen and Y.H. Zhang, *Embedding the Hopf automorphism group into the Brauer group*, Canad. Math. Bull. **41** (1998), 359–367.
- [63] F. Panaite and F. Van Oystaeyen, *A structure theorem for quasi-Hopf comodule algebras*, Proc. Amer. Math. Soc. **135** (2007), 1669–1677.
- [64] B. Pareigis, *Non-additive ring and module theory IV: The Brauer group of a symmetric monoidal category*, Lecture Notes in Mathematics **549** (1976), 112–133.
- [65] D.E. Radford, *The structure of Hopf algebras with a projection*, J. Algebra **92** (1985), 322–347.
- [66] L. Roberts, *The flat cohomology of group schemes of rank p* , Amer. J. Math. **95** (2011), 688–702.
- [67] P. Schauenburg, *Hopf modules and Yetter-Drinfeld modules*, J. Algebra **169** (1994), 874–890.
- [68] P. Schauenburg, *Hopf bigalois extensions*, Comm. Algebra **24** (1996), 3797–3825.
- [69] P. Schauenburg, *Bigalois objects over the Taft algebras*, Israel J. Math. **115** (200), 101–123.
- [70] P. Schauenburg, *Hopf bimodules, coquasibialgebras, and an exact sequence of Kac*, Adv. Math. **165** (2002), 194–263.
- [71] P. Schauenburg, *Hopf modules and the double of a quasi-Hopf algebra*, Trans. Amer. Math. Soc. **354** (2002), 3349–3378.
- [72] P. Schauenburg, *Hopf-Galois and bi-Galois extensions*, Fields Inst. Commun. **43** (2004), 469–515.
- [73] P. Schauenburg, *Braided bi-Galois theory*, Ann. Univ. Ferrara Sez. VII **51** (2005), 119–149.
- [74] P. Schauenburg, *Braided bi-Galois theory II: The cocommutative case*, J. Algebra **324** (2010), 3199–3218.
- [75] J. Tate and F. Oort, *Group schemes of prime order*, Ann. Sci. Éc. Norm. Supér. (4) **3** (1970), 1–21.
- [76] J. L. Taylor, *A bigger Brauer group*, Pacific J. Math. **103** (1982), 163–203.
- [77] K.-H. Ulbrich, *Galois extensions as functors of comodules*, Manuscripta Math. **59** (1987), 391–397.

-
- [78] K.-H. Ulbrich, *An exact sequence for the Brauer group of dimodule Azumaya algebras*, J. Okayama Univ. **35** (1993), 63–88.
- [79] R. Underwood, *The group of Galois extensions over orders in KC_{p^2}* , Trans. Amer. Math. Soc. **349** (2011), 1503–1514.
- [80] A. Van Daele, *Multiplier Hopf algebras*, Trans. Amer. Math. Soc. **342** (1994), 917–932.
- [81] A. Van Daele, *An algebraic framework for group duality*, Adv. Math. **140** (1998), 323–366.
- [82] A. Van Daele and Y.H. Zhang, *Galois theory for multiplier Hopf algebras with integrals*, Algebr. Represent. Theory **2** (1999), 83–106.
- [83] F. Van Oystaeyen and Y.H. Zhang, *Bi-Galois objects form a group*, unpublished, 1993.
- [84] F. Van Oystaeyen and Y.H. Zhang, *Galois-type correspondences for Hopf Galois extensions*, K-Theory **8** (1994), 257–269.
- [85] F. Van Oystaeyen and Y.H. Zhang, *The Brauer group of a braided monoidal category*, J. Algebra **202** (1998), 96–128.
- [86] S.-H. Wang, *Cibils-Rosso’s theorem for quantum groupoids*, Comm. Algebra **32** (2004), 3703–3722.
- [87] S.-H. Wang and H.-X. Zhu, *On braided Lie structures of algebras in the categories of weak Hopf bimodules*, Algebra Colloq. **17** (2010), 685–698.
- [88] Y. Yin and M. Zhang, *The structure theorem for weak Hopf algebras*, Adv. Math. (China) **38** (2009), 707–714.
- [89] L.-Y. Zhang, *The structure theorem of weak comodule algebras*, Comm. Algebra **38** (2010), 254–260.
- [90] Y.H. Zhang, *The quantum double of a coFrobenius Hopf algebra*, Comm. Algebra **27** (1999), 1413–1427.
- [91] Y.H. Zhang, *An exact sequence for the Brauer group of a finite quantum group*, J. Algebra **272** (2004), 321–378.
- [92] H. Zhu, *Brauer groups of braided fusion categories*, Ph.D. thesis, Universiteit Hasselt, 2012.

Index

- algebra, 7
 - associativity law, 8
 - Azumaya, 12
 - Brauer equivalent, 13
 - center, 134
 - idempotent, 134
 - Morita equivalent, 135
 - H -Morita equivalent, 137
 - morphism, 8
 - multiplication, 8
 - opposite, 12
 - strongly inner, 149
 - Taylor-Azumaya, 134
 - H -module, 136
 - unit, 8
 - unital, 134
- associativity constraint, 1
- bialgebra, 9
 - morphism, 9
- braiding, 3
 - reversed braiding, 7
- Brauer group, 13
- Brauer-Picard group, 112
- coalgebra, 8
 - coassociativity law, 8
 - comultiplication, 8
 - counit, 8
 - morphism, 8
- cocycle, 45
- coinner, 38
- cointernal, 47
- coinvariant subobject, 15
- comodule, 10
 - algebra, 14, 167, 173
 - bicomodule, 10
 - algebra, 15
 - cocommutative, 115
 - diagonal coaction, 14
 - morphism, 10
- coquasitriangular, 6
- cotensor product, 15
- equivariant Brauer group, 137
- faithfully projective, 11
- finite, 11
- flat, 14
 - faithfully, 14
- Galois object, 15
 - bi-Galois object, 31
 - quantum commutative, 116
- Hexagon axioms, 3
- Hopf algebra, 9
 - antipode, 9
 - cocommutative, 41
 - morphism, 9
- Hopf module, 23
 - Hopf bimodule, 24
 - two-fold, 24

- lazy, 46
 - almost lazy, 48
- lazy cohomology group, 46
- left dual, 11
- module, 9
 - algebra, 20, 166
 - bimodule, 10
 - diagonal action, 20
 - dual pair, 135
 - elementary algebra, 135
 - morphism, 10
 - unital, 134
- module category, 53
 - bimodule category, 54
 - invertible, 112
 - one-sided, 112
 - exact, 112
 - module functor, 54
- monoidal category, 1
 - braided, 2
 - closed, 11
 - rigid, 11
 - strict, 2
 - symmetric, 3
- monoidal equivalence, 5
 - braided, 5
 - trivializable, 53
- monoidal functor, 3
 - braided, 4
 - strict, 4
 - strong, 4
- monoidal natural transformation, 4
- multiplier, 137
- multiplier Hopf algebra, 139
 - algebraic quantum group, 140
 - antipode, 139
 - comultiplication, 139
 - counit, 139
 - integral, 140
 - regular, 139
- Pentagon axiom, 2
- Picard group, 112
- quasi-bialgebra, 166
 - associator, 166
 - comultiplication, 166
 - counit, 166
- quasi-Hopf algebra, 166
- quasi-Hopf bimodule, 170
- quasitriangular, 6
 - R -matrix, 6
- Radford biproduct, 69
- smash product, 20, 166, 173
- split idempotent, 23
- tensor product, 1
- Triangle axiom, 2
- unit constraint, 1
- unit object, 1
- weak Hopf algebra, 172
 - antipode, 172
 - source map, 172
 - source space, 172
 - target map, 172
 - target space, 172
- weak Hopf bimodule, 174
- Yetter-Drinfeld module, 5
 - braided, 20
 - quasi-Hopf, 168
 - weak Hopf, 174

