

Desert Road Archaeology

HEINRICH-BARTH-INSTITUT



Institut für Ur- und Frühgeschichte der Universität zu Köln

Forschungsstelle Afrika

27 A F R I C A P R A E H I S T O R I C A

Monographien zur Archäologie und Umwelt Afrikas

Monographs on African Archaeology and Environment

Monographies sur l'Archéologie et l'Environnement d'Afrique

Edited by Rudolph Kuper

KÖLN 2013

Desert Road Archaeology in Ancient Egypt and Beyond

Edited by Frank Förster & Heiko Riemer

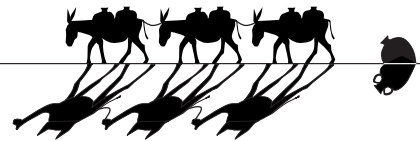

H E I N R I C H - B A R T H - I N S T I T U T

© HEINRICH-BARTH-INSTITUT e.V., Köln 2013
Jennerstr. 8, D-50823 Köln

<http://www.hbi-ev.uni-koeln.de>

This book is in copyright. No reproduction of any part may take place without the written permission of the publisher.

Bibliographic information published by
Die Deutsche Bibliothek

The Deutsche Bibliothek lists this publication in the Deutsche Nationalbibliographie; detailed bibliographic data are available on the Internet at <http://dnb.ddb.de>

Financed by Heinrich-Barth-Institut e.V.

Printed in Germany by Hans Kock GmbH, Bielefeld
Typeset and layout: Heiko Riemer
Copy editors: Elizabeth Hart and Rachel Herbert

Set in Palatino

ISBN 978-3-927688-41-4
ISSN 0947-2673

Contents

Prologue by <i>Rudolph Kuper</i>	10
Foreword by <i>Steven E. Sidebotham</i>	12
Editors' preface	14

Introduction

1	<i>Heiko Riemer & Frank Förster</i> Ancient desert roads: Towards establishing a new field of archaeological research	19
---	---	----

Methods, approaches, and historical perspectives

2	<i>Olaf Bubbenzer & Andreas Bolten</i> Top down: New satellite data and ground-truth data as base for a reconstruction of ancient caravan routes. Examples from the Western Desert of Egypt	61
3	<i>Heiko Riemer</i> Lessons in landscape learning: The dawn of long-distance travel and navigation in Egypt's Western Desert from prehistoric to Old Kingdom times	77
4	<i>Heidi Köpp</i> Desert travel and transport in ancient Egypt. An overview based on epigraphic, pictorial and archaeological evidence	107
5	<i>Klaus Peter Kuhlmann</i> The realm of "two deserts": Siwah Oasis between east and west	133
6	<i>Meike Meerpohl</i> Footprints in the sand: Recent long-distance camel trade in the Libyan Desert (northeast Chad/southeast Libya)	167
7	<i>Frank Förster, Heiko Riemer & Moez Mahir, with an appendix by Frank Darius</i> Donkeys to El-Fasher or how the present informs the past	193

Roads and regions I: Egypt's Western Desert, and Bayuda

- 8 *John Coleman Darnell, with the assistance of Deborah Darnell*
The Girga Road: Abu Ziyâr, Tundaba, and the integration of the
southern oases into the Pharaonic state 221
- 9 *Corinna Rossi & Salima Ikram*
Evidence of desert routes across northern Kharga (Egypt's Western Desert) 265
- 10 *Laure Pantalacci*
Broadening horizons: Distant places and travels in Dakhla and the
Western Desert at the end of the 3rd millennium 283
- 11 *Frank Förster*
Beyond Dakhla: The Abu Ballas Trail in the Libyan Desert (SW Egypt) 297
- 12 *Stan Hendrickx, Frank Förster & Merel Eyckerman*
The Pharaonic pottery of the Abu Ballas Trail: 'Filling stations' along a desert
highway in southwestern Egypt 339
- 13 *András Zboray*
Prehistoric trails in the environs of Karkur Talh, Jebel Uweinat 381
- 14 *Heinz-Josef Thissen*
Donkeys and water: Demotic ostraca in Cologne as evidence for desert travel
between Oxyrhynchos and the Bahariya Oasis in the 2nd century BC 391
- 15 *Per Storemyr, Elizabeth Bloxam, Tom Heldal & Adel Kelany*
Ancient desert and quarry roads on the west bank of the Nile in the
First Cataract region 399
- 16 *Angelika Lohwasser*
Tracks in the Bayuda desert. The project 'Wadi Abu Dom Itinerary' (W.A.D.I.) 425

Roads and regions II: Cyrenaica, Marmarica, Sinai, and Arabian Peninsula

- 17 *Steven Snape*
A stroll along the corniche? Coastal routes between the Nile Delta and
Cyrenaica in the Late Bronze Age 439
- 18 *Thomas Vetter, Anna-Katharina Rieger & Heike Möller*
Water, routes and rangelands: Ancient traffic and grazing infrastructure in the
eastern Marmarica (northwestern Egypt) 455
- 19 *James K. Hoffmeier & Stephen O. Moshier*
“A highway out of Egypt”: The main road from Egypt to Canaan 485
- 20 *Claire Somaglino & Pierre Tallet*
A road to the Arabian Peninsula in the reign of Ramesses III 511

Roads and regions III: Egypt’s Eastern Desert

- 21 *Ian Shaw*
“We went forth to the desert...”: Retracing the routes between the
Nile Valley and the Hatnub travertine quarries 521
- 22 *Kathryn A. Bard, Rodolfo Fattovich & Andrea Manzo*
The ancient harbor at Mersa/Wadi Gawasis and how to get there:
New evidence of Pharaonic seafaring expeditions in the Red Sea 533
- 23 *Adam Bülow-Jacobsen*
Communication, travel, and transportation in Egypt’s Eastern Desert during
Roman times (1st to 3rd century AD) 557
- Road index 575
- Contributors 577

The Pharaonic pottery of the Abu Ballas Trail: 'Filling stations' along a desert highway in southwestern Egypt

Abstract

The Abu Ballas Trail in the Libyan Desert (SW Egypt) consists of about thirty archaeological sites along an ancient donkey caravan route, and runs almost straight from Dakhla Oasis towards the Gilf Kebir Plateau, covering about 400 km. Large storage jars for water are the main finds at these sites, and the jars occur in varying numbers and different states of preservation. Through study of the pottery, several chronological phases of trail use have been recognized. The earliest use dates to the late Old Kingdom or early First Intermediate Period (around 2200/2100 BC). It is the best documented period because pottery from that time has been found at nearly all of the sites, although the amount of vessels and the composition of the types varies.

No doubt the variability in vessel amounts and types is due to functional differences between the individual sites. The donkeys must have been watered at the main stations, including the eponymous Abu Ballas or 'Pottery Hill' site, because of the large amount of storage jars found there (up to more than a hundred). The distances between the main supply depots are roughly equal and most probably relate to the donkey's ability to go without water for two or three days. Vats and different types of cups and bowls illustrate the organisation of the people accompanying the caravans and/or the men stationed at the individual sites to keep watch over the provisions. The intermittent sites contain far less pottery and can be considered temporary camp sites or places where vessels accidentally broken during transport were left behind.

The fabrics and vessel shapes of the late Old Kingdom / early First Intermediate Period are strikingly similar to those from the residence of the Egyptian governors at Balat/Ayn Asil in the eastern part of Dakhla, where the Abu Ballas Trail apparently had its departure point. There are, as yet, no vessels of the Middle Kingdom and only very few that can be attributed to the Second Intermediate Period, but two different phases of the New Kingdom are well represented: the later 18th dynasty and the Ramesside Period.

In addition to a general presentation of the pottery found along the trail, this article will focus on an ancient 'technique' of long-distance desert travel: the use of pottery deposits as artificial water reservoirs in order to facilitate the crossing of barren desert regions. This 'technique' has even been reported by Herodotus (III, 6–7) and the Abu Ballas Trail is currently the best example.

Keywords: pottery deposit, supply station, donkey caravan, Libyan Desert, Dakhla, Gilf Kebir, Sheikh Muf-tah culture, Old Kingdom, First Intermediate Period, Second Intermediate Period, New Kingdom, Roman

1. Introduction

During a geological survey in 1918, and later, in 1923, a collection of more than a hundred large pottery jars was found at the foot of a prominent sandstone hill, about 500 km west of the Nile and 200 km southwest of the Dakhla Oasis, the nearest water source (Ball 1927: 122, n. †; Kemal el-Dine &

Franchet 1927; Jarvis 1936: 114–116). Accordingly, the site was called "Abu Ballas" in Arabic, i.e. "Father of jars" (or "Pottery Hill"). Initially, there was much speculation about the age, origin, and purpose of these jars. After the discovery on the Abu Ballas hill of two rock engravings which date back to Pharaonic times (Rhotert 1952: pl. XXXVI,3–6; cf. Förster, this volume: figs. 17; 18) it has been in-

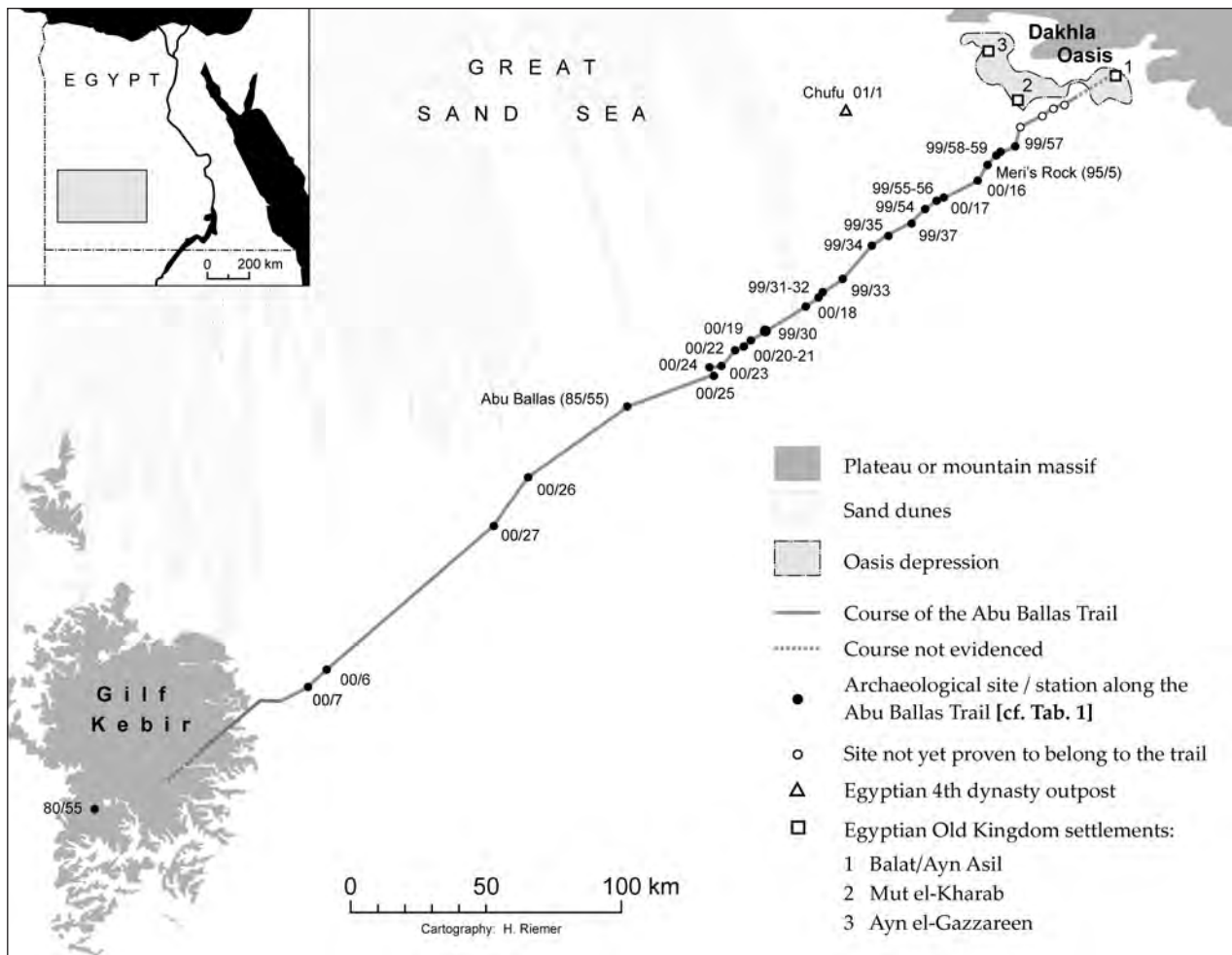

Fig. 1 Map of the Abu Ballas Trail and its archaeological sites.

creasingly assumed that at least part of the vessels dates to that period. The reason for the presence of this huge amount of pottery at such a remote place remained, for a very long time, one of the mysteries of the Libyan Desert (cf. Sers 1994: 198–207; Förster 2011: chapter 2). This situation changed in 1999/2000 when Carlo Bergmann, a dedicated German desert traveller who used camels to explore the unknown, discovered several new sites with similar deposits of pottery (cf. Bergmann 2001: 367–460). He identified about 30 sites, which are located along an almost perfectly straight line c. 360 km long from Dakhla to the outskirts of the Gilf Kebir Plateau [Fig. 1]. The most important of these pottery concentrations should be considered water depots, placed at rather regular distances in order to enable donkey caravans to travel through the barren desert. With the other, smaller sites, they make up

a chain of staging posts or depots and prove the existence of a Pharaonic desert route leading deep into the Libyan Desert, and probably continuing into sub-Saharan regions. Since winter 1999/2000, the sites have been under investigation by the ACACIA project (“Arid Climate, Adaptation and Cultural Innovation in Africa”), a Collaborative Research Centre (389) at the University of Cologne funded by the Deutsche Forschungsgemeinschaft from 1995 until 2007. The ACACIA project aimed to elucidate the purpose and destination of this ancient caravan route that has been labelled the “Abu Ballas Trail” (Kuper 2001; 2002; 2003a; 2003b; Kuhlmann 2002: 149–158; Schönfeld 2004; Förster 2007a; 2007b; 2010; 2011; Förster et al. 2010; cf. Förster, this volume).

The present article presents not only a preliminary publication of the pottery from different peri-

ods, but also endeavours to show how pottery from the very particular circumstances of the Abu Ballas Trail sites contributes to both chronological and functional understanding of archaeological sites along an ancient desert road.

The size of the known sites differs greatly, ranging from fragments of a single jar up to more than a hundred vessels in different states of preservation. Some of the jars had been well protected against the wind and are still very well preserved. The large majority, however, have been eroded to different degrees. The location and structure of the sites can also be very different. Usually the depots are found at the foot of, or near, one of the ubiquitous sandstone cones dotting the vast regions of this part of the Libyan Desert. However, some minor depots were even placed on top of hills. The investigation of the environmental context of the pottery ensembles is, however, not the primary interest of the present article because this can only be fully discussed by considering the results of the excavations at several sites, which falls beyond the scope of this contribution.¹

Generally, the sites can be considered closed contexts, and although a number of them have been disturbed in antiquity or more recently, they nevertheless offer possibilities which are hardly ever available for sites in the Nile Valley. Much of the pottery was found broken, and although wind erosion of the fractures often caused practical problems, it was nonetheless most rewarding to search for joins between sherds. Assessing the minimum number of vessels was also possible with far greater accuracy than is normally expected on excavations in Egypt. The main problem for minimum vessel counts is that at sites where the pottery was not protected against the wind, extreme erosion may have caused the complete disintegration of vessels. Particularly for the New Kingdom sites, large storage jars were frequently found reduced to small sherds, and their complete disappearance seemed only a matter of time. Despite this issue, ceramic ensembles from the Abu Ballas Trail offer great research possibilities.

In the following pages, the individual sites are referenced following the 'Cologne registration sys-

1 The excavation of the three major sites Abu Ballas 85/55 (Abu Ballas/'Pottery Hill'), Jaqub 99/31 & 99/32 ('Muhattah Jaqub' as labelled by C. Bergmann) and Jaqub 99/30 ('Muhattah Umm el-Alamat') is presented in an unpublished MA thesis (Schönfeld

tem', which consists of three elements: (1) the name of the study area [cf. **Tab. 1**]; (2) the year of recording; and (3) the serial number of the individual site. "Jaqub 99/31", for instance, is the 31st site registered in 1999 within the study area "Jaqub". Individual vessels or sherds are referred to by their identity number, added to the former data in brackets, e.g., "Jaqub 99/31 (2)".

2. Sheikh Muftah culture

Pottery of the pastoral nomads of the so-called Sheikh Muftah culture was found at several sites of the Abu Ballas Trail, sometimes in combination with late Old Kingdom/First Intermediate Period pottery [**Tab. 1**]. Sheikh Muftah sites are concentrated at the oases of Dakhla and Kharga (Hope 1999; 2002; 2007; McDonald 1999; 2002; Warfe 2006; Riemer 2011), and it therefore seems logical to consider the Sheikh Muftah pottery along the Abu Ballas Trail as part of the late Old Kingdom/First Intermediate Period ensemble. It is indeed accepted that local population groups co-existed with the Egyptians after they had occupied the oases of the Western Desert (cf. Mills 1999), at the very latest from the 4th dynasty onwards. Recently, however, a Sheikh Muftah sherd was found on the eastern margins of the Great Sand Sea, suggesting that the activities of these pastoral nomads extended far beyond the immediate vicinity of the oases (Riemer 2009). Even before that, the wide distribution of so-called Clayton rings and discs, a most characteristic element for the Sheikh Muftah culture, was noted (Riemer & Kuper 2000; Riemer 2002; 2004; cf. Riemer 2011: 277–288; Riemer, this volume). Therefore, the possibility exists that the Sheikh Muftah presence at Abu Ballas Trail sites has to be seen separately from the 'official' Egyptian activities. This is rather obvious for the sites close to Dakhla, but could also be the case for the more distant sites. To some extent, this is confirmed by the Clayton rings and discs among the Sheikh Muftah finds. Clayton rings and discs hardly ever occur in association with late Old Kingdom/First Intermediate Period pottery if both are found at the same site. Most

2004). For an overview of the main results of the ACACIA excavations at sites along the Abu Ballas Trail, see Förster 2011: chapters 5–8.

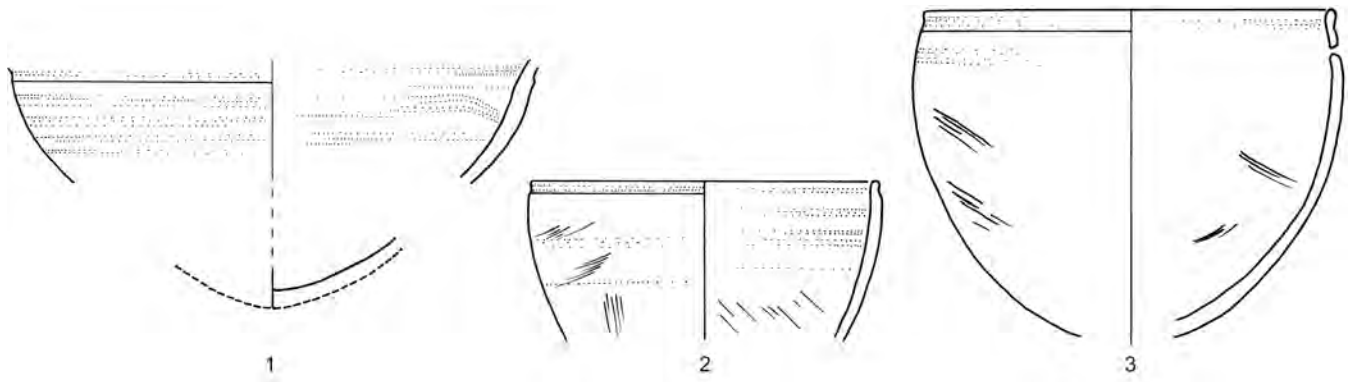

Fig. 2 Pottery of the Sheikh Muftah culture: 1 Shale tempered bowl, Jaqub 00/22 (W385, W394); 2 Imitation in shale tempered fabric of deep Egyptian bowl, Base Camp 00/27 (3); 3 Imitation in shale tempered fabric of deep Egyptian bowl, Meri 99/56 (W135). Scale 1:3.

probably many Clayton rings are part of desert exploitation by Sheikh Muftah people (cf. Riemer 2002; 2004; 2011; this volume), independent from the ‘official Egyptian’ Abu Ballas Trail (cf. *infra*).

Two fabrics occur among the Sheikh Muftah pottery. The first is a ‘shale’ tempered fabric, which is made from the same oasis clay as is used for the late Old Kingdom/First Intermediate Period pottery, but with a very large amount of coarse clay pellets (0.5–5 mm) added (cf. Riemer et al. 2005: 338; Riemer 2011: 50, fig. 14,16–17 “fabric EK 6A”). The second is also an oasis clay fabric, but the amount of sand in it is so high that it has to be considered a temper. This is confirmed by the angular shape of the sand (cf. Riemer et al. 2005: 338; Riemer 2011: 41, fig. 14,8 “fabric EK 3”).

Fire stains and the uneven surface colour of the vessels indicate that they were fired in a bonfire, which is characteristic for Sheikh Muftah pottery. The vessel types are mainly large deep bowls [Fig. 2,1], and the pottery technology (open fire) of both fabrics also differs strongly from the fabric used by the Egyptian potters in the Dakhla Oasis (Soukiassian et al. 1990: 77–84). A few vessels should be considered imitations of Egyptian types [Fig. 2,2–3] and testify the interrelation between the local pop-

ulation and the Egyptian occupants.² It comes as no surprise that these particular vessels are found in association with late Old Kingdom/First Intermediate Period pottery and at sites far away from the Dakhla Oasis (e.g., Base Camp 00/27).

Tab. 1 (opposite) Overview of the pottery from the Abu Ballas Trail: Minimum numbers of vessel units attested at individual sites.

The sites are arranged according to their distance from Balat/Dakhla, where the trail apparently had its departure point in the late Old Kingdom/First Intermediate Period. Some pottery-bearing sites situated in study area ‘Dakhla’ (Dakhla 00/12, 00/13, 00/14, 00/15; up to 40 km from Balat [cf. Fig. 1]) are not included here, since their possible relation to the Abu Ballas Trail is, as yet, unclear. At least part of these sites, which have so far only been surveyed, probably belong to the group of so-called hilltop sites in the outskirts of Dakhla, which had been used at various times to control the access points into the oasis (cf. Kaper & Willems 2002; Riemer et al. 2005; Förster 2010).

In terms of terminology, the typology of the late Old Kingdom/First Intermediate Period pottery as well as the early New Kingdom pottery largely follows classifications established by the IFAO missions working in Balat (Soukiassian et al. 1990; 2002) and Hope (1989), respectively (for details, see text).

In the given totals, so-called Clayton rings and discs have been counted as separate items, although some of them might have belonged together, making up individual ensembles typically consisting of one ring and one disc each (cf. Riemer & Kuper 2000).

Symbols added to site numbers:

- * larger part of ceramics still in situ (usually ≤ 10 vessel units)
- ** almost all ceramics still in situ (≥ 40 vessel units)
- ‡ (partly) excavated site
- ? vessel type or chronological affiliation uncertain
- \geq estimated minimum number of vessels

² Cf., however, Hope (2002: 40; 51) who argues that “[...] amongst the ceramic bodies utilised by the occupants of the oasis in the Old Kingdom there was also a coarse shale-tempered fabric and its makers were experienced potters [...]” and concludes “[...] it is possible that the use of shale wares on Egyptian sites was inspired by the Sheikh Muftah potters”. See also Hope 1999: 221 (“There is nothing to show that Egyptian ceramic traditions of the Old Kingdom influenced the local [...]”); 224; Soukiassian et al. 1990: 117–119, pls. 37; 38.

STUDY AREA	Meri										Jaqub										Abu Ballas	Base Camp	El-Nahud	SUM				
	99/57	99/58	99/59	95/5	00/16	00/17	99/56	99/55	99/54	99/37	99/35	99/34	99/33	99/31	99/32	00/18	99/30	00/19	00/20	00/21					00/22	00/23	00/24	00/25
DISTANCE FROM BALAT, DAKHLA (km)	43	49	50	55	61	74	76	77	82	89	98	105	120	129	129	136	153	163	166	166	173	176	177	207	250	271	350	359
Sheikh Muftah culture																												
Clayton ring																												
Clayton disc																												
Large Clayton ring																												
Carinated bowl																												
Deep bowl																												
Bowl																												
Late Old Kingdom/First Intermed. Period																												
Large storage jar																												
Jar rebord simple																												
Small jar																												
Coupe Ia1																												
Coupe Ia2																												
Coupe Ib																												
Coupe carine 1c																												
Restricted bowl																												
Spouted bowl																												
Vat																												
Second Intermediate Period																												
Small jar																												
Restricted bowl																												
Spouted bowl																												
New Kingdom, 18th dynasty																												
Amphora vertical handles, Ia, trunc. base																												
Amphora vertical handles, Ia, ring base																												
Amphora horizontal handles, Ib, ring base																												
Amphora 4 vertical handles, Ia, ring base																												
Storage jar, angular																												
Storage jar, rounded profile																												
Small jar																												
Late New Kingdom (19th/20th dynasty)																												
Jar																												
Jar broad																												
Jar very broad																												
Small cup																												
Small plate																												
Spouted bowl																												
Roman																												
Small jar with handles?																												
Small jar?																												
Quilla																												
Keg / jar?																												
Keg																												
Restricted bowl																												
Islamic																												
Mat decorated																												
Unknown																												
SUM	7	11	8	10	6	17	3	6	1	6	40	243	96	-79	10	1	79	1	4	5	11	8	28	241	3	243	11	220

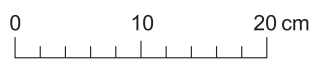
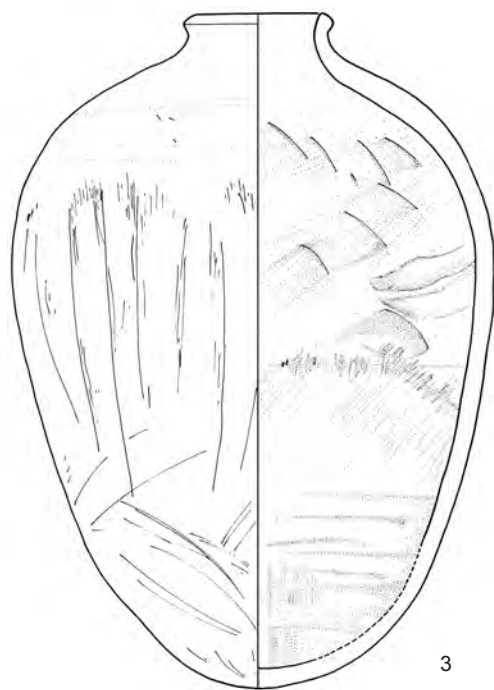
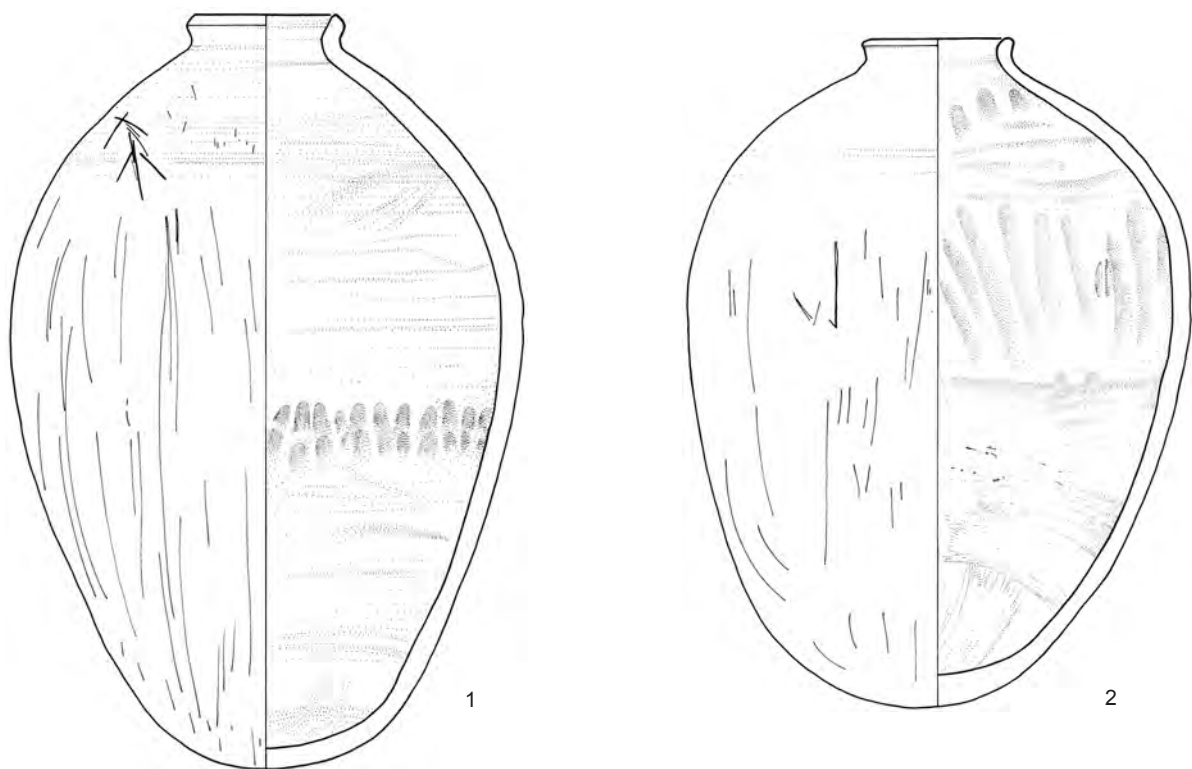
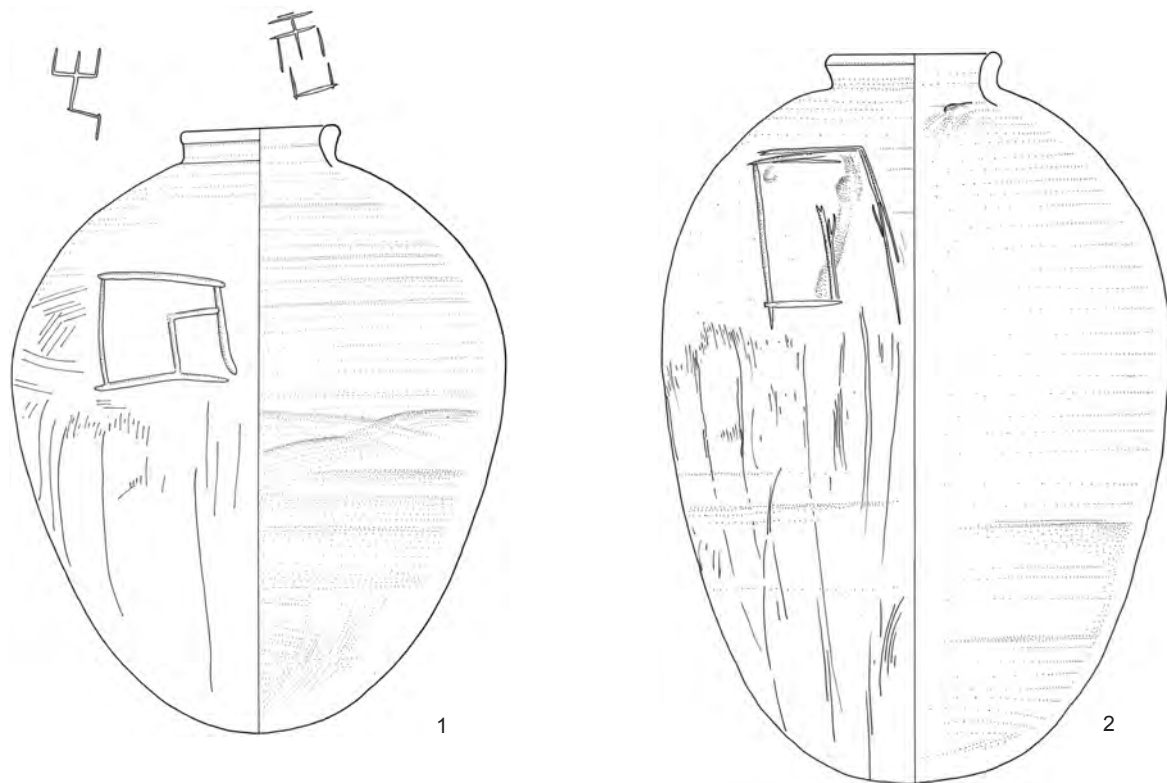

Fig. 3 Storage jars, late Old Kingdom/First Intermediate Period: 1 Abu Ballas 85/55 (5); 2 Abu Ballas 85/55 (10); 3 Abu Ballas 85/55 (11). Scale 1:6.

3. Late Old Kingdom/First Intermediate Period

The majority of the pottery found at the Abu Ballas Trail sites dates to the very end of the Old Kingdom or the beginning of the First Intermediate Period (around 2200/2100 BC) [Tab. 1]. Nearly all of the pottery is made of the same fabric, consisting of the Cretaceous red clay of the oases (Soukiassian et al. 1990: 82f.). It contains a large amount of sand and limited quantities of limestone particles, the ratio of which can differ. Also characteristic, though not always present, are fine clay pellets (<0.5 mm), often referred to as 'shale', which are a natural part of the oasis clay. Occasionally, shiny, soft, black or red particles occur, and these have been identified as ferruginous oxides (Soukiassian et al. 1990: 104). An identical fabric is described for the pottery production at Balat/Ayn Asil: *groupe 1, céramique fine sans dégraissant ajouté* (Soukiassian et al. 1990: 75–84). The fabric is hard and dense, and fires pink to greenish-grey. The limestone particles have occasionally started to disintegrate. The same clay is also used with organic temper, and this fabric occurs in large quantities at settlement sites (e.g., Soukiassian et al. 1990: 113; 2002: 465–467) but is hardly present



at all among the pottery of the Abu Ballas Trail. In addition to the oasis production, a very limited number of imports from the Nile Valley have also been found at Abu Ballas Trail sites. Both the Nile silt fabric (Nile B1 and Nile B2; Nordström & Bourriau 1993: 171f.) as well as the marl fabric (Marl A1; Nordström & Bourriau 1993: 176) are present.

For the current discussion, the sites at which the largest amounts of pottery were found will be used as type sites, Abu Ballas 85/55 (the original Abu Ballas or 'Pottery Hill' site) and Jaqub 99/31. For both sites, only three general types of pottery are represented. These are large storage jars [Figs. 3; 4], cups/bowls [Fig. 5], and straw tempered vats [Fig. 6]. Additionally, a single spouted bowl comes from site Jaqub 99/35 [Fig. 7]. The storage jars, measuring c. 45–65 cm in height, generally do not contain any substance (except for some remains of barley grain in a jar found at site Jaqub 00/20; see Förster, this volume: fig. 11). Furthermore, they sometimes show mineral stains characteristic of water evaporation. In a desert context, it is not surprising that they are water jars, nor that they are by far the most numerous vessel type at all Abu Ballas Trail sites. The jars are red-slipped and most of them seem to have been polished, although the surface of the ves-

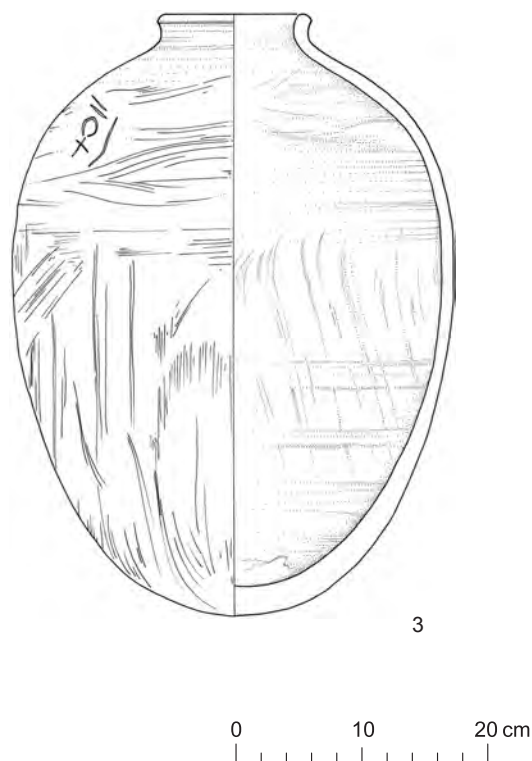

Fig. 4 Storage jars, late Old Kingdom/First Intermediate Period: 1 Jaqub 99/31 (2); 2 Jaqub 99/31 (986); 3 Jaqub 99/31 (961). Scale 1:6.

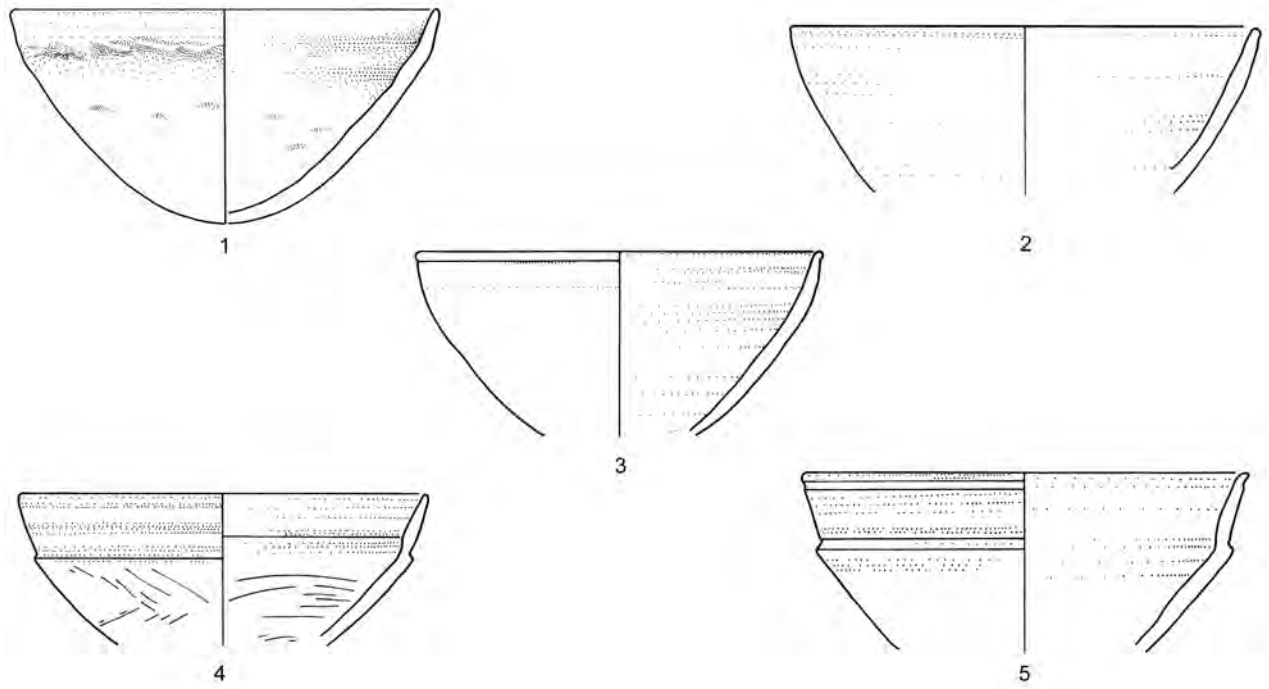

Fig. 5 Bowls, late Old Kingdom/First Intermediate Period:
 1–2 Bowls with convex wall, 1 Abu Ballas 85/55-32 (1); 2 Jaqub 99/31 (995);
 3 Bowl with convex wall and lip-rim, Abu Ballas 85/55-16 (25);
 4–5 Carinated bowls, 4 Abu Ballas 85/55-16 (1); 5 Jaqub 99/31 (51).
 Scale 1:3.

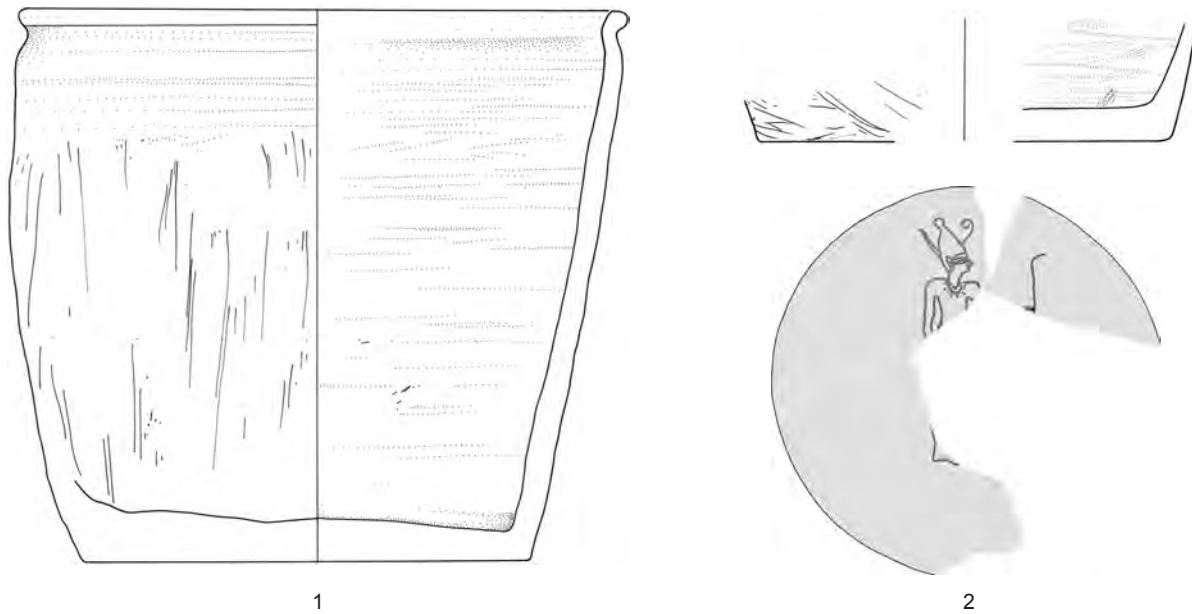
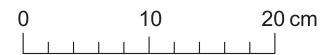

Fig. 6 Vats, late Old Kingdom/First Intermediate Period: 1 Jaqub 99/31 (3); 2 Abu Ballas 85/55-3 (1), (2), (W494) [cf. Fig. 9]. Scale 1:6.



sels is often so badly damaged by wind erosion that this cannot be confirmed beyond doubt. Slipping and polishing jars diminishes the porosity of the vessels, an essential quality for a desert environment.

Besides the large storage jars, both sites also have strongly resembling cups and bowls, as well as large, organic tempered vats. The former are generally heavily used and probably represent the personal 'tableware' of the expedition members. Occasionally, traces caused by fingers scraping the base of the bowls when eating can be seen [Fig. 8]. The presence of large vats [Fig. 6] is far more remarkable. Their importance is indicated by the considerable effort invested in taking these heavy and bulky objects along into the desert. The function of these vats for the preparation of bread dough is well known (cf. Faltings 1998: 115–121), and identical examples have been found in situ in the bakery of the governor's palace at Ayn Asil (Soukiassian et al. 2002: 205–209).

The vessel types illustrate the 'economic' activity on the Abu Ballas Trail, limited to the basics of water and bread. The spouted bowl [Fig. 7] facilitates pouring without spilling and of course reflects the importance of water on the Abu Ballas Trail. The absence of so-called Meidum bowls, one of the main archaeological characteristics of the Old Kingdom, should be noted. Although also tableware, these bowls seem to have been considered luxury products to some extent, and were not required in the desert.

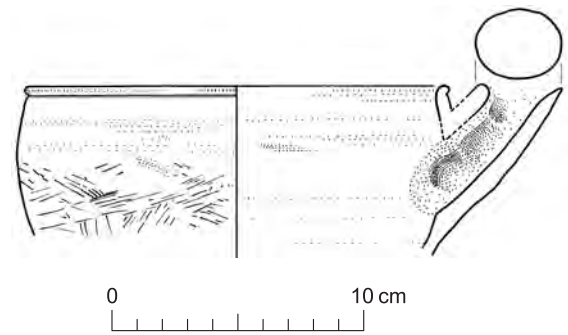

Fig. 7 Spouted bowl, late Old Kingdom/First Intermediate Period, Jaqub 99/35 (24). Scale 1:3.

The chronological position of the pottery from the Abu Ballas Trail is best considered through comparison with the extensive information available for the late Old Kingdom/First Intermediate Period at Balat/Ayn Asil (cf. Valloggia 1986; 1998; Minault-Gout 1992; Soukiassian et al. 1990; 2002; Castel et al. 2001; Castel & Pantalacci 2005). The average size of the Abu Ballas Trail storage jars (between 50 and 60 cm in height) exceeds that of the large jars from Ayn Asil (30–40 cm) (cf. Valloggia 1986: 150; Soukiassian et al. 1990: 107; 2002: 490, fig. 303 [934/1]; 498, fig. 320 [291/09]). Jars resembling those from the Abu Ballas Trail both in size and shape are known at Dakhla from the mastabas of the governors Ima-Pepi (Minault-Gout 1992: 167f.) and Khentika (Cas-

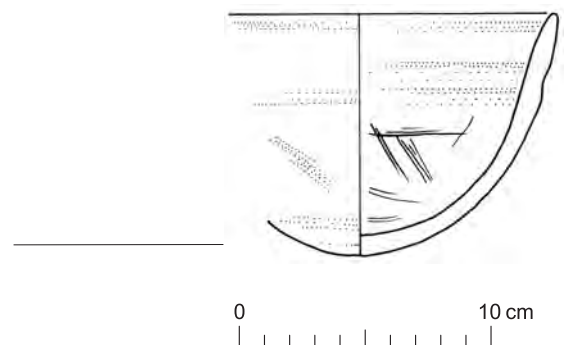

Fig. 8 Bowl with traces of use, late Old Kingdom/First Intermediate Period, Jaqub 00/22 (W400). Scale 1:3. Close-up of base sherd with traces of use (left). Scale c. 1:1.

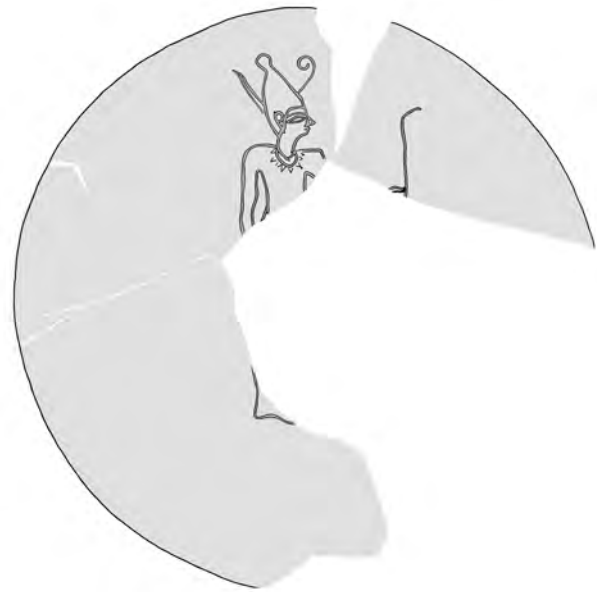

Fig. 9 Incised representation of a king on the exterior of the base of a vat [cf. Fig. 6,2], late Old Kingdom/First Intermediate Period, Abu Ballas 85/55-3 (1), (2), (W494). Scale 1:4.



tel 2001: figs. 145–152) and also from the cemeteries next to the mastaba of Khentika (Castel & Pantalacci 2005: 541f. [C66–C67]; 551 [C137–C138]). However, dating the storage jars precisely within the late Old Kingdom or First Intermediate Period remains problematic because of their limited typological evolution over time. Despite their restricted number, the cups and bowls offer better dating possibilities. The cups/bowls named à *carène basse* [Fig. 5,4–5] are particularly informative. They are a very characteristic product of the Ayn Asil ateliers, and although they probably originate at the end of the Old Kingdom, they are mainly dated to the First Intermediate Period (Soukiassian et al. 1990: 145).³ The *carène basse* cups/bowls are not represented in the mastabas of Ima-Pepi (cf. Minault-Gout 1992) and Medu-Nefer (cf. Valloggia 1986) which date respectively to the second half of the reign of Pepi I/beginning of the reign of Pepi II, and the second third of the reign of Pepi II. The broad convex cups/bowls [Fig. 5,1–2] also point towards the First Intermediate Period (Soukiassian et al. 1990: 144),⁴ which is less obvious for the cups/bowls of the same shape but with lip-rim [Fig. 5,3] (Soukiassian et al. 1990: 145).⁵ For the spouted bowl from site Jaqub 99/35 [Fig. 7], very close parallels are known from

the governor's palace at Ayn Asil (Soukiassian et al. 2002: 478, fig. 279 [1152/9; 1304/04]).⁶ Finally, the large straw tempered vats [Fig. 6] confirm the late Old Kingdom/First Intermediate Period date (cf. Soukiassian et al. 1990: 112f.).⁷ When compared to the pottery from the palace of the governors at Ayn Asil, there are important similarities to the pottery dated at Ayn Asil to the *première phase post-incendie*, which corresponds to the end of the Old Kingdom or the beginning of the First Intermediate Period

3 See also Soukiassian et al. 1990: 95 (*coupes à carène basse, groupe 1c*), pl. 18, nos. 20–21; Castel et al. 2001: fig. 137, C98–99; Soukiassian et al. 2002: 479, fig. 280.

4 See also Soukiassian et al. 1990: 93 (*coupes convexes évasées, groupe 1a1*), pl. 15, nos. 1,3–5; Soukiassian et al. 2002: 471f., figs. 271; 272.

5 See also Soukiassian et al. 1990: 95 (*coupes à incision externe sous le rebord, groupe 1b*), pl. 17, no. 15; Castel et al. 2001: fig. 138, C120; Soukiassian et al. 2002: 477, fig. 278 (1304/22).

6 See also Arnold 1982: pl. 10b; Hope 1979: pl. XX,4.

7 See also Soukiassian et al. 1990: 112 (*bassines à dégraissant végétal*), pl. 33; Castel et al. 2001: fig. 135, C78; Soukiassian et al. 2002: 503, fig. 335 (1228/1).



Fig. 10 Photograph taken by L. Almásy in spring 1933 showing the remains of the late Old Kingdom/First Intermediate Period pottery deposit at Abu Ballas (1). On some of the storage jars in the foreground, damage caused by wind-blown sand is clearly visible (Almásy 1934: 3rd figure after p. 120). Wind erosion lines or even sandblasted holes have also been observed on many jars found at other sites along the Abu Ballas Trail, such as on the jars excavated at Jaqub 99/31 (2).



(Soukiassian et al. 2002: 9–12; 521–523, figs. 1; 5; cf. Soukiassian 1997; Jeuthe 2012: 14; 22; 459).

Potmarks occur frequently on the storage jars, incised both before and after firing [cf. **Figs. 3; 4**]. It is of great importance to note that the same potmarks occur on jars from both sites, indicating that they had a common origin. The most frequent sign is the hieroglyph  [cf. **Fig. 4,2**], a potmark that is also attested at the late Old Kingdom/First Intermediate Period site of Ayn Asil in Dakhla, more precisely at the governor's palace (Soukiassian et al. 2002: 456–459, figs. 269 [592b; 1389]; 270 [647e]). The hieroglyph can be read as *h* or as an abbreviation of *wshyt*, both words meaning 'hall, courtyard' (cf. Hannig 2003: 383; 741). It therefore may refer to the palace itself, meaning that the potters indicated the destination or ownership of the vessels.

The two sites, Abu Ballas 85/55 and Jaqub 99/31, are not only contemporaneous but should also be considered elements of the same operation. Because of the above mentioned very close parallels between the pottery from the sites Abu Ballas 85/55 and Jaqub 99/31, and that from Ayn Asil, it has to be accepted that all of this pottery was produced at Ayn Asil, at the well-known pottery workshops of that site (Soukiassian et al. 1990). On the fragmentary

base of a vat from site Abu Ballas 85/55, a carefully drawn representation of a king was found [**Fig. 9**],⁸ which also points to the 'official' character of the pottery production. It can hardly be doubted that the complex logistics and important investment of means behind the desert expeditions indicate that the initiative for these activities came from the reigning governor of the oasis (cf. Förster, this volume).

Wind erosion lines are visible on many storage jars [**Fig. 10**], indicating that the jars were lying with their axis at an angle between about 20° and 45°, aperture upwards. This clearly shows that all of the jars were empty when left behind. Accepting 30 litres as average capacity of the jars, site Abu Ballas 85/55 (originally with at least 100 jars, perhaps as many as 200, cf. Jarvis 1936: 115f.) may have represented a water supply of 3000–6000 litres, and site Jaqub 99/31 (min. 58 jars) of at least 1740 litres. The jars themselves weigh 14–15 kg on average, and when filled with water their weight would have been around 45 kg. This is not easy to handle, and

⁸ The fragments were found among the mass of sherds turned over by present day visitors to the site. Cf. Förster, this volume: fig. 24.

the risk of breaking jars during transport seems rather high. The water, therefore, must have been carried in much lighter and less vulnerable water bags made of goat skins (cf. Förster, this volume). Carrying the water in skins was a necessity anyway, because it would have been totally ineffective to carry the heavy jars up and down the Abu Ballas Trail. Rather, they would have been installed as depots, and repeatedly refilled.

The transport of water in water bags and not in the storage jars themselves is to some extent confirmed by the fact that nothing has been found that could have been used for sealing the jars during transport. Clay stoppers, as used in the Nile Valley, are of course out of question because they would imply spilling water needed to mix with the clay. The cups and bowls are far too few in number to have been used for closing the jars. Moreover, their deep shapes would have been inappropriate, and cups or bowls for closing jars are normally used in combination with clay caps, which was not possible in the desert environment because, again, it would imply spilling water. Once the jars were filled at the individual supply stations, it seems that perishable material such as leather was used for closing the vessels, but this is not a secure method for closing water jars during transport.

The three most important late Old Kingdom/First Intermediate Period sites are Jaqub 99/31 (together with site Jaqub 99/32, situated close by), Abu Ballas 85/55, and Base Camp 00/27. Considering the large amount of storage jars, animals must have been watered at these sites and probably also at El-Nahud 00/7, not far from the Gilf Kebir. The distances between these main supply stations are roughly equal (64–88 km as the crow flies) and correspond to a two or three day journey for a donkey caravan (cf. *infra*, section 8). Vats and different types of cups and bowls have been found at the first two sites only, but this might be explained by the fact that Base Camp 00/27 and El-Nahud 00/7 have hardly been investigated. Intermittent sites used as camp sites and/or minor supply stations – but not, or only to a limited extent, for watering animals – are represented by Meri 00/17 and Jaqub 99/35 (between Dakhla and Jaqub 99/31), Jaqub 99/30 and Jaqub 00/24 (and/or Abu Ballas 00/25?; cf. Bergmann 2001: 425) and perhaps also Jaqub 00/22 (between Jaqub 99/31 and Abu Ballas 85/55) and eventually Abu Ballas 00/26 (between Abu Ballas 85/55 and

Base Camp 00/27) [cf. **Tab. 1**]. Vats have not been found at the latter sites. All of the remaining sites consist of only a single or a few jars. They may represent small-scale storage but in some cases may simply consist of broken jars left on the way.

A number of relatively small, globular jars deserve a separate note. They have been found at several sites [cf. **Tab. 1**], but a well preserved group of them is only available from site Jaqub 99/35. For all of the sites where these jars have been found, large storage jars are also present. However, parallels for the smaller jars are rare in the late Old Kingdom/First Intermediate Period pottery from Ayn Asil (Soukiassian et al. 1990: pl. 29, no. 88; pl. 43, no. 182). The possibility of a late First Intermediate Period or early Middle Kingdom age was considered in view of the recent but unexpected discovery at Jebel Ouenat of a rock inscription of Mentuhotep II (Clayton et al. 2008; cf. Förster, this volume: figs. 40; 41; Pantalacci, this volume: fig. 7). Additionally, a few jars tend to become drop-shaped [**Fig. 11,1**], which is an important characteristic of Middle Kingdom pottery. Among these jars globular shapes are also found [**Fig. 11,2**], and late First Intermediate Period and early Middle Kingdom parallels are rare. At first sight there is a resemblance to globular jars from el-Tarif (Seidlmayer 1990: 83, fig. 31), but these are smaller and have more pronounced necks and rims. Comparison can also be made with globular jars from Dendera (Seidlmayer 1990: 116, fig. 42.189,40; 119, fig. 44 top right), which are similar in size to those from site Jaqub 99/35 but again differ in neck and rim. Still for Dendera, First Intermediate Period – 11th dynasty cooking vessels (Marchand 2004: figs. 60–62) show some resemblance, but these jars are not only smaller but also made in an entirely different technique as shown by the clearly visible turning traces on their interior. Finally, related jars are known from the Qau-Matmar region (Seidlmayer 1990: 156, fig. 62 K-B21.01; 160, fig. 64 K-B31.05) but, as is also the case for several of the already mentioned ‘parallels’, they can date to the end of the Old Kingdom or the (early) First Intermediate Period as well.⁹ Furthermore, the jars from site Jaqub 99/35 are made of the same oasis fabric and according to the same technique as the large jars. For all of these reasons, and especially because there is no archaeological indication to separate this group of vessels from the late Old Kingdom/early First Intermediate Period pottery, it

Fig. 11 Small storage jars, late Old Kingdom/First Intermediate Period: 1 Jaqub 99/35 (14); 2 Jaqub 99/35 (5). Scale 1:6.

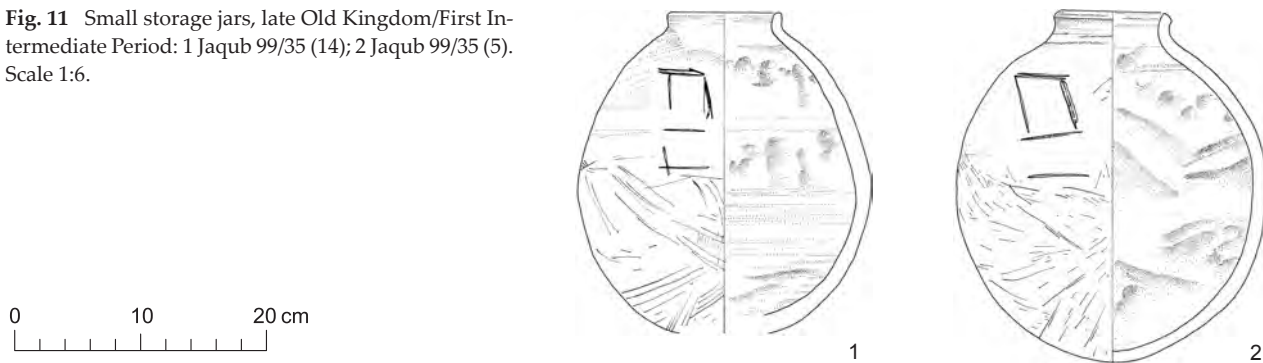

should be accepted that late First Intermediate Period or early Middle Kingdom pottery has not been found on the sites of the Abu Ballas Trail. The difference between the pottery assemblages at sites Abu Ballas 85/55 and Jaqub 99/31 (and others), on the one hand, and at Jaqub 99/35, on the other hand, should be considered functional and not chronological, meaning that Jaqub 99/35 was not a real staging post but rather a camp site.

The absence of late First Intermediate Period/early Middle Kingdom pottery along the trail makes the Mentuhotep II inscription at Jebel Ouenat all the more enigmatic and even raises the question whether it is related to the Abu Ballas Trail. Nevertheless, it might be conceivable that the (rather small?) expedition party that left the inscription behind had re-used some of the old pottery deposits of late Old Kingdom/early First Intermediate Period times – or single jars that remained intact – to get there. This would imply that the latter were still known and, at least in part, still usable in the early reign of Mentuhotep II (cf. Förster, this volume). Recently, a radiocarbon date was obtained from a sample of barley remains found in one of a group of four late Old Kingdom/early First Intermediate Period storage jars that have been excavated at site Jaqub 00/20 (3520 ± 35 BP / 1845 ± 55 calBC; Poz-23221). This date, pointing to activities during the 12th dynasty, proves that, at least in this

case, a few old jars were indeed re-used in much later times. Except for a semi-hieratic rock inscription found comparatively close to Dakhla at site Meri 95/5 (cf. Burkard 1997; Förster, this volume: fig. 39), this finding however is the only evidence so far which attests to Middle Kingdom activities along the trail.

4. Second Intermediate Period

Only a very small number of vessels can be attributed to the Second Intermediate Period (c. 1800–1550 BC, cf. von Beckerath 1997: 189), and there are no large storage jars comparable in size to the late Old Kingdom/First Intermediate Period jars among them. The identification of the vessels as of Second Intermediate Period date can not, however, be doubted, both on typological and technological grounds. All of the vessels are made from the untempered oasis fabric already in use during the late Old Kingdom/First Intermediate Period. The types are limited to relatively small jars [Fig. 12], a spouted bowl [Fig. 13,1], and a restricted bowl [Fig. 13,2]. On their inside, they show clear traces of very regular slow turning. The upper part of the outer surface is horizontally smoothed, while the lower part is scraped/brushed to remove excess clay after shaping the vessels. Parallels for the spouted bowl [Fig. 13,1] are known from Dakhla (Hope 1980: pl. XX,j, XXI,d; 1983: fig. 2,k–l; Ballet 1990: 24, no. 17), and although its shape is almost identical to that of the late Old Kingdom/First Intermediate Period [cf. Fig. 7], the difference in fabrication technique demonstrates the chronological difference.¹⁰ Scrap-

9 See the relevant *Stufen* attributed by Seidlmayer (1990: 395, fig. 168) to the mentioned pottery types and their chronological position.

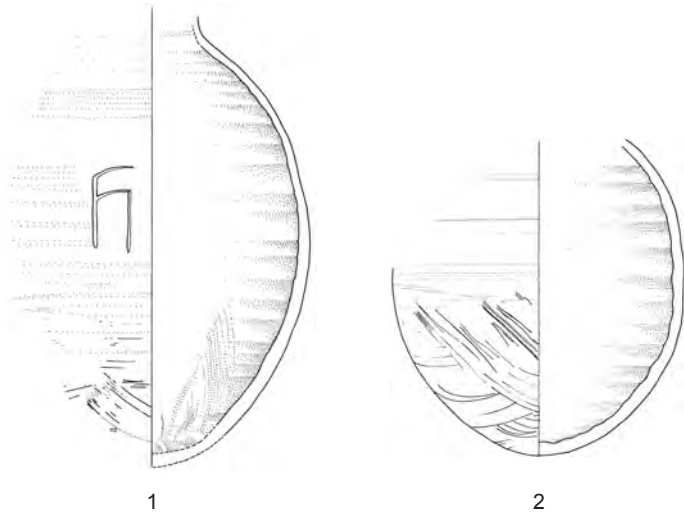

Fig. 12 Jars, Second Intermediate Period: 1 Jaqub 99/32 (1616); 2 Jaqub 99/35 (25). Scale 1:6.

ing of the lower part of jars is well attested at Ayn Asil for the Second Intermediate Period (cf. Marchand & Soukiassian 2010: 174f.; 209–211). The restricted bowl or cup [Fig. 13,2] is to some extent comparable to a cup with perforations below the rim (Ballet 1990: 21, no. 9), although the example from site Meri 99/37 is much broader and the perforations are lacking.¹¹ Comparison to Second Intermediate Period slow turned cups with scraped base is also possible (Marchand & Soukiassian 2010: 180f.). The bad preservation of the jars [Fig. 12] hinders identification of exact parallels, but parallels

should be present among jars found at Dakhla (cf. Hope 1980: pl. XXb, XXIIj; 1983: fig. 2,a/d; 1999: 228, fig. 19; Ballet 1990: 23, nos. 15; 16).

The rarity of Second Intermediate Period pottery on the Abu Ballas Trail, attested as individual pieces at four sites only [cf. Tab. 1], and especially the absence of large storage jars, makes it doubtful that large-scale operations took place at that time. Furthermore, the Second Intermediate Period vessels were not found in archaeological relation with pottery from other periods, although late Old Kingdom/First Intermediate Period pottery was also found on each of the sites. In this respect it is important to notice that none of the vessels have been found beyond a distance of c. 130 km from Balat/Dakhla, and the Second Intermediate Period activity may have been limited to small-scale operations, for example hunting parties or desert patrols (cf. Förster, this volume).

10 See also the Second Intermediate Period spouted bowls from Ayn Asil made in the same manner but with rounded base (Marchand & Soukiassian 2010: 190f.).

11 For a possible parallel from Tell el-Dab'a, dating to the 13th dynasty, see Müller 2008: 329f., fig. 191 (K 2205-1).

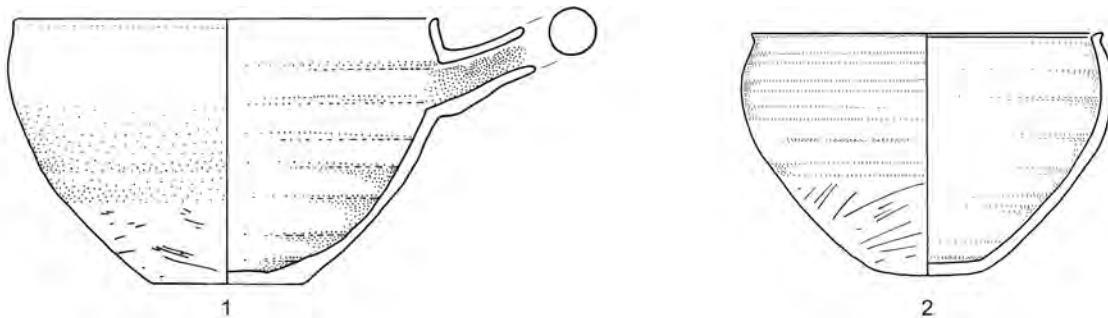

Fig. 13 Bowls, Second Intermediate Period: 1 Spouted bowl, Jaqub 99/31-1 (1402); 2 Restricted bowl, Meri 99/37 (5). Scale 1:3.

5. New Kingdom, 18th dynasty

Vessels from the 18th dynasty occur at several sites along the trail and up to 350 km from Balat/Dakhla [cf. **Tab. 1**]. However, a large number of vessels are attested for only two sites, Jaqub 99/34 and Abu Ballas 00/25 (min. 40 at each). Neither of them has been excavated yet and the pottery was only examined on site, limiting the possibilities for typological study. This perhaps also accounts for the complete absence of cups, bowls and spouted vessels. Furthermore, site El-Nahud 00/6, the only one for which all available pottery was studied, was probably not found in its original position (but may well have constituted another main supply station in those times) [**Fig. 14**].

The fabric is very similar to the late Old Kingdom/First Intermediate Period untempered oasis fabric. This fabric seems identical to fabric B23, identified by Ecclestone (2002) for New Kingdom pottery at Dakhla. All of the jars are slowly turned, starting from a pushed-out base. They were probably moulded, but this can not be confirmed beyond doubt because of the heavy wind erosion on most bases. Vertical finger strokes are always visible on the interior of the base, and the walls of the base are very thick and heavy. On the inside, the turning marks have not been worked over, while on the outside they remain visible but have been partially smoothed.

Among the material studied, storage jars with and without handles can be distinguished, the first group called ‘amphorae’, following Hope (1989; cf. Hope et al. 2002). The shape variation is important, and considering the limited amount of vessels available, the types distinguished are represented by a few examples only, or even by a single one. The highly eroded state of the vessels sometimes makes it impossible to know whether or not handles were present, and for the same reason the shape of the base can be beyond recognition. Amphorae with two vertical handles occur with rounded/truncated base [**Fig. 15**], and with ring base [**Fig. 16**]. For the former, parallels are known from Dakhla (Hope 1989: 102; figs. 1,7; 2,1; Hope et al. 2002: 97f.; 119f.; Marchand & Tallet 1999: 341, figs. 12a; 13a–b [?]), while for the latter no complete examples have yet been found, but the base type with ring is attested at Dakhla (Hope et al. 2002: 120, fig. 3m). A single, well preserved amphora with four vertical handles



Fig. 14 El-Nahud 00/6: Storage jars found at a small rock outcrop may well have been part of a main supply station established and used during 18th dynasty times.

[**Fig. 17**] has no parallel at Dakhla, but similar vessels are known elsewhere from the time of Amenhotep III (Hope 1989: fig. 4.4) and Akhenaten (Frankfort & Pendlebury 1933: pl. LIII; fig. XVII.9). Vessels with horizontal loop handles occur, but none of them are well preserved [**Fig. 18**]. This type of handles also occurs in Dakhla (Marchand & Tallet 1999: fig. 12b). Both for the Abu Ballas Trail sites and for Dakhla, horizontal handles are far less numerous than vertical ones (Marchand & Tallet 1999: 327).

For the storage jars without handles, at least two types are represented, one with rounded profile [**Fig. 19**], the other with angular profile [**Fig. 20**]. No parallels for either of these are currently known from the Dakhla Oasis.

It is important to note that the characteristic *amphores à bouton* (cf. Marchand & Tallet 1999: 342, fig. 14) are lacking on the Abu Ballas Trail sites. The knobbed bases are obviously a simplified version of the ring bases known from the Abu Ballas Trail and therefore probably a more recent development. The *amphores à bouton* are considered characteristic for the end of the 18th dynasty by Marchand & Tallet (1999: 319; 328). However, the *amphores à bouton* could also occur during the 19th–20th dynasties, i.e. the Ramesside Period, but the arguments given by Aston and accepted by Hope et al. (2002: 98) remain inconclusive.

According to the amphorae typology established by Hope, particularly good parallels for the amphorae with two vertical handles and

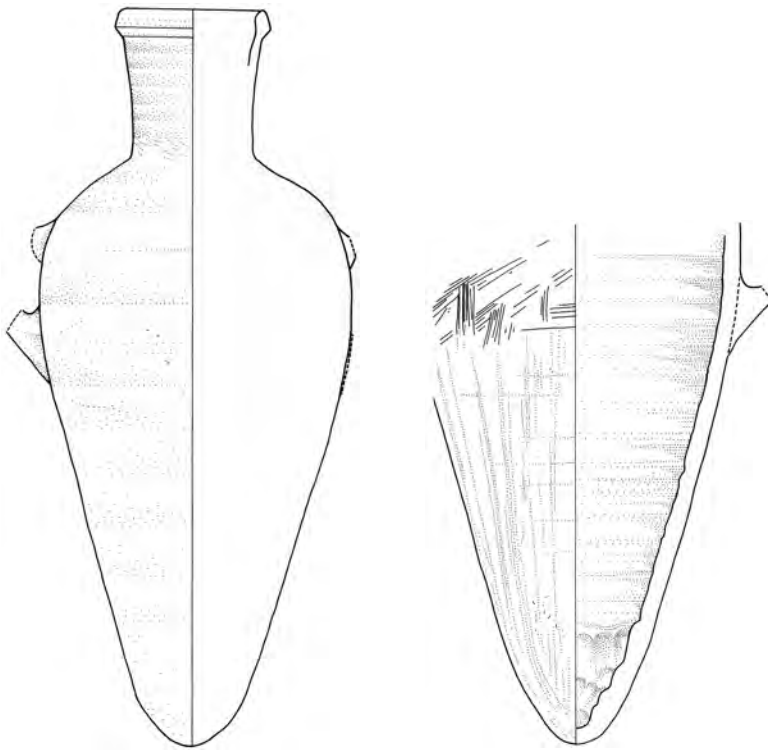

0 10 20 cm

Fig. 15 Amphorae with two vertical handles and rounded/truncated base, New Kingdom, 18th dynasty: 1 El-Nahud 00/6 (32); 2 Jaqub 99/31 (442). Scale 1:6.

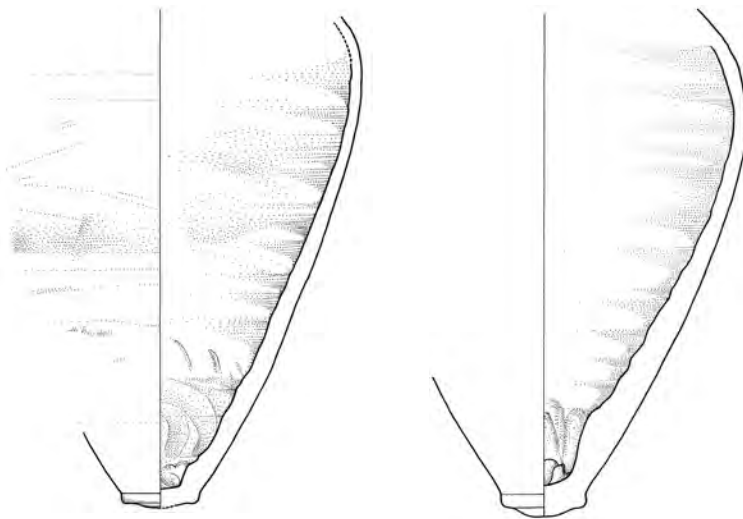

0 10 20 cm

Fig. 16 Amphorae with two vertical handles (not preserved in the shown examples) and ring base, New Kingdom, 18th dynasty: 1 El-Nahud 00/6 (19); 2 Abu Ballas 85/55 (2). Scale 1:6.

rounded/truncated base from El-Nahud 00/6 [Fig. 15] are found with jars dated to the time of Amenhotep II (Hope 1989: fig. 1.7) and Amenhotep III – Horemheb (Hope 1989: fig. 2.1). The late 18th dynasty amphorae tend to become more elongated and tapering compared to those from site El-Nahud 00/6 (Hope 1989: 93). Specifically for the Dakhla Oasis, the high, funnel shaped necks of the Abu Bal-

las Trail jars are not represented among the final 18th dynasty material from Ayn Asil published by Marchand & Tallet (1999). For all of these reasons, a date in the second half of the 18th dynasty (c. 1400–1300 BC, cf. von Beckerath 1997: 189f.) seems most likely.

Remarkably, better parallels for the jars from site El-Nahud 00/6 are found in the Nile Valley than

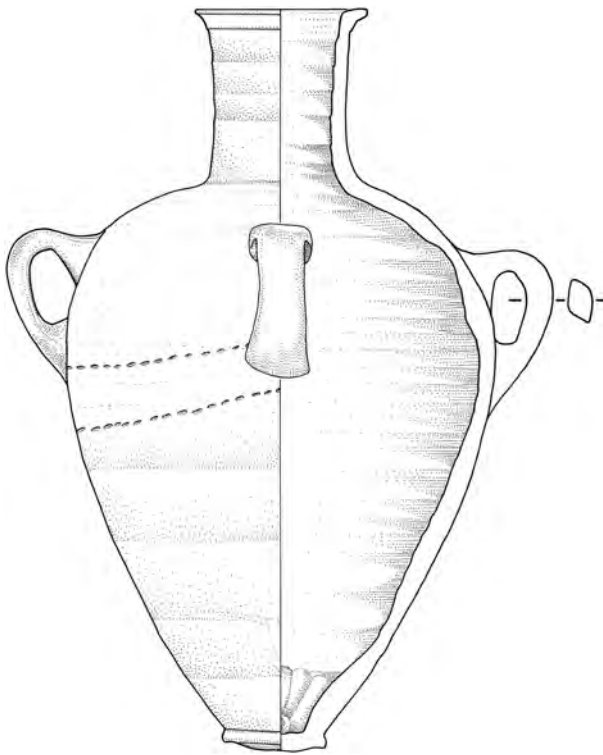

Fig. 17 Amphora with four vertical handles and ring base, New Kingdom, 18th dynasty. El-Nahud 00/6 (24). Scale 1:6.

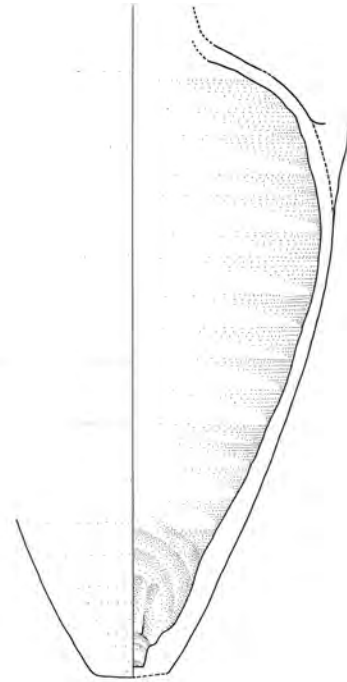
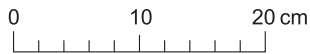

Fig. 18 Amphora with two horizontal handles, New Kingdom, 18th dynasty. El-Nahud 00/6 (20). Scale 1:6.

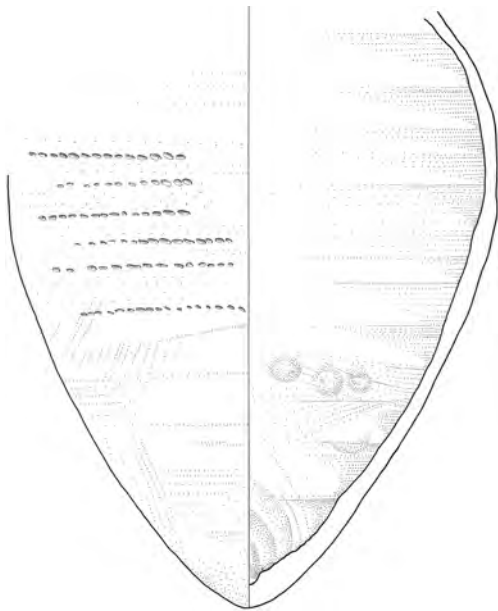

Fig. 19 Storage jar with rounded profile, New Kingdom, 18th dynasty. El-Nahud 00/6 (26). Scale 1:6.

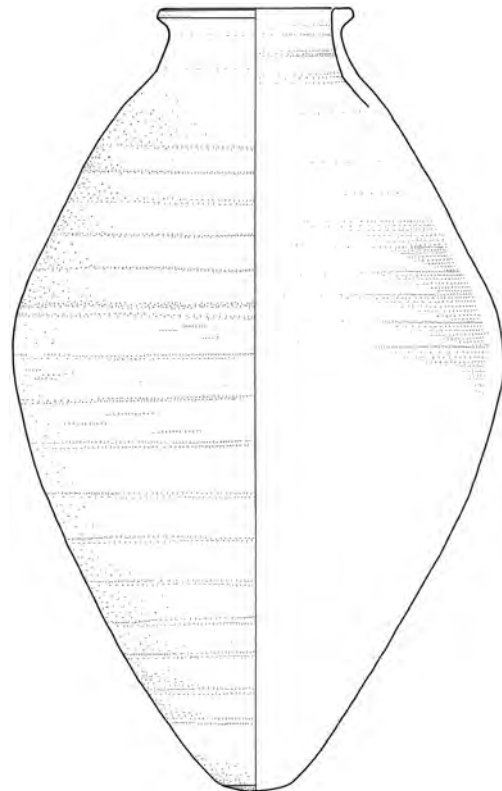

Fig. 20 Storage jar with angular profile, New Kingdom, 18th dynasty. El-Nahud 00/6 (25). Scale 1:6.

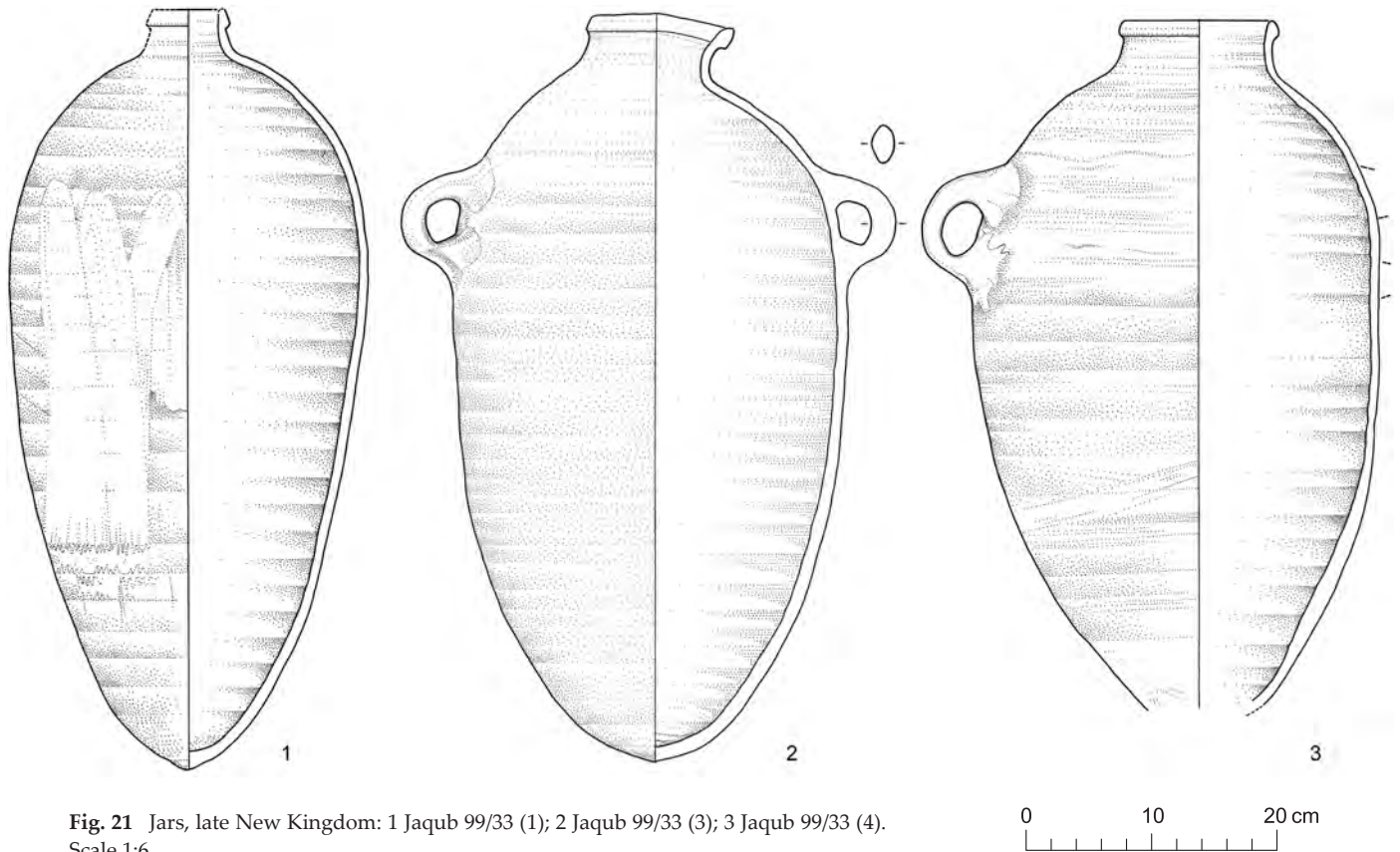

Fig. 21 Jars, late New Kingdom: 1 Jaqub 99/33 (1); 2 Jaqub 99/33 (3); 3 Jaqub 99/33 (4). Scale 1:6.

among the amphorae produced in the oases. The oasis jars found in dated contexts in the Nile Valley at Malkata (Hope et al. 2002: 123; 18th dynasty, Amenhotep III), el-Amarna (op.cit.: 128–130; 18th dynasty, Thutmose IV – Akhenaten), Theban Tomb 253 (op.cit.: 127, fig. 10a; 18th dynasty, Thutmose III–IV?) and Qantir (op.cit.: 121; 19th dynasty, Ramses I – Merenptah) show on the interior pushed-up traces of fingers up to nearly half of the height of the vessels. The vessel walls tend to remain very thick up to that height. This technique is not attested for the jars found at the Abu Ballas Trail sites. Furthermore, the shapes of the oasis jars just mentioned are more slender and the shoulder is less pronounced ('regularly curved' jars) compared to those from the Abu Ballas Trail. This might very well indicate a direct influence from the Nile Valley for the Abu Ballas Trail vessels.

There are three principal sites, or main supply stations, where animals were watered: Jaqub 99/34, Abu Ballas 00/25, and probably El-Nahud 00/6. In-

termittent sites used as camp sites and/or minor supply stations could be Meri 99/55 (between Dakhla and Jaqub 99/34), Jaqub 99/31 (between Jaqub 99/34 and Abu Ballas 00/25) and Abu Ballas 85/55 (between Abu Ballas 00/25 and El-Nahud 00/6). Another one may have been Base Camp 00/27 where only one 18th dynasty storage jar is currently attested, but this site has, as yet, hardly been investigated. Compared to the late Old Kingdom/First Intermediate Period, the first main supply station, site Jaqub 99/34, is located closer to Dakhla, which might imply a different starting-point in the oasis, perhaps at Mut el-Kharab or its surroundings [cf. Fig. 1].

6. Late New Kingdom (Ramesside Period)

Two sites, Jaqub 99/30 and Jaqub 99/33, yielded a large number of identical, slow-turned and thin-walled jars [Fig. 21]. Both sites have been excavated

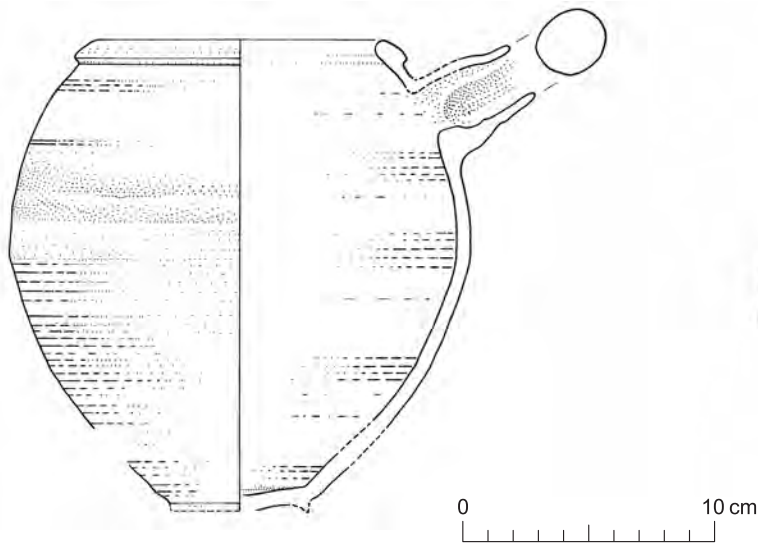

Fig. 22 Spouted vessel, late New Kingdom, Jaqub 99/33 (400–408; 442). Scale 1:3.

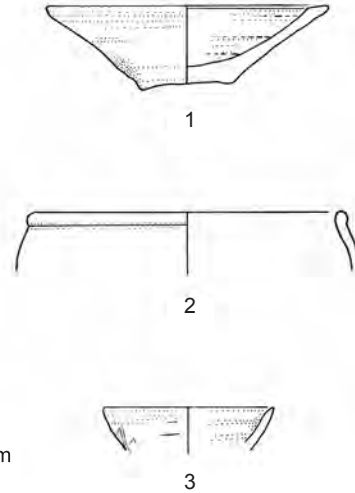

Fig. 23 Bowl, plate and cup, late New Kingdom: 1 Plate, Jaqub 99/30 (282); 2 Restricted bowl, Jaqub 99/30 (324); 3 Cup, Jaqub 99/30-1 (44/68a). Scale 1:3.

and all of the material found was studied. The state of preservation of the jars is very bad, especially for the necks and rims, and many vessels have been reduced to almost shapeless wall sherds, eroded from all sides.¹² All of the vessels are (again) made from the untempered oasis fabric, with limited presence of fine clay pellets (<0.5 mm). The same matrix also occurs with limited presence of (unidentified) grains, but these are probably incidental inclusions and need not be considered actual temper. Besides the jars, a spouted vessel [Fig. 22], a small plate [Fig. 23,1], and a fragmentary restricted bowl [Fig. 23,2] are the only other vessels made from oasis fabric. Furthermore, a single Marl A4 cup [Fig. 23,3] has

12 A difference in the wind erosion can be observed between the late Old Kingdom/First Intermediate Period jars and those from the late New Kingdom. The late Old Kingdom/First Intermediate Period jars were lying with their axis in an angle between about 20° and 45°, aperture upwards, while the late New Kingdom jars were generally lying horizontal or with their axis in an angle below 20°. This is apparently only a consequence of the difference in shape and of the very thick and heavy bases of the late Old Kingdom/First Intermediate Period jars which resist wind erosion better. It does however indicate that all of the jars were empty when left behind.

been identified and obviously represents an import from the Nile Valley. Contrary to the late Old Kingdom/First Intermediate Period sites Abu Ballas 85/55 and Jaqub 99/31, there are no vats or other vessels related to bread production at the late New Kingdom sites.

All of the jars are slow turned, and nearly all of the bases are turned as part of the lower section of the vessel rather than pinched or moulded. In a few cases, finger strokes are visible on the interior of the base, but these may be due to reworking of a turned base. The turning marks remain visible on the jars, both on the inside and outside. Occasionally, the outside is (partially) covered with a white wash. The jars show a particularly large number of deformations and were obviously made without much care [Fig. 24]. Despite this, all of them were functional. Furthermore, the jars show no traces of use such as damage on the rim, and seem to have been in mint condition when taken into the desert. Most likely they were made especially for this purpose.

Often potmarks, incised before firing, are present just above the base. These small marks were applied when the vessels were drying, standing upside down, and must relate to the organisation of the pottery workshop. The same type of potmarks has also been noted on pottery from Ayn Asil dating



Fig. 24 Remains of late New Kingdom jars exhibiting deformations: 1 Jaqub 99/33 (337); 2 Jaqub 99/33 (40); 3 Jaqub 99/33 (385). Scale c. 1:6.

to the end of the 18th dynasty (Marchand & Tallet 1999: 342, fig. 14).

The shape of the jars is rather uniform, certainly when compared to the 18th dynasty vessels already discussed. The jars are ovoid to oval in shape, generally with small vertical handles. They have pointed bases, low necks, and a narrow aperture, and are related to *amphores à col court type A1* (Marchand & Tallet 1999: 330, fig. 8), which date to the end of the 18th dynasty. However, the necks of these *amphores à col court type A1* are generally longer, the aperture wider and the handles larger. There are no good parallels from the Nile Valley,¹³ although the small vertical handles are characteris-

tic for the Ramesside Period (cf. Bavay et al. 2000: 83). Furthermore, the size of the vessels for which the height is definitely known (56.5–60.3 cm, 4 examples) seems to exceed the size of similar vessels known from the Nile Valley. All of this confirms the impression that the vessels were specially made for, and adapted to, a desert expedition. Unfortunately, no parallels have been found for the spouted vessel [Fig. 22], while the few other vessels besides the jars are not sufficiently characteristic to allow dating.

From a typological point of view, what can be said at present is that the vessels most likely date to the late New Kingdom, i.e. the Ramesside Period (c. 1300–1070 BC, cf. von Beckerath 1997: 190). This is confirmed and substantiated by a radiocarbon date (2995 ± 37 BP / 1230 ± 70 calBC; UtC-8868) that has been obtained from a sample of the well preserved remains of a basket found at site Jaqub 99/33. The basket is directly linked to the pottery and therefore provides a most reliable chronological indicator. It was still covered with some vessels when found (cf. Förster, this volume: fig. 27), likely

13 Cf. Nagel 1938: passim; Holthoer 1977: pl. 17, 185/122:1; pl. 22 "ordinary amphorae Q/12"; Aston 1998: 499, no. 1956; 507, nos. 1994; 1995; Bavay et al. 2000; Holthoer 1993: 43–56, figs. L; M; Thomas 1981: pl. 7. Although not identical, the Nile silt Rameside amphorae from Qantir also seem related (cf. Aston 1998: 197, no. 584).

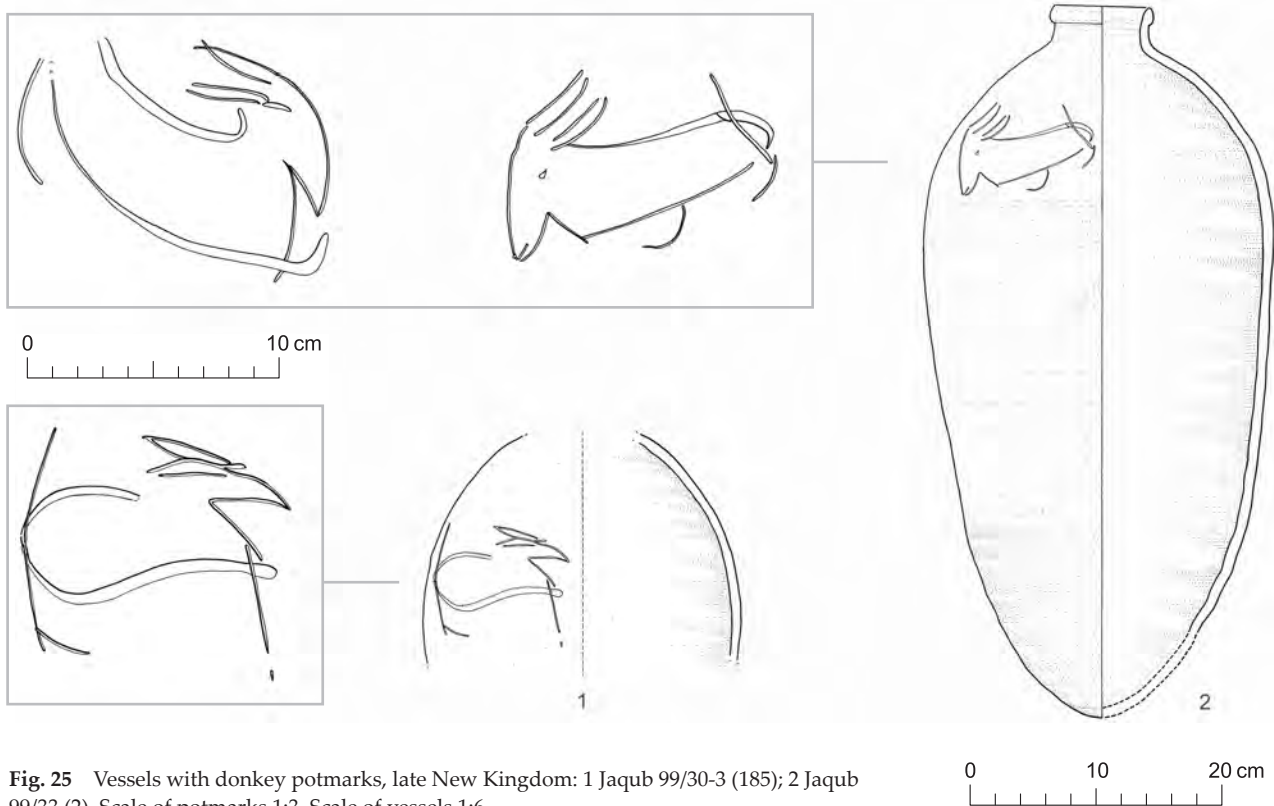

Fig. 25 Vessels with donkey potmarks, late New Kingdom: 1 Jaqub 99/30-3 (185); 2 Jaqub 99/33 (2). Scale of potmarks 1:3. Scale of vessels 1:6.

it had been used for transporting large storage jars. The radiocarbon date points to the 19th or early 20th dynasty.

The type of jars from sites Jaqub 99/33 and Jaqub 99/30 has not been found on any of the other Abu Ballas Trail sites, with the possible exception of a single jar at site Jaqub 00/19.¹⁴ For sites Jaqub 99/33 and Jaqub 99/30, 95 and 71 storage jars respectively were identified, and the original number probably was not much higher. These two sites are certainly part of the same operation, as is remarkably illustrated through potmarks (incised before firing) representing donkeys. One example was found on each site [Fig. 25], but they were probably made by the same person.¹⁵ Although the two sites are certainly related, they are located rather close to each other. Site Jaqub 99/33 is situated at a distance of at least three days by donkey from Dakhla (c. 120 km from Balat/Ayn Asil and c. 90 km from Mut el-Kharab), but site Jaqub 99/30 is only about 33 km further and normally it would not have been necessary to water the donkeys again at this place. As no late New

Kingdom vessels have been found further west on the Abu Ballas Trail, it is tempting to consider the two sites involved as evidence for an aborted undertaking (cf. Förster, this volume).

14 Possibly, this type of jar was also present at site Abu Ballas 85/55 ('Pottery Hill'), as can be seen on a photo from the 1980s taken by K.P. Kuhlmann (Kuhlmann 1988: pl. 51,f, bottom left and right). One of the two vessels on this photo has a pointed base, while the inside of the other jar does not show finger strokes but is turned, both of which are characteristics of the jars from sites Jaqub 99/30 and Jaqub 99/33. If indeed this is correct, it would push the distance from Dakhla (Balat), at which such jars are found, from 153 to 207 km. Unfortunately, the jars visible on the photo mentioned above were not among the material retrieved and studied for site Abu Ballas 85/55. Therefore, confusion remains possible with the 18th dynasty pottery certainly present for site Abu Ballas 85/55.

15 At site Jaqub 99/33, a second, incomplete and highly eroded example was found: Jaqub 99/33 (472C).

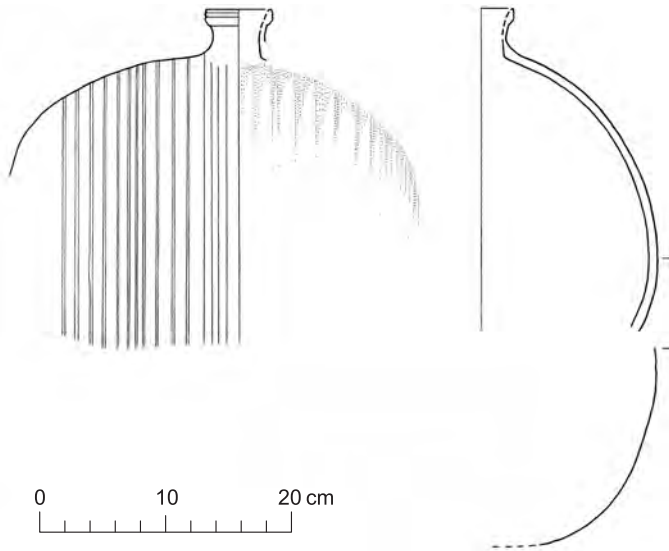

Fig. 26 Keg, Roman. Jaqub 00/23 (W437). Scale 1:6.

7. Roman

Occasionally, fragments of pottery turned on the kick wheel were found. Most of them are probably Roman. Kegs are the main identifiable vessel type, fragments of which have been found at a few sites, but the shape was only reconstructed for one example from site Jaqub 00/23 [Fig. 26]. It is barrel-shaped with a short neck and is made in an oasis fabric. Besides this keg with ribbed surface, frag-

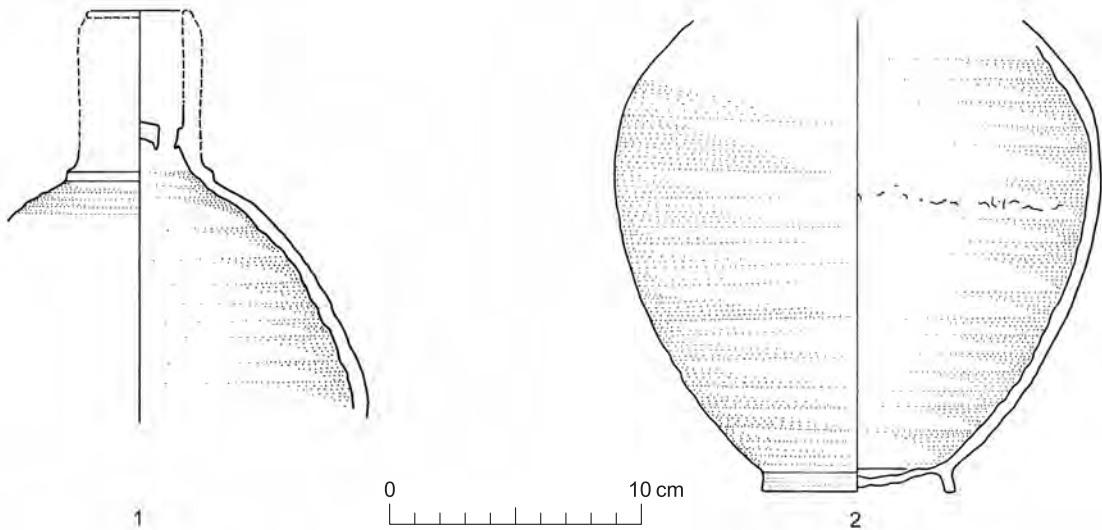

Fig. 27 Qullas, Roman (or Byzantine period): 1 Meri 99/55 (W152); 2 Meri 99/55 (W153). Scale 1:3.

ments of other kegs with smooth surface were also present at the same site, within a concentration of sherds. This ensemble has not yet been investigated but the rim type, with distinct ribs, confirms a date in the Roman period. Unfortunately, the typology and chronology of the Roman kegs remain largely unknown (cf. Ballet 1998: 39, fig. 11; Hope 1999: 232; 2000: 189, fig. 6c; see also Marchand 2000; Aston 2007: 441f.). For the few uncharacteristic fragments of kegs from other sites, nothing can be said with certainty, but they most probably also date to the Roman period.

At site Meri 99/55, two *qullas* (a water bottle with a filter in its neck that is still used in Dakhla today, cf. Henein 1997: 104–108; 154f.) were found, both of them made in an oasis fabric [Fig. 27]. Given their fragmentary preservation, it is not possible to confirm for certain that they belong to the Roman (or Byzantine) period, although this seems most likely.

No pattern can be recognised in the distribution of the sites where Roman pottery has been found. This, however, is not really surprising given the fact that by that time camels were used for desert travel and transportation (cf. Shaw 1979). A rather important water supply is only identifiable at site Jaqub 00/23. This site is situated 173 km from Dakhla (Balat), but camels could easily travel further from the oasis without needing water (cf. Shaw & Newbold 1928; Schmidt-Nielsen 1965: 33–70).

8. 'Filling stations' along an ancient desert highway

Only a few years after the discovery of the main pottery deposit at Abu Ballas in 1923, P. Borchardt (1929: 304) and R.A. Bermann (1934: 458f.) independently related this mysterious assemblage of storage jars in the midst of the desert to a report given by Herodotus, the Greek 'father of historiography' (cf. also Almásy 1936: 87f.):

(6) τὸ δὲ ὀλίγοι τῶν ἐς Αἴγυπτον ναυτιλλομένων ἐννενώκασι, τοῦτο ἔρχομαι φράσων. ἐς Αἴγυπτον ἐκ τῆς Ἑλλάδος πάσης καὶ πρὸς ἐκ Φοινίκης κέραμος ἐσάγεται πλήρης οἴνου δις τοῦ ἔτεος ἐκάστου, καὶ ἐν κεράμιον οἴνηρον ἀριθμῶ κεινὸν οὐκ ἔστι ὡς λόγῳ εἰπεῖν ιδέσθαι. κοῦ δῆτα, εἴποι τις ἄν, ταῦτα ἀναισιμουῦται; ἐγὼ καὶ τοῦτο φράσω· δεῖ τὸν μὲν δήμαρχον ἕκαστον ἐκ τῆς

ἑωυτοῦ πόλιος συλλέξαντα πάντα τὸν κέραμον ἄγειν ἐς Μέμφιν, τοὺς δὲ ἐκ Μέμφιος ἐς ταῦτα δὴ τὰ ἀνυδρα τῆς Συρίας κομίζειν πλήσαντας ὕδατος. οὕτω ὁ ἐπιφοιτέων κέραμος καὶ ἐξαιρεόμενος ἐν Αἰγύπτῳ ἐπὶ τὸν παλαιὸν κομίζεται ἐς Συρίην. (7) οὕτω μὲν νυν Πέρσαι εἰσὶ οἱ τὴν ἐσβολὴν ταύτην παρασκευάσαντες ἐς Αἴγυπτον, κατὰ δὴ τὰ εἰρημμένα σάξαντες ὕδατι, ἐπεῖτε τάχιστα παρέλαβον Αἴγυπτον. [...]

"(6) I will now mention something of which few voyagers to Egypt are aware. Throughout the year, not only from all parts of Greece but from Phoenicia as well, wine is imported into Egypt in earthenware jars; yet one might say that not a single empty wine-jar is to be seen anywhere in the country. The obvious question is: what becomes of them? I will explain. The local official of each place has orders to collect all the jars from his town and send them to Memphis, and the people of Memphis have to fill them with water and send them to this tract of desert in Syria. In this way every fresh jar of wine imported into Egypt, and there emptied of its contents, finds its way into Syria to join the previous ones. (7) It was the Persians, immediately after their conquest of Egypt, who devised this means of storing water in the desert, and so making the passage into the country practicable. [...]" (Herodotus III, 6–7)¹⁶

This 'technique' of storing water along routes through barren desert regions is obviously an age-old practice and was certainly not 'invented' by the Persians in the late 6th century BC. Many such pottery deposits, usually stumbled upon by accident in modern times, are known from various parts of the Libyan Desert and elsewhere (cf. Kemal el Dine & Franchet 1927; Almásy 1936: 87f.; Kuhlmann 1988: 69, n. 444; 2002: 147; Förster 2011: chapter 9.2). However, most of them seem to date to rather recent epochs, i.e. to Late Period, Ptolemaic, Roman or even Islamic times, and some of them are situated rather close to inhabited areas. For example, a site called 'Abu Zala' where the remains of about 1000 Roman vessels were found, is only some 30 km north of Birket Qarun (Fayum Oasis) (cf. Kemal el Dine & Franchet 1927: 597f., figs. 258; 259; Almásy 1936: 87f.; Caton-Thompson & Gardner

¹⁶ Translation by A. de Sélincourt (1954) as given in Herodotus: The Histories. Translated by Aubrey de Sélincourt. Revised with Introduction and Notes by John Marincola. London et al.: Penguin Group (revised edition 2003): 172.

1934: 9; 158, pl. 100,2). Another example is a recently discovered dump of c. 40 Roman (?) kegs, all deliberately destroyed with a pointed implement, about 80 km southwest of Mut/Dakhla (not related to the Abu Ballas Trail; cf. Förster et al. 2010: 55, figs. 2.4; 2.5; Riemer 2011: 238–240) [Fig. 28].

Accordingly, it has been assumed for a long time that such isolated pottery concentrations in the desert were the remains of water supply stations – called ‘mahatta’ or ‘mahatteh’ in Arabic (Winlock 1936: XI) – that were established and used during comparatively late periods when the camel had already been introduced into northeastern Africa. In the case of the old pottery dump at Abu Ballas, it was even suggested that it may relate to Tibu nomads from the southwest who used it as a supply base for their raids on Dakhla in recent centuries (Kemal el Dine & Franchet 1927: 596f.; Ball 1927: 122f.; Hoellriegel 1938: 44f.). Another proposal was to connect it “with Cambyses’ ill-fated expedition from Dakhla to subdue the Ammonites of Siwa”

(Jarvis 1936: 115; cf. Bermann 1934: 458f.; Hoellriegel 1938: 46–48): According to Herodotus (III, 25–26), shortly after the conquest of the Nile Valley the Persian king Cambyses (529–522 BC) sent an army consisting of 50,000 soldiers from Thebes to Siwa Oasis via Kharga and Dakhla. Reportedly, the whole army was surprised en route by a sudden exceptionally strong sandstorm, and disappeared without a trace somewhere in the Great Sand Sea. Also the Hungarian desert explorer L. Almásy thought of Abu Ballas as an artificial water station established for camel caravans at some point during the first millennium BC. In his opinion, it marked the first third of a route connecting Dakhla with the Kufra Oases in modern Libya, and one of the ‘green’ valleys of the western Gilf Kebir, Wadi Abd el-Melik (which he claimed was the legendary lost oasis of ‘Zarzura’), was another intermediate stop after two thirds of the distance (Almásy 1999: 108f.; cf. Almásy 1936: 87f.). Caravans consisting of camels that are able to go for several days without



Fig. 28 The remains of a Roman (?) pottery deposit about 80 km southwest of Mut/Dakhla. The site (Jaquib 02/100) is several kilometres off the Abu Ballas Trail and consists of about 40 large kegs, all deliberately destroyed with a pointed implement.

Fig. 29 Supply depot, including four large storage jars, of Nubian mercenaries patrolling the desert around the city of Akhenaten. Depiction in the rock tomb of Mahu, chief of police of Amarna, 18th dynasty (detail from Davies 1906: pl. 26).

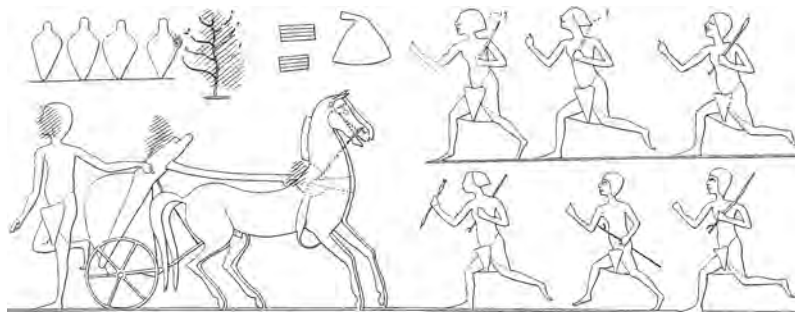

water (cf. Shaw & Newbold 1928; Schmidt-Nielsen 1965: 33–70) would of course not need more intermittent watering stations to cover such distances.

Gertrude Caton-Thompson, in view of a photograph of one of the late Old Kingdom/early First Intermediate Period storage jars found at Abu Ballas, was the first scholar who, in 1934, assumed that this kind of vessel may actually belong to an early period of Pharaonic civilisation when the principal beast of burden was the donkey: “The form [...] recalls a certain shape of the earliest Egyptian dynasties” (Caton-Thompson in Bermann 1934: 467). This statement is introduced by the following words (op.cit.: 466):

“[...] When great dumps of pottery, which are not uncommon over parts of the Libyan Desert, are discovered, there is a tendency to conclude that they indicate comparatively late caravan trade movements in the desert, somewhere in the Roman, Ptolemaic, or at earliest the Persian periods. I am not at all sure that is always the case. I know dumps containing 300 or 400 of these great amphorae which are undoubtedly of Roman or Ptolemaic age. But I think it is becoming more and more apparent that the ancient Egyptians also went far out into the desert in search of some of those beautiful rocks with which they made certain of their stone vessels. There was a striking example of that the winter before last, when, in the Western Nubian Desert, a new source for particular varieties of diorite was quite accidentally discovered [i.e. the so-called Chephren’s Quarries at Gebel el-Asr, about 80 km west of Toshka, cf. Engelbach 1933; 1938; Murray 1939]. That quarry dates back to the Old Kingdom of the third millennium. [...]”

At present, a number of pottery dumps that definitely date back to comparatively early periods of Pharaonic civilisation are known; these dumps were obviously used as supply depots for movements in the desert. Examples are Abu Ziyâr on the

Girga Road between the Nile Valley and Kharga Oasis (cf. Darnell, this volume), and a collection of more than 20 large storage jars of 12th dynasty times recently excavated at Gebel el-Asr (Shaw 2009: 74f., fig. 4; Shaw et al. 2010: 300f., fig. 6). Today it can hardly be doubted that the ancient Egyptians’ use of desert routes for long-distance travel, trade, communication, and exploitation of natural resources was much more common than hitherto assumed. The rather limited number of Pharaonic pottery deposits currently known is probably only a consequence of the fact that, so far, only little systematic research has been carried out in order to detect and properly investigate such routes.

Looking for relevant ancient Egyptian pictorial or textual evidence, it comes as no surprise that this quite ordinary ‘technique’ of storing provisions in the desert was barely mentioned or depicted in the available sources (cf. Förster 2011: chapter 9.3). Nevertheless, there are a few indications. For instance, a representation in the 18th dynasty rock tomb of the chief of police Mahu at Amarna shows a number of Nubian soldiers patrolling the desert around the city of Akhenaten, and four large storage jars as well as a bag and two other items are depicted as placed next to a little acacia tree, indicating a depot of provisions used by the group [Fig. 29] (for somewhat similar scenes, see Hayes 1953: 160, fig. 96; Davies 1963: pl. 2). As for related textual evidence, a short Middle Kingdom rock inscription may be mentioned [Fig. 30]. It is located at Tenida in the eastern part of Dakhla, from where two caravan routes, the Darb el-Ghubari and Darb el-Ayn Amur, lead to Kharga Oasis. The inscription records the creation of a water reservoir that had been ordered by a local governor’s son (*s3 h3ty-ꜣ*) called Mery. Although the reading of the quite unusual hieroglyph – three water-lines framed on three sides by a sim-

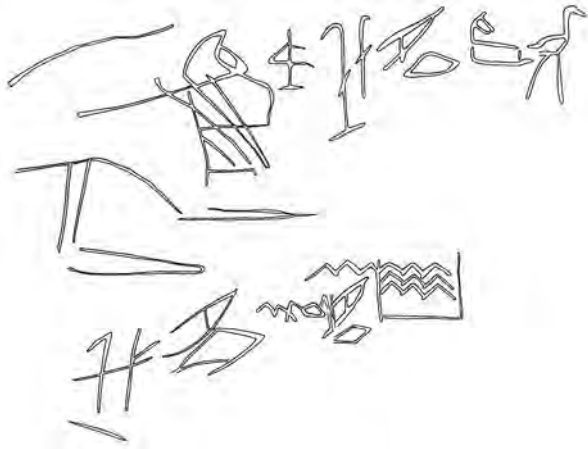

Fig. 30 Middle Kingdom rock inscription at Tenida in the north-eastern outskirts of Dakhla (Baud et al. 1999: fig. 4). It records the creation of a water reservoir – possibly a dump of storage jars – that had been ordered by a local governor’s son called Mery.

ple line – remains unclear, it may well denote a water supply stored in ceramic vessels, rather than a well dug at this place (cf. Baud et al. 1999: 3f.). Another, though indirect attestation is provided by a letter written on a clay tablet that was excavated in the late Old Kingdom governor’s palace at Ayn Asil. It mentions a potter who had been sent to one of the villages in the oasis’ outskirts in order “to prepare a way” (*r irt w3t*) for the chief of a foreign region called Demi-iu (Pantalacci 1998: 306–310, fig. 1). Most probably, the potter’s task was to produce some storage jars that were to be placed, filled with water, along a desert route to facilitate movements of foreign groups coming to Dakhla. There is even reason to assume that the route in question was the Abu Ballas Trail (cf. Förster, this volume). The laconic phrase *wb3 w3t* “to open (i.e. to make passable) a way” through barren regions, which occurs in autobiographical texts of expedition leaders such as Harkhuf, might very well refer to – or imply as one measure – the application of the same ‘technique’ for preparing long-distance desert travels in Pharaonic times (Erman & Grapow 1926–1931, vol. 1: 290,8–9; cf. Kuhlmann 2002: 139f.; 142, n. 21).

In the Eastern Desert of Egypt, the general situation was much different because wells or cisterns were available at places, and the distances to be covered were relatively short (cf. Bard et al., this volume). Henu, an official under the reign of Mentuhotep III (11th dynasty), boasts in a rock

inscription of having “turned a (desert) road into a river”, in order to lead an expedition consisting of 3000 men from the Nile Valley to the Red Sea coast (and further on by sea to Punt). He did so by constructing no less than 15 ‘wells’ (*hnmwt*; for the various meanings of this term, see Franzmeier 2008) along the Wadi Hammamat where his inscription was found (Cuyat & Montet 1912: pl. 31, no. 114; cf. Lichtheim 1988: 53; Gasse 1994: 170; 173f.). Nevertheless, in view of the limited availability of natural water sources in this area, Henu might also have placed some pottery dumps as additional supply stations for the c. 150 km long journey across the desert (for similar chains of wells or cisterns along desert routes used in Pharaonic times, see Hoffmeier & Moshier, this volume; Snape, this volume; Darnell 1986: 19f.).

Until the discovery of the Abu Ballas Trail and its stations there was no firm archaeological evidence of any *chains* of such pottery deposits along specific desert routes in Egypt, either of Pharaonic date or more recent. To our knowledge, the only (possible) exception is a sequence of sites between Abydos and northern Kharga, which yielded various amounts of ceramic remains (Caton-Thompson 1931: 78; 1952: IXf., pl. 126; cf. Roe 2005–2006: 128; Graeff 2005: 75–80). Notably, it was G. Caton-Thompson and her team who discovered and cursorily investigated these remains during an expedition by camels in the early 1930s: “The route we followed from the Nile valley to Kharga is dotted with Roman watering stations, placed at regular intervals: five big ones were noted and their positions fixed; they consist now of litters or piles of broken amphorae, reddening the ground where they lie” (Caton-Thompson 1931: 78). According to a map later published by Caton-Thompson (1952: pl. 126), however, these sites are all situated within the first half of the c. 150 km long route, and the distances between them range between c. 4 and 12 km only. This pattern of distribution raises considerable doubts as to whether these main pottery concentrations (as well as some minor ones) indeed belong together as elements of the same desert operation(s) – the distances between the ‘watering stations’ are much too short to reflect daily travel rates, either by camel or donkey.

Against this background, the comparatively well preserved archaeological evidence of the Abu Ballas Trail provides, for the first time, valuable insights

into the ancient ‘technique’ mentioned – but not described in detail – by Herodotus for the late 6th century BC. Moreover, it proves that the application of this logistical method for long-distance desert travel already occurred in the late third millennium BC – and for remote regions that hitherto have been regarded as *terra incognita* for the ancient Egyptians. Given that the climatic and environmental settings in those times did not differ much from today (cf. Kuper & Kröpelin 2006), a crossing of the vast, waterless terrain between Dakhla and the Gilf Kebir by donkey caravans indeed would hardly have been possible without taking such measures. As already pointed out above (and in contrast to what Herodotus wrote), the storage jars certainly were transported empty and only after they had reached their final destination at the individual supply stations, were they filled with water that had been carried separately in much lighter and less vulnerable waterskins. The successive installation of these supply stations from the Dakhla Oasis up to the Gilf Kebir and the repeated refilling of their storage capacities when going back and forth was evidently an enormous effort, which exponentially increased with the distance and certainly involved many donkey convoys. Of course, the latter needed their own provisions during this preparation phase, and only a fraction of their freight could be deposited at selected places. Once all the ‘filling stations’ were ready for use, they resembled to some extent the Roman *hydremata*, chains of fortified wells that were usually established at intervals of c. 20–30 km along routes in the Eastern Desert (cf. Peacock 1997: 266; 2000: 434f.; Hamilton-Dyer 1998: 123f., fig. 17.1). An example is the quarry road to Mons Claudianus: “Each station is approximately 25 km from the next, which coincides with the distance a loaded pack donkey could be expected to travel per day” (Hamilton-Dyer 1998: 124).

The daily travel rate of a train of loaded pack donkeys certainly also determined the shape of the logistical infrastructure of the Abu Ballas Trail. However, the distances between the main supply depots along the route are considerably larger compared to the more conveniently placed *hydremata* of Roman times [cf. Tab. 2].¹⁷ The key to understanding the general distribution pattern of the principal watering stations in Pharaonic times is provided by the distance between the late Old Kingdom/First Intermediate Period sites Jaqub

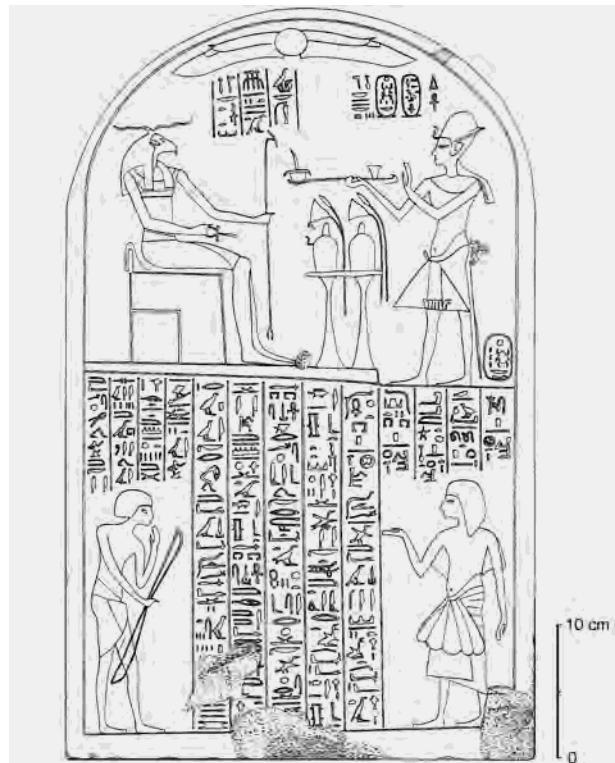

Fig. 31 A small sandstone stela, found in the surroundings of the Kurkur Oasis in Lower Nubia and dating to the reign of Tutankhamun, 18th dynasty (Darnell 2003: fig. on p. 76). The text mentions the daily duty of a Medjai soldier (and perhaps a small, lightly armed and provisioned group) to patrol a desert route between Aswan and Kurkur, probably in the region of the Sinn el-Kaddab escarpment. The distance to be covered each day is specified as four *itrw*, i.e. about 42 km (cf. Darnell 2003: 82–84). According to Spalinger (2005: 34), who refers to textual data on the Meggido campaign of Thutmose III, “[...] an ordinary march by the Egyptian army in Dynasties XVIII–XX would take about 16 to 24 km/day maximum” (cf. also Faulkner 1942: 2; Redford 2003: 202). One may, therefore, assume that the normal pace of a heavily loaded donkey caravan in ancient Egypt was somewhere in between that of a light patrol, on the one hand, and that of large troops, on the other, leading to an average daily travel rate of c. 25–30 km, or slightly more.

99/31–32 (‘Muhattah Jaqub’ as labelled by C. Bergmann) and Abu Ballas 85/55, since both sites certainly were part of the same operation(s) and there are definitely no great dumps of pottery in between [cf. Tab. 1]. This distance, 78 km as the crow flies, most likely reflects the donkey’s ability to go without water for two or three days (cf. Seligman 1934: 69–71; Murray 1935: 102; Wainwright 1935: 260f.; Dill 1938: 104; 109; Keimer 1952–1953: 486;

17 Except for the distance between the late New Kingdom sites Jaqub 99/33 and Jaqub 99/30 (33 km as the crow flies), which constitutes a special case (see below).

Main supply station	Minimum storage capacity attested (litres)	Distance to Dakhla: Balat / Ayn Asil	Distance to Dakhla: Mut el-Kharab	Distance to previous main supply station	Average daily marching rate**
Late Old Kingdom / First Intermediate Period					
1.* Meri 99/58–59 (or surroundings)	≥ 156	49 km	19 km	-	-
2. Jaqub 99/31–32	2010	129 km	99 km	c. 80 km	c. 27 km
3. Abu Ballas 85/55	≥ 3030	207 km	177 km	78 km	26 km
4. Base Camp 00/27	≥ 1200	271 km	241 km	64 km	21 km
5.* El-Nahud 00/7	≥ 600	359 km	329 km	88 km	29 km
New Kingdom: 18th dynasty					
1. Jaqub 99/34	≥ 800	105 km	75 km	-	-
2. Abu Ballas 00/25	≥ 800	177 km	147 km	72 km	24 km
3.* [N.N.]	[≥ 800?]	[c. 252–267 km]	[c. 222–237 km]	[c. 75–90 km]	[c. 25–30 km]
4.* El-Nahud 00/6	220 [+ x?]	350 km	320 km	[c. 83–98 km]	[c. 28–33 km]
Late New Kingdom: 19th/20th dynasty (Ramesside Period)					
1. Jaqub 99/33	1900	120 km	90 km	-	-
2. Jaqub 99/30	1420	153 km	123 km	33 km	11 km

* Hypothetical or questionable.

** Assuming a three day journey by donkey caravan between the individual main supply stations (see text).

Tab. 2 Spatial distribution and minimum storage capacities of the main supply stations along the Abu Ballas Trail [cf. Fig. 32]. Distances are given as the crow flies.

Groves 1974: 110; Jones et al. 1989; Osborn & Osbornová 1998: 132; Adams 2007: 58). There is no reason to assume that the ancient Egyptians did not take full advantage of this special ‘quality’ of the domesticated donkey which, as the principal beast of burden in those times, was probably bred in significant quantities in the Dakhla Oasis. Thus, the pack animals either walked c. 40 km per day and were watered at the end of every second, or they needed three days at a rate of c. 25–30 km to cover the distance, getting their water at the end of every third. Though the former figure cannot be excluded, comparative data, both of ancient (see, e.g., Spalinger 2005: 34; Darnell 2003 [Fig. 31]; cf. Dercksen 2004: 255f., n. 656, 703; Nashef 1987: 62f.; 65f., n. 39, 43) and more recent times (cf. Förster et al., this volume), suggests the latter to be more realistic under the given circumstances (for details, see Förster 2011: chapter 11.2). Moreover, the positions of intermediate, smaller sites where people could spend the night before arriving at a main supply depot (or after leaving one) support such an interpretation (see above; cf. Tab. 1).

The positions of the other main supply stations, placed at distances ranging from 64 to c. 90 km [Tab. 2], fit quite well into this general scheme. The variations in interval lengths are most probably

due, first of all, to the various landscape units to be crossed by the caravans, exhibiting different terrains in terms of topography and surface cover (cf. Riemer, this volume: fig. 20). For example, the rather short distance of 64 km between Abu Ballas 85/55 and Base Camp 00/27 can easily be explained by the fact that along this part of the route the Abu Ballas Scarp had to be crossed, an incline (or rise, depending on the direction of movement) of more than 200 metres. Steep escarpments, frequent ups and downs in hilly or mountainous country as well as very soft, sandy subsoils or even dune trains as natural obstacles would certainly have increased the journey time, whereas compact soils on level ground would have facilitated rapid movement. The physical shape of the country is however only one of the factors that might have had an impact on daily travel rates (cf. Meerpohl 2009: 176ff.; this volume; Förster et al., this volume). In a word, one cannot expect a mathematically exact distribution of supply depots, but rather one that had been dictated by practical considerations and experience.

As for the establishment and earliest use of the trail in the late Old Kingdom/First Intermediate Period, four (main) watering stations can be identified (from northeast to southwest) [cf. Tab. 2; Fig. 32]: Jaqub 99/31–32 (‘Muhattah Jaqub’/1–2) [Fig. 33; cf.

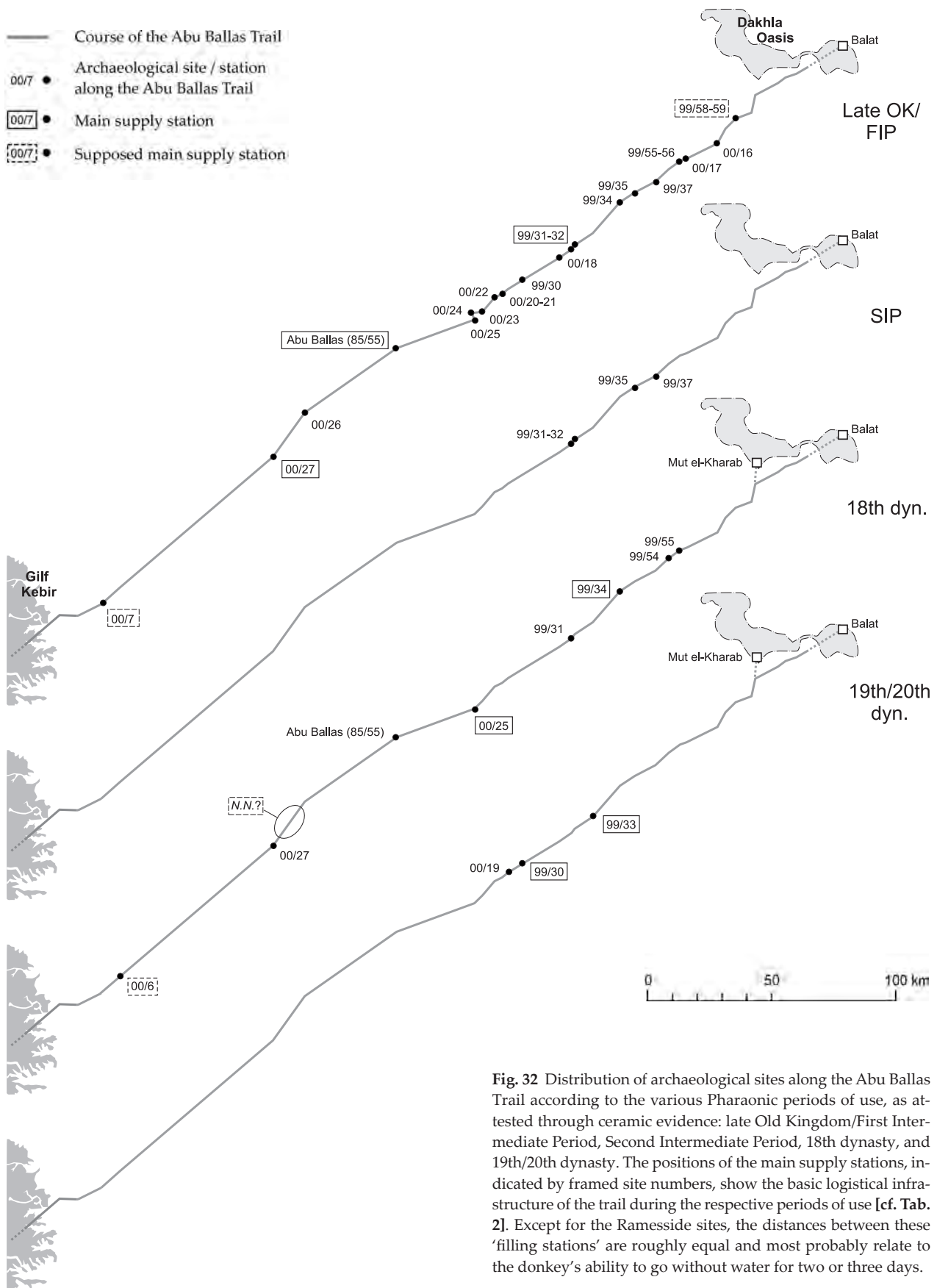

Fig. 32 Distribution of archaeological sites along the Abu Ballas Trail according to the various Pharaonic periods of use, as attested through ceramic evidence: late Old Kingdom/First Intermediate Period, Second Intermediate Period, 18th dynasty, and 19th/20th dynasty. The positions of the main supply stations, indicated by framed site numbers, show the basic logistical infrastructure of the trail during the respective periods of use [cf. Tab. 2]. Except for the Ramesside sites, the distances between these 'filling stations' are roughly equal and most probably relate to the donkey's ability to go without water for two or three days.

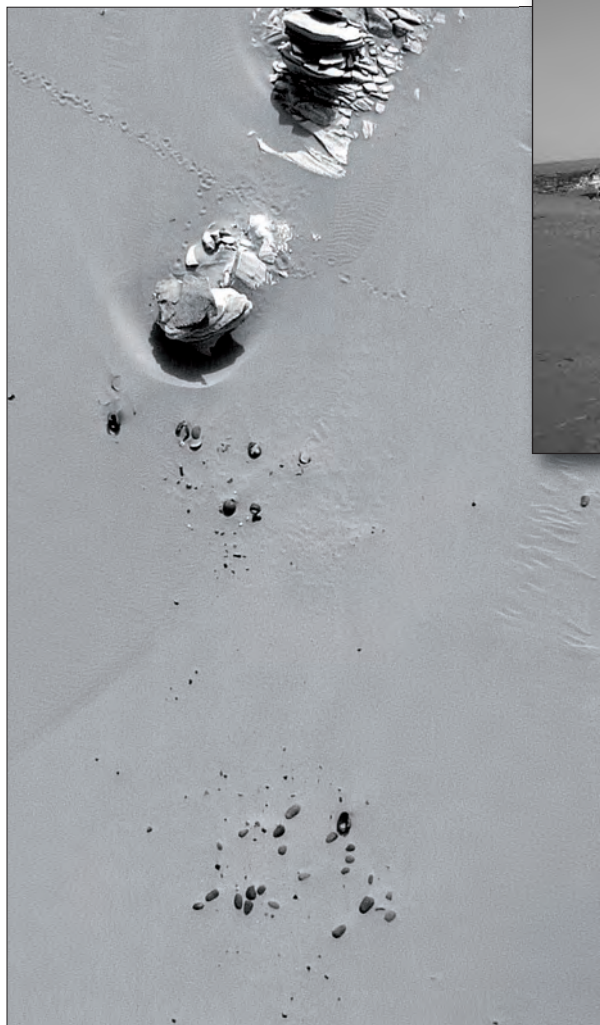

Fig. 33 Aerial photograph, taken by means of a camera-bearing kite, of late Old Kingdom/First Intermediate Period pottery deposits at site Jaqub 99/31 ('Muhattah Jaqub'/1) (left). On the right, another concentration of vessel remains at the same site, viewed from the ground.

Fig. 10.2], Abu Ballas 85/55 (the original Abu Ballas or 'Pottery Hill' site: Förster, this volume: fig. 3; cf. **Fig. 10.1**), Base Camp 00/27 ('Muhattah Fatima'), and El-Nahud 00/7 ('Muhattah Rashid'). According to the logistic scheme described above, another main station presumably existed between Dakhla and Jaqub 99/31–32, probably at site Meri 99/58–59 ('Muhattah el-Askeri' /1–2) or its surroundings. At a distance of c. 49 km from Balat and less than 20 km from the oasis' southwestern outskirts, this position is rather close to Dakhla. In terms of logistical efficiency while building up a chain of supply stations, however, such a placement of the first stepping stone in the desert would make perfect sense: Donkey convoys carrying provisions to be stored there would not need to consume part of their valuable freight but could have returned to Dakhla without drinking water. The fact that no huge amounts of

late Old Kingdom/First Intermediate Period storage jars have yet been detected at 'Muhattah el-Askeri' or its surroundings [**cf. Tab. 1**] might be explained by the possibility that, considering the short distance from the oasis, many intact jars had been removed in later times, and reused in Dakhla for other purposes. A number of simple stone structures found at 'Muhattah el-Askeri' (cf. Bergmann 2001: fig. facing p. 368) seem to support this view since they are also known from main supply stations further to the southwest where they probably served as basins for watering or feeding donkeys [**cf. Figs. 34; 35**].

A slightly different pattern of distribution can be observed for the 18th dynasty activities along the route (the previous Second Intermediate Period activities did not leave any great pottery dumps at all, pointing to small-scale operations for which no huge numbers of pack animals were needed). Two sites, Jaqub 99/34 ('Muhattah Amphorae') [**Fig. 34**] and Abu Ballas 00/25 ('Bint Ballas'), certainly served as principal watering stations, and most probably also site El-Nahud 00/6 ('Khasin Berlin') [**cf. Fig. 14**], though the vessels at the latter site were probably not found in their original position. This constellation proves that the trail had been travelled along in its full length up to the Gilf Kebir during those times and, consequently, a fourth main watering

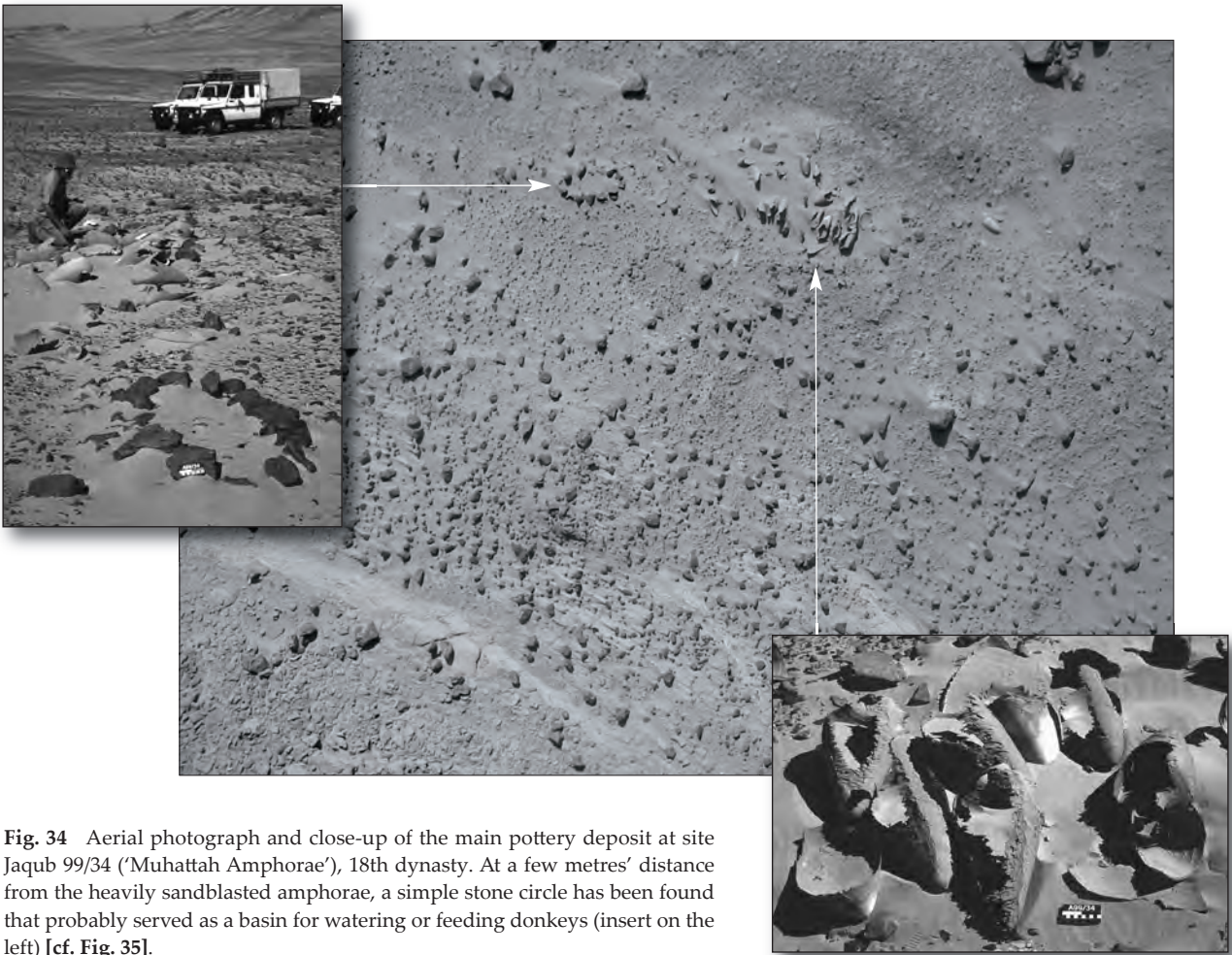

Fig. 34 Aerial photograph and close-up of the main pottery deposit at site Jaqub 99/34 ('Muhattah Amphorae'), 18th dynasty. At a few metres' distance from the heavily sandblasted amphorae, a simple stone circle has been found that probably served as a basin for watering or feeding donkeys (insert on the left) [cf. Fig. 35].

station must have existed between Abu Ballas 00/25 and El-Nahud 00/6, the remains of which are yet to be discovered ('N.N.' in **Tab. 2** and **Fig. 32**). Compared to the late Old Kingdom/First Intermediate Period of use, the distances between the main supply stations are more or less the same, but the individual stations were placed much further to the southwest. This shifted pattern of distribution might very well be explained by the rise of Mut el-Kharab, a settlement situated in the southwestern part of Dakhla which became the oasis' capital in the New Kingdom (cf. Hope 2005; Hope et al. 2008). While trade caravans of the late Old Kingdom/First Intermediate Period in all probability started at (or aimed for, depending on the direction of movement) the local governor's residence in Balat/Ayn Asil in the northeastern part of Dakhla, this new point of departure (or arrival) would have consid-

erably reduced both the logistical efforts and the journey time. Now, the establishment and maintenance of only four, instead of five, main supply stations between Dakhla and the Gilf Kebir would have sufficed to enable donkey caravans to cover the whole distance within less than two weeks. However, both the rather small number of 18th dynasty sites in general [cf. **Tab. 1**] as well as the limited amount of storage capacities at the main watering stations [cf. **Tab. 2**] seem to point to a lower intensity of traffic when compared to the late Old Kingdom/First Intermediate Period. Despite of a more efficient logistical infrastructure, the activities during the 18th dynasty along the Abu Ballas Trail were probably restricted to a relatively short period of time.

Little can be said in terms of logistics and organisation for the activities in the Ramesside Period



Fig. 35 Aerial photograph of the Ramesside pottery dump at site Jaqub 99/33 ('Muhattah el-Homareen') before excavation. In the upper right corner of the picture, the remains of a small stone circle are visible, similar to the one detected at site Jaqub 99/34 [cf. Fig. 34]. As the insert on the right illustrates, such simple stone structures are still used in modern Sudan for watering camels or other pack animals (van der Stappen 2007: fig. on p. 330). The insert on the left shows the detail of four jars placed in a row, probably representing a batch of containers that had been carried along by a single donkey.

(19th/20th dynasty). Apart from a single jar found at site Jaqub 00/19, there are only two sites dating to this period [cf. Tab. 2; Fig. 32]: Jaqub 99/33 ('Muhattah el-Homareen') [Fig. 35] and Jaqub 99/30 ('Muhattah Umm el-Alamat'). Both sites, however, range among the greatest dumps of pottery discovered along the route, and, as outlined above, they were certainly part of the same desert operation, for which all the vessels had been specially produced. While Jaqub 99/33 is situated at a distance of c. 90 km from Mut el-Kharab (and, therefore, still fits into our general scheme), site Jaqub 99/30 is only 33 km further, i.e. about a single day's march by donkey. Given that no late New Kingdom dumps have been found further west on the trail, there is

little doubt that the sites represent a failed attempt to build up another chain of supply stations – an undertaking that was perhaps hampered by a sudden sandstorm, and never taken up again.

Admittedly, the above reconstruction of the individual patterns of distribution is to some extent hypothetical, due to a number of gaps in the available archaeological record (cf. Förster 2011: chapter 12). This also holds true for attempts to estimate the size of trade caravans and, in turn, the amount of goods that could have been transported along the route once all the stations and deposits were ready for use. Nevertheless, approaches and rough calculations are possible by applying some general data. The basic question is: How much water was avail-

able at each main supply station, and how many donkeys could thereby be provisioned? Although only very few vessels have been found complete and could be used to directly determine their capacities, a considerable number of broken and/or highly eroded remains of additional jars facilitated rather accurate reconstructions in scale drawings. By applying the so-called ‘summed (or stacked) cylinders’ method [cf. Fig. 36], it was possible to estimate the volume of, all in all, 58 storage jars or amphorae, based on their reconstructed profiles: 35 of late Old Kingdom/First Intermediate Period age, 7 of 18th dynasty, and 16 of Ramesside times (cf. Förster 2011: chapter 10). It turned out that the average capacity of the large late Old Kingdom/First Intermediate Period storage jars is about 30 litres, whereas that of the New Kingdom amphorae of both periods concerned appears to be around 20 litres. Thus, the minimum storage capacities once available at the individual stations could be roughly calculated; the results are listed in **Tab. 2** (for the respective numbers of vessel units detected at the sites, see **Tab. 1**).

It goes almost without saying that the original number of jars was probably considerably higher at most of the sites under discussion. The circum-

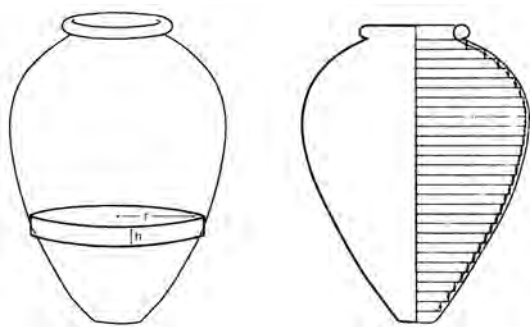

Fig. 36 The ‘summed (or stacked) cylinders’ method of estimating the volume of a vessel, based on the reconstruction of its profile in drawing (Rice 1987: 222, fig. 7.8, slightly modified). The vessel is divided into a series of equal horizontal slides or thin cylinders, the volume of each cylinder is calculated by the formula $V = \pi r^2 h$, and then these are summed to give an estimate of the total volume of the container (cf. also Thalmann 2007; Engels et al. 2009).



Fig. 37 The remains of some late Old Kingdom/First Intermediate Period storage jars found in the surroundings of site Jaqub 99/32 (‘Muhattah Jaqub’/2) in March 2004. Covered by a sand dune, the pottery was invisible during former visits to the site and was only recently exposed through wind action that had shifted the dune for some metres. This striking example confirms the assumption that more pottery concentrations along the Abu Ballas Trail still await discovery.

stances of extreme wind erosion in the desert may have caused the complete disappearance of some vessels, and others may have been removed or destroyed in ancient or more recent times. Moreover, a number of sites have not yet been excavated (here, only the exposed vessels visible on the surface have been counted), and it should be expected that some deposits along the route, as well as additional jars at already known stations, still await discovery [cf. **Fig. 37**]. Therefore, the given figures should be regarded as absolute minimum numbers.

Nevertheless, it can reasonably be argued that at each of the main supply stations used in the late Old Kingdom/First Intermediate Period about 100 large storage jars were originally deposited. This is cer-

tainly the case for Abu Ballas 85/55 (cf. Ball 1927: fig. facing p. 125, above = Förster, this volume: fig. 3; Gabriel 1986: 12f.) and can also be assumed for 99/31–32 ‘Muhattah Jaqub’, where the remains of 67 identifiable vessel units have been excavated. At Base Camp 00/27 ‘Muhattah Fatima’ and El-Nahud 00/7 ‘Muhattah Rashid’ the remains of only c. 40 and 20 jars, respectively, are currently known, but no excavations have been carried out and a considerable number of additional vessels might still be covered by sand (for the special case of Meri 99/58–59 ‘Muhattah el-Askeri’, see above). 100 storage jars would have provided about 3000 litres of water at each site. That amount might have sufficed for watering up to 100 donkeys, each getting c. 30 litres after a three day journey between the individual main supply stations.¹⁸ A caravan of such a size would not match the one that Harkhuf led back from Yam to Egypt in the late 6th dynasty: In the autobiographical text still preserved in his rock tomb at Qubbet el-Hawa near Aswan Harkhuf boasts of having returned with 300 donkeys laden with “all sorts of good products” such as incense, ebony, oils, panther skins and ivory (Sethe 1933: 126f.). But our estimate would be well comparable with the caravan mentioned by Sabni, one of Harkhuf’s successors as the governor of Upper Egypt, who undertook a trade expedition to Wawat in Lower Nubia, which consisted of 100 donkeys laden with various oils, honey, clothes and fayence (Sethe 1933: 136).

Any calculations, however, must also take into account the amount of provisions needed for the donkey drivers, although the number of humans accompanying a caravan was probably not very high (cf. Förster et al., this volume). Moreover, some of the jars deposited at the individual stations might not have been filled with water but with grain or other foodstuffs, in addition to both the provisions carried along and the (sparse) vegetation perhaps available along the route during the rainy season or shortly after, which could have been used as fodder for the pack animals. Therefore, a (minimum)

number of 75–90 donkeys per caravan seems perhaps more reasonable for the activities that took place during the late Old Kingdom/First Intermediate Period. Assuming an average payload of c. 60 kg per donkey (neglecting the additional weight of packing devices such as baskets or bags, ropes, pack saddles, and the weight of some provisions and equipment carried along), such a caravan would have been able to transport cargoes of c. 4.5–5.4 tons.

Compared under the same parameters, the expeditions during the 18th dynasty appear to have been considerably smaller in scale. Around 40–50 amphorae deposited at each of the main supply stations¹⁹ would have provided water for about 25–30 donkeys at best. Trade caravans of such a scale could have transported a freight of no more than c. 1.5–1.8 tons — i.e., a third of what was possible in late Old Kingdom/First Intermediate Period times. Finally, judging from the number and capacity of vessels excavated at sites Jaqub 99/33 ‘Muhattah el-Homareen’ [cf. Fig. 35] and Jaqub 99/30 ‘Muhattah Umm el-Alamat’ – 95 and 71 amphorae, respectively – it can be said that the aborted undertaking in Ramesside times aimed to pave the way for donkey caravans of a size and load capacity somewhere between those of the former two periods (for a more detailed discussion of these aspects, see Förster 2011: chapter 14, with further references).

Most probably, all these journeys were undertaken in the colder seasons, i.e. in winter or early spring, when water requirements of both humans and animals, usually walking in the daytime, were relatively low. In addition, winter rains might even have provided fresh grass in places, which could have been used as succulent fodder for the pack animals. Under the above assumptions, travelling the Abu Ballas Trail from Dakhla to the Gilf Kebir (or vice versa) by donkey caravan was a matter of around two weeks. Naturally, enabling a trade caravan to return to its starting-point was as important as the preparations for launching it, which raises the question of how long the water could be stored

18 The domesticated donkey can tolerate a dehydration of up to 30 % of its body weight (Maloiy 1970; Maloiy & Boarer 1971; Smith & Pearson 2005: 6f.). To repair such a deficit, a dehydrated donkey can drink 24–30 litres of water within 2–5 minutes when water becomes available (op.cit.).

19 At least at site Jaqub 99/34 ‘Muhattah Amphorae’, situated in a rocky area with stony subsoils where only very little sand has accumulated [cf. Fig. 34], the original number of jars probably would not have been much higher than the c. 40 vessel units detected during the surveys.

in the vessels. A number of factors might have had an impact on its evaporation rate: general climate, surrounding temperature and air humidity, fabric and quality of the clay, surface treatment of the vessels, duration of exposure to insolation, etc. (cf. Förster 2011: chapter 9.4). None of the storage jars found along the trail showed the application of special measures to decrease permeability, such as slipping the inner surface. However, regular slipping and polishing of the outer surface was still visible on many late Old Kingdom/First Intermediate Period jars (which probably have been closed with a piece of leather when filled), and might have diminished the porosity of the vessels to a sufficient degree. More important, however, is the general deposition and protection of the pottery dumps. Most of them were placed at, or near, the foot of a hill or close to a rock outcrop, which protected them to some extent against the sun and wind [Figs. 14; 33; 34; cf. Figs. 10.1; 28]. In general, the late Old Kingdom/First Intermediate Period deposits appear to have been installed more thoroughly and were better sheltered compared to the ones from the New Kingdom, probably reflecting a greater intensity of use and a need to maintain them for a longer period of time. According to Jarvis (1936: 114f.), the storage jars discovered at Abu Ballas in 1923 were found “buried in the soil [...]”, and they “were laid in orderly rows of ten”. This is also noted by Ball (1927: 122, n. †): “[...] the excavations made by the Prince [Kemal el Din] in the sand around the foot of the hill revealed the existence of hundreds of additional jars, many of them intact, set in regular order in the sand and obviously forming a water-dump”. Also at site Jaqub 99/31 ‘Muhattah Jaqub/1’, at least some storage jars seem to have been intentionally protected by a sand cover when left behind in Pharaonic times (cf. Förster 2011: chapter 6.1.4).

Under such favourable conditions, the loss of water during a storage period of some days or even weeks in the colder seasons would not be very high. Some evaporation through the vessel walls would even have had the benefit of keeping the water cool and fresh. The lapse of time between vessel filling and water consumption presumably ranged between a couple of days and a few weeks only, depending on the distance of the individual supply stations. And when a caravan was expected to come (or return) to Dakhla in the foreseeable future, all

the storage jars at the main stations probably could have been refilled at relatively short notice, albeit with considerable effort.

To sum up, an appraisal by G.A. Wainwright, dating back to the 1930s and not shared by many scholars in those days, can absolutely be confirmed in view of the evidence now on hand: “Hence, if they had the need, the ancients could have done a good deal of desert travel with their donkeys” (Wainwright 1935: 261). Provided they had enough storage jars and water bags, one might add.

9. Conclusions

The investigation of the Pharaonic pottery found along the Abu Ballas Trail provides valuable insights into several aspects of long-distance desert travel and transportation in ancient times when the principal beast of burden was the donkey. Various periods of use can be determined rather exactly, and the intensity of traffic can be estimated for each of the chronological phases. Ceramics – either used for transport, storage or as personal ‘tableware’ of the expedition members involved – usually constitute the most common type of find along ancient and more recent desert routes. The special case of the Abu Ballas Trail however offers some additional clues regarding the organisational and logistical framework necessary to conduct large-scale donkey caravan traffic over hundreds of kilometers through waterless regions. Various functions or types of pottery-bearing sites can be distinguished according to size, structure, complexity, the association with other artefacts, and the embedding in the landscape: temporary camp sites, main road stations, intermittent smaller supply depots, or localities where jars accidentally broken during transport had been left behind. Most informative, however, are the main supply stations consisting of dozens or even more than a hundred large storage jars once filled with water (and, in part, perhaps also grain or other foodstuffs) that have been deposited at rather regular distances for the donkeys and their drivers. Storage capacity and pattern of distribution of these supply depots make up the basic infrastructure of the trail, which likely was closely related to the donkey’s ability to go without water for two or three days and took full advantage of this quality. The calculated (minimum) amount of stor-

age capacities at the individual main supply stations in turn allows a rough estimate of the size and transport capacities of the donkey trade caravans that were launched once all the stations and deposits were ready for use.

The ceramic evidence available from the trail's sites is a stroke of luck for archaeology since these ancient activities are thereby not only datable (and can be related to specific historical situations, cf. Förster, this volume) but can be evaluated with regard to organisation and logistics as discussed above. Although a number of the sites had been disturbed to some degree in antiquity or more recently, most of them reflect the original situation when left behind after their last use in Pharaonic times. This is certainly due to the trail's general character as an extremely difficult desert route that required an enormous effort to be crossed by donkey caravans, and was, therefore, apparently only episodically used over many centuries, probably motivated in most cases by specific circumstances. In contrast to heavily trafficked caravan routes such as the famous Darb el-Arbain between the Darfur region in Sudan and Asyut at the Egyptian Nile, the archaeological features of the Abu Ballas Trail have only been shaped a little by later human activities. However, it must be kept in mind that desert circumstances causing extreme wind erosion may have led to the complete disintegration of some vessels. The original number of storage jars once placed at the individual supply stations was perhaps considerably higher, and the remains of some pottery deposits now covered by sand may still await discovery.

It is hoped that other long-distance desert routes exhibiting a similar logistical infrastructure of Pharaonic or 'pre-camel' times will be discovered in the near future, enabling comparison. For the time being, however, the Abu Ballas Trail constitutes the only known case where a detailed study and analysis of Herodotus' 'technique' of storing water along routes through arid wastes is possible.

Acknowledgements

The participation of Stan Hendrickx in the field work carried out by the ACACIA missions was made possible by grants from the Fonds Wetenschappelijk Onderzoek – Vlaanderen (Belgium). The large majority of the drawings presented in this article were made by Merel Eyckerman, but we gratefully acknowledge the additional illustration work of Bieke Van Gompel (2004) and Hannah Joris (2007). Thanks are also due to Elizabeth Hart for proof-reading the English text.

References

- Adams, C. (2007) *Land Transport in Roman Egypt. A Study of Economics and Administration in a Roman Province* (Oxford/New York: Oxford University Press).
- Almásy, L.E. (1934) *Az ismeretlen Szahara* [The Unknown Sahara] (Budapest: Franklin-Társulat).
- (1936) *Récents Explorations dans le Désert Libyque (1932–1936)*. Publications de la Société Royale de Géographie d'Égypte (Le Caire: Schindler).
- (1999) *Schwimmer in der Wüste. Auf der Suche nach der Oase Zarzura* (München: Deutscher Taschenbuch Verlag) [new and enlarged edition of Almásy, L.E. (1939) *Unbekannte Sahara. Mit Flugzeug und Auto in der Libyschen Wüste* (Leipzig: Brockhaus)].
- Arnold, D. (1982) *Keramikfunde aus Qila' el-Dabba*. In: J. Osing, M. Moursi, D. Arnold, O. Neugebauer, R.A. Parker, D. Pingree & M.A. Nur-el-Din, *Denkmäler der Oase Dachla aus dem Nachlaß von Ahmed Fakhry*. Archäologische Veröffentlichungen des Deutschen Archäologischen Instituts, Abteilung Kairo 28 (Mainz: Philipp von Zabern) 42–56.
- Aston, D.A. (1998) *Die Keramik des Grabungsplatzes Q I. Teil 1: Corpus of Fabrics, Wares and Shapes*. Grabungen des Pelizaeus-Museums Hildesheim in Qantir – Pi-Ramesse / Forschungen in der Ramses-Stadt 1 (Mainz: Philipp von Zabern).
- (2007) *Amphorae, Storage Jars and Kegs from Elephantine. A Brief Survey of Vessels from the Eighth–Seventh Centuries BC to the Seventh–Eighth Centuries AD*. Cahiers de la céramique égyptienne 8/2: 419–445.
- Ball, J. (1927) *Problems of the Libyan Desert*. *Geographical Journal* 70: 21–38; 105–128; 209–224.
- Ballet, P. (1990) *La céramique du Kôm I*. In: S. Aufrère, *La nécropole sud de Qila' al-Dabba (oasis de Dakhla, secteur de Balat), un palimpseste archéologique*. *Bulletin de l'Institut français d'archéologie orientale* 90: 18–28.
- (1998) *Cultures matérielles de déserts d'Égypte sous le Haut et le Bas-Empire. Productions et échanges*. In: O.E. Kaper (ed.), *Life on the Fringe. Living in the Southern Egyptian Deserts during the Roman and early-Byzantine Periods*. Proceedings of a Colloquium Held on the Occasion of the 25th Anniversary of the Netherlands Institute for Archaeology and Arabic Studies in Cairo 9–12 December 1996. CNWS Publications 71 (Leiden: CNWS) 31–54.

- Baud, M., F. Colin & P. Tallet (1999) Les gouverneurs de l'oasis de Dakhla au Moyen Empire. *Bulletin de l'Institut français d'archéologie orientale* 99: 1–19.
- Bavay, L., S. Marchand & P. Tallet (2000) Les jarres inscrites du Nouvel Empire provenant de Deir al-Médina. *Cahiers de la céramique égyptienne* 6: 77–89.
- Bergmann, C. (2001) *Der letzte Beduine. Meine Karawanen zu den Geheimnissen der Wüste* (Reinbek bei Hamburg: Rowohlt).
- Bermann, R.A. (1934) Historic Problems of the Libyan Desert. *Geographical Journal* 83: 456–470.
- Borchardt, P. (1929) Oasen und Wege der südlichen Libyschen Wüste. *Petermanns Geographische Mitteilungen* 75: 302–306.
- Burkard, G. (1997) Inscription in the Dakhla Region. Text, Translation and Comments. *Sahara* 9: 152–153.
- Castel, G. & L. Pantalacci (2005) Les cimetières est et ouest du mastaba de Khentika, Oasis de Dakhla. *Balat VII. Fouilles de l'Institut français d'archéologie orientale* 52 (Le Caire: Institut français d'archéologie orientale).
- Castel, G., L. Pantalacci & N. Cherpion (2001) Le mastaba de Khentika. Tombeau d'un gouverneur de l'Oasis à la fin de l'Ancien Empire. *Balat V. Fouilles de l'Institut français d'archéologie orientale* 40 (Le Caire: Institut français d'archéologie orientale).
- Caton-Thompson, G. (1931) Royal Anthropological Institute's Prehistoric Research Expedition to Kharga Oasis, Egypt. Preliminary Outline of the Season's Work. *Man* 31: 77–84.
- (1952) *Kharga Oasis in Prehistory. With a Physiographic Introduction by E.W. Gardner* (London: Athlone Press).
- Caton-Thompson, G. & E.W. Gardner (1934) *The Desert Fayum* [2 vols.: text and plates] (London: The Royal Anthropological Institute).
- Clayton, J., A. De Trafford & M. Borda (2008) A Hieroglyphic Inscription found at Jebel Uweinat mentioning Yam and Tekhebet. *Sahara* 19: 129–134.
- Couyat, J. & P. Montet (1912) Les inscriptions hiéroglyphiques et hiératiques du Ouâdi Hammâmât. *Mémoires publiés par les membres de l'Institut français d'archéologie orientale du Caire* 34 (Le Caire: Institut français d'archéologie orientale du Caire).
- Darnell, J.C. (1986) Irem and the Ghost of Kerma. *Göttinger Miszellen* 94: 17–23.
- (2003) A Stela of the Reign of Tutankhamun from the Region of Kurkur Oasis. *Studien zur Altägyptischen Kultur* 31: 73–91.
- Davies, N. de Garis (1906) The rock tombs of El Amarna. Part IV: The tombs of Penthu, Mahu, and others. *Archaeological Survey of Egypt, Memoir* 16 (London: Egypt Exploration Fund).
- (1963) Scenes from some Theban tombs (nos. 38, 66, 162, with excerpts from 81). *Private Tombs at Thebes* 4 (Oxford: Oxford University Press).
- Dercksen, J.G. (2004) *Old Assyrian Institutions. MOS Studies 4 / Uitgaven van het Nederlands Instituut voor het Nabije Oosten te Leiden* 98 (Leiden: Nederlands Instituut voor het Nabije Oosten).
- Dill, D.B. (1938) *Life, Heat, and Altitude. Physiological Effects of Hot Climates and Great Heights* (Cambridge: Harvard University Press).
- Ecclestone, M.J. (2002) Macroscopic and Microscopic Analysis of New Kingdom Dakhleh Oasis Amphorae Fabrics. In: R.F. Friedman (ed.), *Egypt and Nubia: Gifts of the Desert* (London: British Museum Press) 106–109.
- Engelbach, R. (1933) The Quarries of the Western Nubian Desert. *Annales du Service des Antiquités de l'Égypte* 33: 65–74.
- (1938) The Quarries of the Western Nubian Desert and the Ancient Road to Tushka. *Annales du Service des Antiquités de l'Égypte* 38: 369–390.
- Engels, L., L. Bavay & A. Tsingarida (2009) Calculating vessel capacities: A new web-based solution. In: A. Tsingarida (ed.), *Shapes and Uses of Greek Vases (7th – 4th centuries B.C.). Études d'archéologie 3* (Bruxelles: Centre de Recherches en Archéologie et Patrimoine, Université libre de Bruxelles) 129–133.
- Erman, A. & H. Grapow (1926–1931) *Wörterbuch der ägyptischen Sprache*, vol. 1–5 (Leipzig: Hinrichs'sche Buchhandlung).
- Faltings, D. (1998) Die Keramik der Lebensmittelproduktion im Alten Reich. Ikonographie und Archäologie eines Gebrauchsartikels. *Studien zur Archäologie und Geschichte Altägyptens* 14 (Heidelberg: Heidelberg Orientverlag).
- Faulkner, R.O. (1942) The Battle of Meggido. *Journal of Egyptian Archaeology* 28: 2–15.
- Förster, F. (2007a) With donkeys, jars and water bags into the Libyan Desert: the Abu Ballas Trail in the late Old Kingdom/First Intermediate Period. *British Museum Studies in Ancient Egypt and Sudan* 7: 1–36.
- (2007b) The Abu Ballas Trail: a Pharaonic donkey-caravan route in the Libyan Desert (SW-Egypt). In: O. Bubenz, A. Bolten & F. Darius (eds.), *Atlas of Cultural and Environmental Change in Arid Africa. Africa Praehistorica* 21 (Köln: Heinrich-Barth-Institut) 130–133.
- (2010) Gottes Ohr in der Wüste. Ein demotisch und hieroglyphisch beschrifteter Steinblock von einem sogenannten *hilltop site* südlich der Oase Dachla. In: H. Knuf, C. Leitz & D. von Recklinghausen (eds.), *Honi soit qui mal y pense. Studien zum pharaonischen, griechisch-römischen und spätantiken Ägypten zu Ehren von Heinz-Josef Thissen. Orientalia Lovaniensia Analecta* 194 (Leuven et al.: Peeters Publishers) 69–78.
- (2011) *Der Abu Ballas-Weg. Eine pharaonische Karawanenroute durch die Libysche Wüste*. Unpublished Ph.D. thesis, University of Cologne.

- Förster, F., H. Riemer, A. Bolten, O. Bubenzer, S. Hendrickx & F. Darius (2010) Tracing Linear Structures: Remote Sensing, Landscape Classification and the Archaeology of Desert Roads in the Eastern Sahara. In: W.J.G. Möhlig, O. Bubenzer & G. Menz (eds.), *Towards Interdisciplinarity. Experiences of the Long-term ACACIA Project. Topics in Interdisciplinary African Studies* 15 (Köln: Rüdiger Köppe) 49–75.
- Frankfort, H. & J.D.S. Pendlebury (1933) *The City of Akhenaten, Part II. The North Suburb and the Desert Altars. Excavation Memoirs* 40 (London: Egypt Exploration Society).
- Franzmeier, H. (2008) Wells and Cisterns in Pharaonic Egypt: The Development of a Technology as a Progress of Adaptation to Environmental Situations and Consumers' Demands. In: K. Griffin (ed.), *Current Research in Egyptology 2007. Proceedings of the Eighth Annual Symposium which Took Place at Swansea University, April 2007* (Oxford: Oxbow) 37–51.
- Gabriel, B. (1986) *Die östliche Libysche Wüste im Jungquartär. Berliner geographische Studien* 19 (Berlin: Institut für Geographie der Technischen Universität Berlin).
- Gasse, A. (1994) L'approvisionnement en eau dans les mines et carrières. In: B. Menu (ed.), *Les problèmes institutionnels de l'eau en Égypte ancienne et dans l'Antiquité méditerranéenne. Colloque AIDEA Vogüé 1992. Bibliothèque d'Étude* 110 (Le Caire: Institut français d'archéologie orientale du Caire) 169–176.
- Graeff, J.-P. (2005) *Die Straßen Ägyptens* (Berlin: dissertationen.de).
- Groves, C.P. (1974) *Horses, Asses and Zebras in the Wild* (Newton Abbot: David & Charles).
- Hamilton-Dyer, S. (1998) Roman Egypt – Provisioning the Settlements of the Eastern Desert, with Particular Reference to the Quarry Settlement of Mons Claudianus. In: C.M. Mills & G. Coles (eds.), *Life on the Edge: Human Settlement and Marginality. Symposia of the Association for Environmental Archaeology* No. 13. *Oxbow Monograph* 100 (Oxford: Oxbow) 121–126.
- Hannig, R. (2003) *Ägyptisches Wörterbuch I: Altes Reich und Erste Zwischenzeit* (Hannig-Lexica 4). *Kulturgeschichte der antiken Welt* 98 (Mainz: Philipp von Zabern).
- Hayes, W.C. (1953) *The Scepter of Egypt. A Background for the Study of the Egyptian Antiquities in The Metropolitan Museum of Art. Part I: From the Earliest Times to the End of the Middle Kingdom* (New York: Harper).
- Henein, N.H. (1997) *Poterie et potiers d'al-Qasr, Oasis de Dakhla. Bibliothèque d'Étude* 116 (Le Caire: Institut français d'archéologie orientale).
- Hoellriegel, A. [alias R.A. Bermann] (1938) *Zarzura, die Oase der kleinen Vögel. Die Geschichte einer Expedition in die Libysche Wüste* (Zürich: Füssli).
- Holthoer, R. (1977) *New Kingdom Pharaonic Sites. The Pottery. Scandinavian Joint Expedition to Sudanese Nubia* 5:1 (Copenhagen: Munksgaard).
- (1993) *The Pottery*. In: J. Baines (ed.), *Stone Vessels, Pottery and Sealings from the Tomb of Tut'ankhamun* (Oxford: Griffith Institute & Ashmolean Museum) 37–85.
- Hope, C.A. (1979) *Dakhleh Oasis Project. Report on the Study of the Pottery and Kilns. Journal of the Society for the Study of Egyptian Antiquities* 9: 187–201.
- (1980) *Dakhleh Oasis Project. Report on the Study of the Pottery and Kilns. Journal of the Society for the Study of Egyptian Antiquities* 10: 283–313.
- (1983) *Dakhleh Oasis Project. Preliminary Report on the Study of the Pottery. Fifth Season, 1982. Journal of the Society for the Study of Egyptian Antiquities* 13: 142–153.
- (1989) *Amphorae of the New Kingdom. In: C.A. Hope, Pottery of the Egyptian New Kingdom: Three Studies. Occasional Paper* 2 (Burwood: Victoria College, Archaeology Research Unit) 85–110.
- (1999) *Pottery Manufacture in the Dakhleh Oasis. In: C.S. Churcher & A.J. Mills (eds.), Reports from the Survey of the Dakhleh Oasis, Western Desert of Egypt, 1977–1987. Oxbow Monograph* 99 / *Dakhleh Oasis Project Monograph* 2 (Oxford: Oxbow) 215–250.
- (2000) *Kegs and Flasks from the Dakhleh Oasis. Cahiers de la céramique égyptienne* 6: 189–210.
- (2002) *Early and Mid-Holocene Ceramics from the Dakhleh Oasis: Traditions and Influences. In: R. Friedman (ed.), Egypt and Nubia: Gifts of the Desert* (London: British Museum Press) 39–61.
- (2005) *Mut el-Kharab: Seth's City in Dakhleh Oasis. Egyptian Archaeology* 27: 3–6.
- (2007) *Egypt and 'Libya' to the End of the Old Kingdom: A View from Dakhleh Oasis. In: Z.A. Hawass & J. Richards (eds.), The Archaeology and Art of Ancient Egypt. Essays in Honor of David B. O'Connor. Annales du Service des Antiquités de l'Égypte, Cahiers* 36/2 (Le Caire: Service des Antiquités de l'Égypte) 399–415.
- Hope, C.A., M. Eccleston, P. Rose & J. Bourriau (2002) *Oases Amphorae of the New Kingdom. In: R.F. Friedman (ed.), Egypt and Nubia: Gifts of the Desert* (London: British Museum Press) 95–131.
- Hope, C.A., G.E. Bowen, W. Dolling, E. Healey, J. Milner & O.E. Kaper (2008) *The Excavations at Mut el-Kharab, Dakhleh Oasis in 2008. Bulletin of the Australian Centre for Egyptology* 19: 49–71.
- Jarvis, C.S. (1936) *Three Deserts* (London: John Murray).
- Jeuthe, C. (2012) *Ein Werkstattkomplex im Palast der 1. Zwischenzeit in Ayn Asil. Balat X. Fouilles de l'Institut français d'archéologie orientale* 71 (Le Caire: Institut français d'archéologie orientale).
- Jones, N.L., K.A. Houpt & T.R. Houpt (1989) *Stimuli of Thirst in Donkeys (Equus asinus). Physiology & Behavior* 46: 661–665.
- Kaper, O.E. & H. Willems (2002) *Policing the Desert: Old Kingdom Activity around the Dakhleh Oasis. In: R.F. Friedman (ed.), Egypt and Nubia: Gifts of the Desert* (London: British Museum Press) 79–94.
- Keimer, L. (1952–1953) *Notes prises chez les Bišarīn et les Nubiens d'Assouan (cinquième partie, suite). Bulletin de l'Institut d'Égypte* 35: 447–533.

- Kemal el Dine, H. & L. Franchet (1927) Les dépôts de jarres du désert de Lybie [*sic*]. *Revue scientifique* 65: 596–600.
- Kuhlmann, K.P. (1988) Das Ammoneion: Archäologie, Geschichte und Kultpraxis des Orakels von Siwa. *Archäologische Veröffentlichungen des Deutschen Archäologischen Instituts, Abteilung Kairo* 75 (Mainz: Philipp von Zabern).
- (2002) The “Oasis Bypath” or The Issue of Desert Trade in Pharaonic Times. In: “Jennerstrasse 8” (ed.), *Tides of the Desert – Gezeiten der Wüste. Contributions to the Archaeology and Environmental History of Africa in Honour of Rudolph Kuper. Africa Praehistorica* 14 (Köln: Heinrich-Barth-Institut) 125–170.
- Kuper, R. (2001) By Donkey Train to Kufra? – How Mr Meri Went West. *Antiquity* 75: 801–802.
- (2002) Routes and Roots in Egypt’s Western Desert. The Early Holocene Resettlement of the Eastern Sahara. In: R.F. Friedman (ed.), *Egypt and Nubia: Gifts of the Desert* (London: British Museum Press) 1–12.
- (2003a) The Abu Ballas Trail: Pharaonic Advances into the Libyan Desert. In: Z. Hawass & L. Pinch Brock (eds.), *Egyptology at the Dawn of the Twenty-First Century. Proceedings of the Eighth International Congress of Egyptologists, Cairo 2000, Vol. 2: History, Religion* (Cairo/New York: American University in Cairo Press) 372–376.
- (2003b) Les marches occidentales de l’Égypte: dernières nouvelles. *Bulletin de la Société française d’Égyptologie* 158: 12–34.
- Kuper, R. & S. Kröpelin (2006) Climate-Controlled Holocene Occupation in the Sahara: Motor of Africa’s Evolution. *Science* 313: 803–807.
- Lichtheim, M. (1988) *Ancient Egyptian Autobiographies Chiefly of the Middle Kingdom. A Study and an Anthology. Orbis biblicus et orientalis* 84 (Freiburg, Schweiz/Göttingen: Universitäts-Verlag).
- Maloiy, G.M.O. (1970) Water Economy of the Somali Donkey. *American Journal of Physiology* 219: 1522–1527.
- Maloiy, G.M.O. & C.D.H. Boarer (1971) Response of the Somali donkey to dehydration: hematological changes. *American Journal of Physiology* 221 (1): 37–41.
- Marchand, S. (2000) Les siges des Oasis datées de la XXVIIe–XXIXe dynastie et de l’époque ptolémaïque ancienne trouvées à Ayn Manâwîr (Oasis de Kharga) et à Tebtynis (Fayoum). *Cahiers de la céramique égyptienne* 6: 221–225.
- (2004) Fouilles récentes dans la zone urbaine de Dendara: La céramique de la fin de l’Ancien Empire au début de la XIIe dynastie. *Cahiers de la céramique égyptienne* 7: 211–238.
- Marchand, S. & G. Soukiasian (2010) Un habitat de la XIIIe dynastie – 2e Période Intermédiaire à Ayn Asil. *Fouilles de l’Institut français d’archéologie orientale* 59 (Le Caire: Institut français d’archéologie orientale).
- Marchand, S. & P. Tallet (1999) Ayn Asil et l’oasis de Dakhla au Nouvel Empire. *Bulletin de l’Institut français d’archéologie orientale* 99: 307–352.
- McDonald, M.M.A. (1999) Neolithic Cultural Units and Adaptations in the Dakhleh Oasis. In: C.S. Churcher & A.J. Mills (eds.), *Reports from the Survey of the Dakhleh Oasis, Western Desert of Egypt, 1977–1987. Oxbow Monograph* 99 / *Dakhleh Oasis Project Monograph* 2 (Oxford: Oxbow) 117–132.
- (2002) Dakhleh Oasis in Predynastic and Early Dynastic times: Bashendi B and the Sheikh Muftah Cultural Units. *Archéo-Nil* 12: 109–120.
- Meerpohl, M. (2009) Kamele und Zucker. *Transsahara-Handel zwischen Tschad und Libyen. Ph.D. dissertation, University of Cologne.* <<http://kups.ub.uni-koeln.de/3263/>> (April 2011)
- Mills, A.J. (1999) Pharaonic Egyptians in the Dakhleh Oasis. In: C.S. Churcher & A.J. Mills (eds.), *Reports from the Survey of the Dakhleh Oasis, Western Desert of Egypt, 1977–1987. Oxbow Monograph* 99 / *Dakhleh Oasis Project Monograph* 2 (Oxford: Oxbow) 171–178.
- Minault-Gout, A. (1992) Le mastaba d’Ima-Pepi (Mastaba II), fin de l’Ancien Empire. *Balat II. Fouilles de l’Institut français d’archéologie orientale* 33 (Le Caire: Institut français d’archéologie orientale).
- Müller, V. (2008) Opferdeponierungen in der Hyksoshauptstadt Auaris (Tell el-Dab’a) vom späten Mittleren Reich bis zum frühen Neuen Reich. *Tell el-Dab’a XVII. Österreichische Akademie der Wissenschaften, Denkschriften der Gesamtakademie* 45 / *Untersuchungen der Zweigstelle Kairo des Österreichischen Archäologischen Institutes* 29 (Wien: Verlag der Österreichischen Akademie der Wissenschaften).
- Murray, G.W. (1935) *Sons of Ishmael. A Study of the Egyptian Bedouin* (London: Routledge & Sons).
- (1939) The Road to Chephren’s Quarries. *Geographical Journal* 94: 97–114.
- Nagel, G. (1938) La céramique du Nouvel Empire à Deir el Médineh. *Documents de fouilles de l’Institut français d’archéologie orientale* 10 (Le Caire: Institut français d’archéologie orientale).
- Nashef, K. (1987) Rekonstruktion der Reiserouten zur Zeit der altassyrischen Handelsniederlassungen. *Tübinger Atlas des Vorderen Orients, Beihefte Reihe B, Nr. 83* (Wiesbaden: Harrassowitz).
- Nordström, H.-A. & J.D. Bourriau (1993) Ceramic Technology: Clays and Fabrics. In: D. Arnold & J.D. Bourriau (eds.), *An Introduction to Ancient Egyptian Pottery. Sonder-schriften des Deutschen Archäologischen Instituts, Abteilung Kairo* 17 (Mainz: Philipp von Zabern) 143–190.
- Osborn, D.J. & J. Osbornová (1998) *The Mammals of Ancient Egypt. The Natural History of Egypt* 4 (Warminster: Aris & Phillips).
- Pantalacci, L. (1998) La documentation épistolaire du palais des gouverneurs à Balat-Ayn Asil. *Bulletin de l’Institut français d’archéologie orientale* 98: 303–315.

- Peacock, D.P.S. (1997) Routes and Transportation. In: D.P.S. Peacock & V.A. Maxfield, Survey and Excavation. Mons Claudianus 1987–1993. Volume 1: Topography and Quarries. Fouilles de l'Institut français d'archéologie orientale 37 (Le Caire: Institut français d'archéologie orientale) 259–274.
- (2000) The Roman Period. In: I. Shaw (ed.), The Oxford History of Ancient Egypt (Oxford: Oxford University Press) 422–445.
- Redford, D.B. (2003) The Wars in Syria and Palestine of Thutmose III. Culture and History of the Ancient Near East 16 (Leiden/Boston: Brill).
- Rhotert, H. (1952) Libysche Felsbilder. Ergebnisse der XI. und XII. Deutschen Inner-Afrikanischen Forschungs-Expedition (DIAFE) 1933/1934/1935. Veröffentlichung des Frobenius-Instituts an der Johann Wolfgang Goethe-Universität, Frankfurt am Main (Darmstadt: L.C. Wittich).
- Rice, P.M. (1987) Pottery Analysis. A Sourcebook (Chicago: The University of Chicago Press).
- Riemer, H. (2002) Trouvailles prédynastiques et des premières dynasties du désert de l'Ouest et libyque. Résultats du projet ACACIA. Archéo-Nil 12: 95–100.
- (2004) News about the Clayton Rings: Long Distance Desert Travellers during Egypt's Predynastic. In: S. Hendrickx, R.F. Friedman, K.M. Ciałowicz & M. Chłodnicki (eds.), Egypt at its Origins. Studies in Memory of Barbara Adams. Proceedings of the International Conference "Origin of the State. Predynastic and Early Dynastic Egypt", Krakow, 28th August – 1st September 2002. Orientalia Lovaniensia Analecta 138 (Leuven et al.: Peeters Publishers) 971–989.
- (2009) A potsherd from northwest of Abu Minqar and the dispersal of Sheikh Muftah pottery in the Western Desert of Egypt. Sahara 20: 57–62.
- (2011) El Kharafish. The archaeology of Sheikh Muftah pastoral nomads in the desert around Dakhla Oasis (Egypt). Africa Praehistorica 25 (Köln: Heinrich-Barth-Institut).
- Riemer, H. & R. Kuper (2000) "Clayton rings": enigmatic ancient pottery in the Eastern Sahara. Sahara 12: 91–100.
- Riemer, H., F. Förster, S. Hendrickx, B. Eichhorn, S. Nußbaum, N. Pöllath, P. Schönfeld & G. Wagner (2005) Zwei pharaonische Wüstenstationen südwestlich von Dachla. Mitteilungen des Deutschen Archäologischen Instituts, Abteilung Kairo 61: 291–350.
- Roe, A. (2005–2006) The Old *Darb al Arbein* Caravan Route and Kharga Oasis in Antiquity. Journal of the American Research Center in Egypt 42: 119–129.
- Schmidt-Nielsen, K. (1965) Desert Animals. Physiological Problems of Heat and Water (Oxford: Clarendon Press).
- Schönfeld, P. (2004) Wegstationen auf dem Abu Ballas Trail. Dynastische Fundplätze aus der Western Desert Ägyptens. Unpublished MA thesis, Rheinische Friedrich-Wilhelms-Universität zu Bonn [summary in Archäologische Informationen 30/1, 2007: 133–140].
- Seidlmayer, S.J. (1990) Gräberfelder aus dem Übergang vom Alten zum Mittleren Reich. Studien zur Archäologie der Ersten Zwischenzeit. Studien zur Archäologie und Geschichte Altägyptens 1 (Heidelberg: Heidelberger Orientverlag).
- Seligman, C.G. (1934) Egypt and Negro Africa: A Study in Divine Kingship (London: Routledge & Sons).
- Sers, J.-F. (1994) Désert libyque (sous la direction de Théodore Monod) (Paris: Arthaud).
- Sethe, K. (1933) Urkunden des Alten Reichs I. Urkunden des ägyptischen Altertums, 1. Abt., Bd. I (Leipzig: J.C. Hinrichs).
- Shaw, B.D. (1979) The Camel in Roman North Africa and the Sahara: History, Biology, and Human Economy. Bulletin de l'Institut Fondamental d'Afrique noire (sér. B) 41: 663–721.
- Shaw, I. (2009) Non-textual marks and the twelfth Dynasty dynamics of centre and periphery: A case-study of potmarks at the Gebel el-Asr gneiss quarries. In: P. Andrassy, J. Budka & F. Kammerzell (eds.), Non-textual marking systems, writing and pseudo script from prehistory to modern times. Lingua Aegyptia, Studia monographica 8 (Göttingen: Seminar für Ägyptologie und Koptologie) 69–82.
- Shaw, I., E. Bloxam, T. Heldal & P. Storemyr (2010) Quarrying and landscape at Gebel el-Asr in the Old and Middle Kingdoms. In: F. Raffaele, M. Nuzzolo & I. Incordino (eds.), Recent Discoveries and Latest Researches in Egyptology. Proceedings of the First Neapolitan Congress of Egyptology, Naples, June 18th–20th 2008 (Wiesbaden: Harrassowitz) 293–312.
- Shaw, W.B.K. & D. Newbold (1928) Supplies, equipment, water, etc., for men and camels (Appendix VIII). Sudan Notes and Records 11: 171–181.
- Smith, D.G. & R.A. Pearson (2005) A Review of the Factors Affecting the Survival of Donkeys in Semi-arid Regions of Sub-Saharan Africa. Tropical Animal Health and Production 37, Suppl. 1: 1–19.
- Soukiassian, G., M. Wuttmann, L. Pantalacci, P. Ballet & M. Picon (1990) Les ateliers de potiers d'Ayn-Asil. Fin de l'Ancien Empire, Première Période intermédiaire. Balat III. Fouilles de l'Institut français d'archéologie orientale 34 (Le Caire: Institut français d'archéologie orientale).
- Soukiassian, G., M. Wuttmann & L. Pantalacci (2002) Le palais des gouverneurs de l'époque de Pépy II: Les sanctuaires de ka et leurs dépendances. Balat VI. Fouilles de l'Institut français d'archéologie orientale 46 (Le Caire: Institut français d'archéologie orientale).
- Spalinger, A.J. (2005) War in Ancient Egypt: the New Kingdom (Malden, Mass.: Blackwell).
- Thalmann, J.-P. (2007) A Seldom Used Parameter in Pottery Studies: The Capacity of Pottery Vessels. In: M. Bietak & E. Czerny (eds.), The Synchronisation of Civilisations in the Eastern Mediterranean in the Second Millennium B.C. III. Proceedings of the SCIEM 2000 – 2nd EuroConference, Vienna, 28th of May – 1st of June 2003. Österreichische Akademie der Wissenschaften, Denkschriften der Gesamtkademie 37 (Wien: Österreichische Akademie der Wissenschaften) 431–438.

- Thomas, A.P. (1981) Gurob. A New Kingdom Town. *Egyptology Today* 5 (Warminster: Aris & Phillips).
- Valloggia, M. (1986) Le mastaba de Medou-Nefer. Balat I. Fouilles de l'Institut français d'archéologie orientale 31,1–2 (Le Caire: Institut français d'archéologie orientale).
- (1998) Le monument funéraire d'Ima-Pepy/Ima-Meryrê. Balat IV. Fouilles de l'Institut français d'archéologie orientale 38,1–2 (Le Caire: Institut français d'archéologie orientale).
- van der Stappen, X. (2007) Le dromadaire. In: M.-C. Bruwier (ed.), *Pharaons noirs. Sur la Piste des Quarante Jours. Catalogue de l'exposition du 9 mars au 2 septembre 2007 par le Musée royal de Mariemont* (Mariemont: Musée royal de Mariemont) 327–330.
- von Beckerath, J. (1997) Chronologie des pharaonischen Ägypten. Die Zeitbestimmung der ägyptischen Geschichte von der Vorzeit bis 332 v. Chr. *Münchener Ägyptologische Studien* 46 (Mainz: Philipp von Zabern).
- Wainwright, G.A. (1935) [Review of:] C.G. Seligman, *Egypt and Negro Africa: A Study in Divine Kingship*. London 1934. *Journal of Egyptian Archaeology* 21: 259–261.
- Warfe, A.R. (2006) Reconsidering the argument for an early Holocene pottery tradition in Dakhleh Oasis, central Western Desert, Egypt. *Sahara* 17: 19–28.
- Winlock, H.E. (1936) Ed Dakhleh Oasis. *Journal of a Camel Trip Made in 1908*. With an Appendix by L. Bull. The Metropolitan Museum of Art, Department of Egyptian Art, vol. V (New York: Metropolitan Museum of Art).