

ORIGINAL ARTICLE



Innovative hybrid coupled wall systems to resist seismic action – HYCAD

Rajarshi Das¹ | Francesco Morelli² | Alessandro Zona³ | Benno Hoffmeister⁴ | Cristian Vulcu⁵
| Herve Degee⁶

Correspondence

Prof. Herve Degee
Hasselt University
Construction Engineering Research Group
Applicatiecentrum beton en bouw,
Wetenschapspark 34,
3590 Diepenbeek, Belgium
Email: herve.degee@uhasselt.be

^{1,6} Construction Engineering Research Group, Hasselt University, Diepenbeek, Belgium

² Department of Civil and Industrial Engineering, University of Pisa, Pisa, Italy

³ School of Architecture and Design, University of Camerino, Ascoli Piceno, Italy

^{4,5} Institute of Steel Construction, RWTH Aachen University, Germany

Abstract

This article summarizes the research carried out in the ongoing HYCAD project, which aims to improve the performances of a hybrid coupled wall (HCW) system for buildings in seismic areas, by further developing the HCW originally studied in the RFCS project INNO-HYCO. This HCW system consisted of a reinforced concrete (RC) wall coupled with two steel side-columns via steel coupling links. Encouraging outcomes were obtained such as: controlled post-elastic ductile behaviour under medium- and high-intensity earthquakes, suitable lateral stiffness, seismic energy dissipation concentrating in the easily-replaceable steel links and very limited damage in the RC wall. However, advanced studies were required to bring this system into practice, addressing issues and develop advancements in the analysis, design, and detailing. This article summarizes the primary steps taken towards that purpose. Five new components were chosen in order to improve the performance of the HCW system: (1) Link-to-wall connections using post-tensioned tendons; (2) Composite walls with encased steel profiles instead of a conventional RC wall; (3) Rocking coupled wall system; (4) Dissipating devices as links and (5) Precast double slab wall systems. Combining these components, four new HCW systems were developed, pre-designed and analysed through numerical and experimental studies. Advanced yet simple techniques were proposed for the numerical analyses while test specimens are used to characterize local and global behaviour.

Keywords

Steel-concrete hybrid coupled wall systems, Post-tensioned connections, Rocking base, Composite walls, Dissipative devices, Double slab walls, Prefabricated walls

1 Introduction

The EU-RFCS research project “HYCAD” [1] aims at contributing to the use of improved innovative hybrid coupled walls (HCW) for buildings in seismic areas, further developing the innovative HCWs proposed and analysed in the 2011-2013 RFCS research project Inno-Hyco [2]. The Inno-Hyco HCW system was made of a reinforced concrete (RC) wall coupled to two steel side columns via steel links, as shown in Fig. 1 (left). The RC wall carries almost all the horizontal shear force while the overturning moments are partially resisted by an axial tension-compression couple developed by the two steel columns rather than by the individual flexural action of the wall alone. The RC wall was designed to remain in the elastic field (or undergo limited damages only) while the steel links were designed as the only dissipative elements. The connections between the steel links (I-beams) and the steel side-columns were designed as a pinned connection which ensures the transmission of shear forces while the side-columns are subjected to compression/traction with reduced bending

moments. The primary focus of this HCW solution was that, the structure could be repaired easily as the damages were consciously targeted in the steel links. Furthermore, the Inno-Hyco outcomes showed that the proposed HCW system can achieve controlled post-elastic ductile behaviour under medium- and high-intensity earthquakes, lateral stiffness, ability to avoid non-structural damage for the more frequent low-intensity earthquakes, seismic energy dissipation effectively concentrated in steel dissipative components that can be easily replaced after seismic events, very limited damage in the RC wall etc. In addition, the proposed solutions were shown to be cost-effective with no particular problems in the construction process. Thus, the proposed HCW system was considered as an effective upgrade compared to the previous solutions with similar typologies [2]. However, more studies were deemed crucial in order to foster the application and diffusion of such an innovative structural system in the construction market. To that purpose, definite research advancements were proposed in the frame of the HYCAD EU-RFCS research project [1] – (1) Simpler yet accurate tools

to evaluate and assess different design options, comprising a deeper understanding of the dynamic behaviour of the HCW systems; (2) development of a simplified seismic design based on linear (static or dynamic) analysis and reduction factor as well as design recommendations – to fill the gap in the Eurocodes, where provisions for such structural systems in seismic areas are not adequate; (3) improvement, simplification and optimization of detailing in order to achieve a better structural behaviour of the HCWs under cyclic loads in conjunction with simpler design as well as easier and faster construction; (4) implementation of advanced hysteretic seismic devices, e.g. added damping and stiffness (ADAS) devices instead of the classical steel profiles; etc. Certain techniques were also identified to further analyse the structural behaviour of the HCW systems, such as a probabilistic approach (e.g. fragility curves) to obtain a highly reliable evaluation of different design strategies considering both the influence of the record-to-record variability and the uncertainties related to the component's capacity. Different components need to be considered in order to improve the overall performance of the innovative HCW system, such as:

- Improved link-to-wall connections
- Use of encased vertical steel profiles in the wall
- Dissipative devices in the links
- Global rocking of the wall
- Use of precast double slab walls

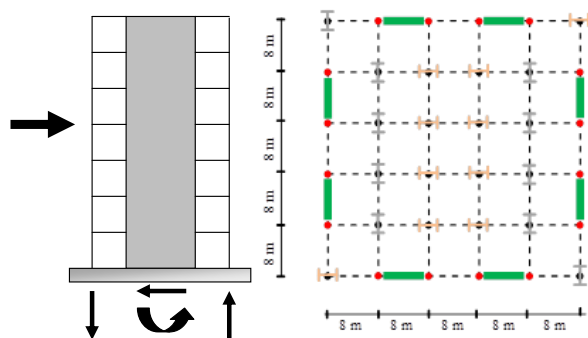

Figure 1 Inno-Hyco HCW system and the floor geometry with positions of the HCWs for the considered case studies [2].

Four different configurations have been developed for the HYCAD HCW systems, integrating the abovementioned components and are discussed in this article. Relevant tasks, numerical studies and pre-designs of experimental specimens are also summarized. Detailed information can be found in the midterm report of Project HYCAD [1] and other specific papers presented during Eurosteel 2023.

2 HYCAD HCW configurations

2.1 Types of Configurations

Although new components are integrated, the overall HCW design for the HYCAD configurations remains the same as the Inno-Hyco HCW systems.

2.1.1 Configuration 1

In coupled shear wall structures, the links are traditionally connected to the RC walls by embedded steel profiles. One practical issue concerning such a system has always con-

cerned the designers, namely the overcrowding of reinforcements in the RC wall's boundary zone, which makes it difficult to embed an additional steel profile into the RC wall. The first HYCAD configuration is chosen in order to minimize such a constructional issue. This configuration consists of a RC wall fixed at the base and coupled to two steel side columns via links, where the link-to-wall connection is realised with a steel plate connected to the RC wall face via post-tensioned tendons or rods and shear studs. As the ducts for the tendons or rods definitely takes lesser amount of space compared to a steel profile, they are able to overcome the issue of overcrowded boundary region of the wall. Furthermore, additional advantages have been beneficial to the design and construction, such as: (1) a straight-forward design for the tendons or bars; (2) easy addition of shear studs to provide the necessary shear strength to the connections; (3) a large restoring force to the wall piers provided by the unbonded post-tensioned beams compared to the embedded steel coupling beams, reducing the residual lateral displacements upon unloading from a nonlinear displacement and (4) a similar initial lateral stiffness alike a comparable system with embedded steel coupling beams. The RC wall is constructed as a precast double slab wall. Dissipative devices will be used instead of the conventional I or H-section links. A schematic diagram (Fig. 2) is shown below for further clarity. The moments and shear forces obtained from the Inno-Hyco systems – both global and local analysis, served as the preliminary basis for the pre-design.

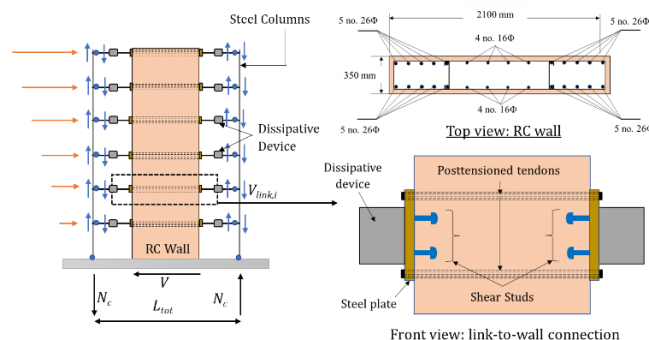

Figure 2 Schematic diagram of Configuration 1.

2.1.2 Configuration 2

Although overcrowding of steel elements becomes an issue for the embedded link-to-wall connections, it is not possible to compromise on longitudinal reinforcements as they provide the lateral strength to the RC walls – necessary to make the whole coupling system work. However, composite walls with multiple encased steel profiles serve as a promising alternative to avoid such an issue with certain advantages: (1) the required number of longitudinal reinforcements can be reduced as the encased steel sections directly contribute to the lateral strength of the wall; (2) the required number of horizontal reinforcements or stirrups can be significantly reduced as the encased steel profiles directly contribute to the shear strength of the wall; (3) a much higher strength and stiffness can be achieved by replacing the longitudinal rebars with small steel profiles; (4) encased steel sections at the boundaries improve the deformation capacity and energy dissipation capacity of the wall and (5) the links can be directly connected to the steel profiles encased in the composite wall.

The second configuration is developed foreseeing such advantages. The RC wall is replaced by a pre-cast double slab composite wall with vertical steel profiles (H- or U-section) encased or attached to its boundary zones fixed at the base and coupled to two steel side columns via conventional links (I- or H- profiles) as shown in Fig. 3. The links are connected to the web of the encased vertical steel sections using threaded rods, which are anchored at the center of the wall using a rectangular hollow section (RHS) box put in place during the prefabrication of the double-skin wall. Steel plates/shear studs are welded to the web of the encased vertical steel profiles as shear connectors to transmit the longitudinal shear from the steel profiles to the composite wall.

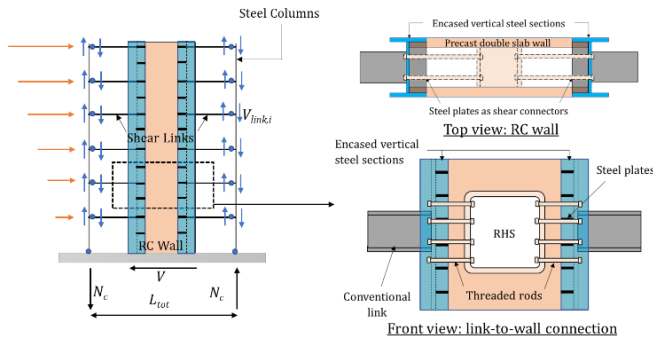

Figure 3 Schematic diagram of Configuration 2.

2.1.3 Configuration 3

Considering the modifications already made in Configuration 1 and Configuration 2, a third configuration is developed (Fig. 4). The wall is constructed as a cast-on-site composite wall section with vertical encased steel profiles with their web parallel to the longer wall face. The wall is coupled to two steel side columns via dissipative devices instead of conventional links or beam sections.

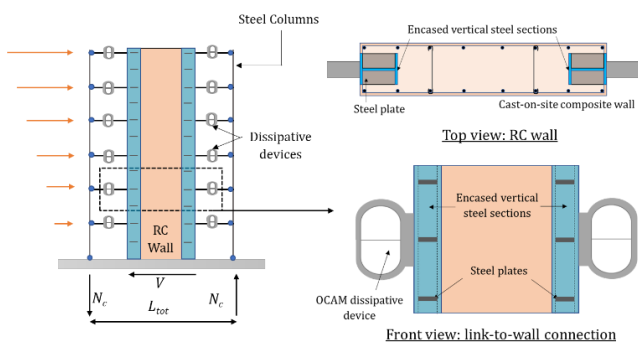

Figure 4 Schematic diagram of Configuration 3.

In this way, the structural performance of the composite wall HCW system can be compared with the conventional RC wall HCW system of Configuration 1 as well as the composite wall in Configuration 2 where the orientation of the encased steel profiles is different. The performance of the dissipative devices can also be compared with the conventional I- or H-links. Finally, the precast double slab composite wall system of Configuration 2 can be compared with the cast-on-site composite wall section of Configuration 3 to understand the economic and construction advantages and disadvantages

2.1.4 Configuration 4

The results achieved during the Inno-Hyco project highlighted the large quantity of steel reinforcements required in the RC wall to provide the design bending resistance needed to avoid damage at its base. Nevertheless, yielding of reinforcements and minor damages in the concrete might still occur if large design horizontal actions are experienced by the HCW system. Such condition could enforce complex and costly repairs at the base of the RC wall after major seismic events, reducing the resilience of the proposed solutions. Therefore, in order to reduce the possible damages in the RC wall and the subsequent repair interventions, a rocking solution is explored in Configuration 4 (Fig. 5), where the base of the RC wall is made of prefabricated casts separated from the foundation. The connection between the RC wall and the foundation is limited to two vertical steel elements that are designed to remain in the elastic range up to the required design bending strength of the wall while the horizontal shear is transferred from the RC wall to the foundation by a shear key designed to remain elastic, thus undamaged even after the vertical steel elements undergo yielding and possibly hardening. This solution will be constructed using prefabricated concrete elements connected to the foundation in the construction site. The connection between the RC wall and the vertical dissipative devices will be made through the use of steel plates to spread the concentrated axial forces, even if problems might arise when the traction is transmitted. Hence, an alternative solution is based on the adoption of steel profiles encased in the RC wall, leading to a simpler connection and a more effective transmission of tension forces. The main focus of this configuration is the design of the RC wall with rocking connections with or without encased steel profiles – based on ongoing research investigations. The design choices for the other elements will be derived from the outcomes of the analyses of the first three configurations.

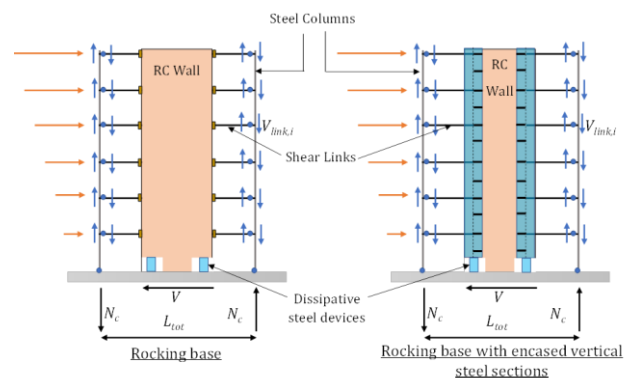

Figure 5 Schematic diagram of Configuration 4.

2.2 Analytical and experimental protocols

The newly proposed HCW systems were investigated based on the rules and regulations documented in the latest version of EN 1998-1-1 [3]. Both types of analyses – nonlinear static (pushover – section 6.5 of EN 1998-1-1) and dynamic (time history – section 6.6 of EN 1998-1-1) were conducted. The pushover analysis was conducted on an equivalent single-degree-of-freedom (SDOF) model, to verify the structural performance of the newly designed structures. Multi-mode pushover analyses with different

force distributions and multiple equivalent SDOF models were also conducted. A “modal” pattern of lateral forces was applied. The time-history analysis was conducted through direct numerical integration of its differential equations of motion, using the input motions selected in accordance with Clause 5.2.3.1 of EN 1998-1-1 [3]. The average peak response obtained from seven time-histories was considered to estimate the seismic action effects. The selection and scaling of the input motions were done according to Annex C of EN 1998-1-1. The relevant protocol for monotonic and cyclic tests on subsystems were selected based on the provisions of EN 15129 [4] and ECCS [5]. Important components were also finalized for experimental investigation through monotonic and cyclic tests: (1) Link-to-wall connection resorting to post-tensioned tendons or rods and shear studs; (2) Link-to-wall connection, for a composite wall with an attached side profile; (3) Cast-on-site composite wall and its connection with dissipative devices; (4) Rocking-base wall system.

2.3 Modelling technique for HYCAD HCWs

A frame finite-element (FE) approach was adopted to model the global systems for the chosen HYCAD HCW configurations in the open-source software OpenSees. Additionally, detailed 3D models were developed in the FE modeling software ABAQUS to investigate the different link-to-column and link-to-wall connection configurations.

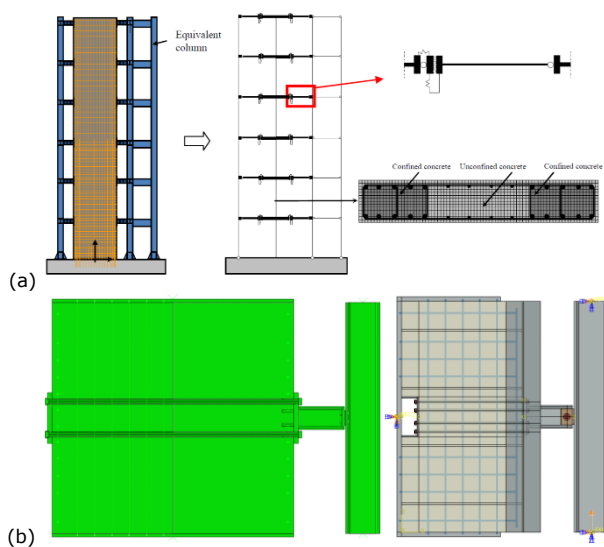

Figure 6 FE model of (a) the global HYCAD HCW system and (b) different link-to-wall and link-to-column connection configurations

- The steel links were modelled using the SteelBRB model implemented in OpenSees instead of linear elastic frame elements with lumped plasticity. This model considers the isotropic hardening explicitly and represents an improvement of the elastoplastic models with kinematic hardening (Fig. 6a – top right);
- A force-based distributed-plasticity fibre frame element was used to model the flexural behaviour of the RC wall and the shear behaviour was modelled as linear elastic w.r.t the flexural stiffness of the section. This model is a refined, rule-based, generalized, and non-dimensional constitutive model that allows calibration of the monotonic and hysteretic material modelling parameters, and can simulate the hysteretic behaviour of confined and unconfined, ordinary and

high-strength concrete, in both cyclic compression and tension (Fig. 6a – bottom right);

- The global HCW model was obtained by assembling the individual component models. Elements were placed in their actual positions and connected by means of rigid elements to describe the eccentricity of the connection systems (Fig. 6a – left);
- The link-to-column connections were modelled considering both partly fixed and pinned end-connections, to study their local behaviour as well as their influence on the global response of the HCW system (Fig. 6b).
- The link-to-wall connections were modelled separately resorting to solid elements for two types of configurations: (i) link-to-RC wall connection via post-tensioned tendons and (ii) conventional links connected to encased vertical members of a composite wall (Fig. 6b). The numerical models were primarily calibrated based on experimental and numerical studies available in the literature. More details can be found in [1].

3 Results and discussions

3.1 Global behaviour of the HCW

The global dynamic behaviour has been investigated for the two types of HCW systems:

1. *HYCAD fully fixed-based HCW system*, corresponding to Configuration 1, 2 and 3 of the proposed HCWs,
2. *HYCAD rocking-based HCW system*, corresponding to Configuration 4 of the proposed HCW systems.

A detailed parametric investigation was performed through 3 types of analyses: (i) Static nonlinear pushover analyses, (ii) Static cyclic nonlinear analyses, and (iii) Dynamic nonlinear time-history analysis. A 3-storey and a 6-storey building with coupling ratio $CR = 0.6$ (for both), were selected as case studies for both types of HCW systems and were investigated using 30 natural ground motion records – selected from the European Strong Motion Database and scaled to match (using REXEL), on average, the Eurocode 8 Type I soil category A pseudo-acceleration response spectrum, with $PGA = 0.20g$.

For *the HYCAD fixed base HCW systems*, a consistent delay was observed between the first and last link activation, allowing for a gradual transition from elastic to plastic response, ensuring a high level of controlled dissipation. As desired, the RC wall damage occurred after the yielding of all links. Despite the fact that the system is geometrically symmetrical, the RC wall introduced a source of asymmetry in the response due to the concrete cracks occurring in tension. The consideration of a realistic (asymmetrical) concrete constitutive law is essential to correctly catch the response of the building and the actual activation sequence of the links. A simplified modelling of the RC wall element with lumped plasticity (adopted in the Inno-Hyco studies) yields a conservative prediction of the performances. The maximum base shear reduces by more than 10% due to the II-order effects. From the dynamic analyses, it was seen that the maximum values regarding the top displacements range from 0.05 m to 0.16 m, with an average value of about 0.09 m and the maximum inter-storey drift (among floors – IDR) range from 0.4% to 1%, with an average value of about 0.5%.

The *HYCAD rocking base HCW systems* were investigated

with both, a “fixed” (Fig. 10c) and a “pinned” (Fig. 10d) connection at the base of the RC wall, in order to optimize the rocking behaviour of the wall. Several parameters were varied to study their influence on such HCW systems, such as: (i) vertical reinforcement ratios, (ii) length of the wall section, (iii) different loading scenarios, (iv) height of the vertical dissipative links, (v) different rebar arrangement in the cross section, (vi) difference in time placement of vertical links (before and after application of additional vertical loads), (vii) different vertical link profiles etc. Both systems were also compared between each other (Fig. 7) to note their advantages/disadvantages.

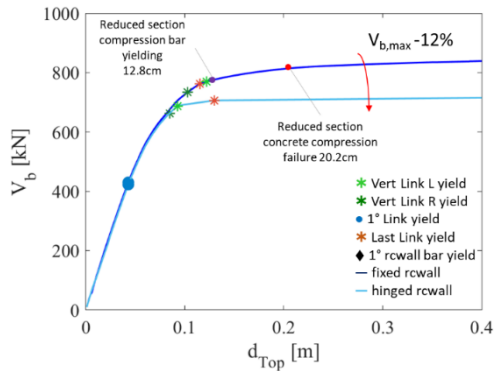

Figure 7 Comparison between capacity curves of equivalent fixed base and hinge base RC wall rocking HCW systems

3.2 Local behaviour of components/subsystems

Two individual components: (i) the RC wall, and (ii) the dissipative steel links, were investigated w.r.t experimental and numerical results available in the current literature to validate the modelling assumptions adopted in the global HCW systems. Encouraging results were obtained [1] as shown in Fig. 8.

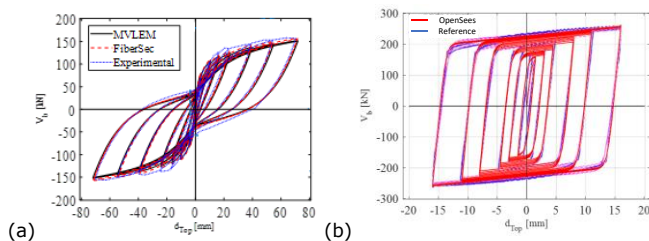

Figure 8 Comparison between numerical response and experimental results under cyclic test for (a) RC wall and (b) dissipative link models.

The link-to-column pinned and fixed connections were investigated as a separate task to understand either’s influence and suitability in the global performance of the HYCAD HCW systems. Based on the results, it could be concluded that the link-to-column fixed connections represent a very good solution that avoid, or at least minimize, the relative displacements between the link and the column and therefore maximizes the quantity of seismic energy dissipated. At the same time, such a solution is simple enough to be strongly competitive from an execution point of view. Two subsystems were further analysed and characterized based on detailed simulation results in order to identify the most suitable technical solution for the connection between the replaceable dissipative shear links, the wall and the side column:

1. RC wall with link-to-wall posttensioned connection

- and link-to-column quasi-pinned (end-plate with two bolt rows) connection as shown in Fig. 9a;
- Composite walls with steel links, threaded rods and link-to-column pinned (one web plate and one bolt) connection as shown in Fig. 9b.

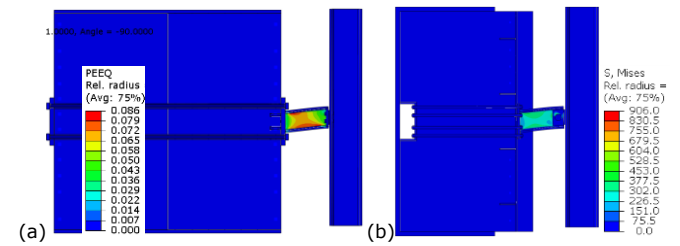

Figure 9 Plastic strain distribution in the whole model at failure for (a) link-to-RC wall posttensioned connection with tendons and (b) link-to-composite wall connection with threaded rods.

In particular, a direct load transfer mechanism was aimed, which would lead to an elastic response of the two connection zones and a yielding of the shear link only. Furthermore, the aim was also to develop a moment-resisting connection between the shear link and the wall and an optimum (simple/moment resisting) connection between the link and the external column. Based on the outcomes of the numerical investigations and the comparison between models, it could be concluded that:

- Overall the numerical models are characterized by similar global force–deformation curves justified by the main failure mechanism, i.e. yielding of the shear link, so having limited to no influence on the global behaviour;
- The best solution for the connection between the shear link and the external column consisted in an end-plate connection with two bolt rows; all other connection solutions evidenced local plastic deformations (i.e. yielding of plates and/or shear of the bolts);
- The shape of the encased steel profiles (HEA-360 or UPN-350) in the composite wall did not influence the load transfer mechanism;
- The shear connection between the encased steel profiles and the concrete was noted to be important, as the shear force from the link needs to be transferred to the concrete but not through the threaded rods or through post tensioned tendons;
- The number of shear connectors, as well as their material and shape, can improve the load transfer mechanism and reduce the local plastic deformations within the composite wall;
- It is necessary to adopt a post tensioning of the threaded rods and the tendons (which can have lengths in the range of 1.0 m or higher for threaded rods, respectively 2.0 m for tendons) as it was observed that, in this way, the initial stiffness increases.
- The shear studs need to be modelled not as embedded but using contact interaction, as it was observed to offer a more realistic response.

3.3 Experimental investigations

This section summarizes the preparation stages of the experimental tests on subsystems relevant to the proposed HYCAD HCW configurations. Four subsystems were developed and pre-designed:

a) *Subsystem 1*: HCW system with post-tensioned link-

- to-wall connection via tendons (Fig. 10a);
- b) *Subsystem 2*: HCW system with composite walls and link-to-wall connection via threaded rods (Fig. 10b);
- c) *Subsystem 3*: HCW system with a fixed rocking-base RC wall (Fig. 10c);
- d) *Subsystem 4*: HCW system with a pinned rocking-base RC wall (Fig. 10d).

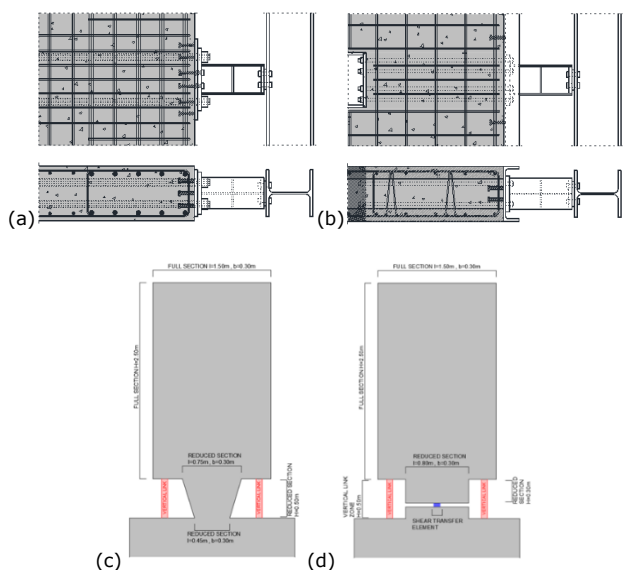

Figure 10 (a) Subsystem 1, (b) Subsystem 2, (c) Subsystem 3, (d) Subsystem 4

The primary aim of the full-scale tests on HCW subsystems is to validate the HYCAD solutions both from an execution and a mechanical point of view, and also to further calibrate the numerical models. An overall description on the constituting elements, dimensions of the test specimens, test-set-ups and additional relevant plans for the experimental campaign can be found in the midterm report of HYCAD [1]. The tests will be performed under both monotonic and cyclic loading. Coupon tests will be conducted for material samples (concrete and main steel parts).

4 A simplified analysis procedure

A simplified analysis procedure was further developed to analyse the innovative HYCAD HCW systems. 6-storey and 12-storey HCW systems were adopted as case studies in order to validate the simplified method. The nonlinear dynamic analyses were used as a reference to calibrate the simplified nonlinear static analysis. The results of the dynamic analyses carried out on the 6-storey and 12-storey HCW system showcased a strong dependence of the structural behavior on the higher vibration modes. Consequently, it was noted that the classical pushover analysis (i.e. according to the fundamental mode only) cannot correctly represent the behavior of the HCW system and that, it is necessary to adopt multimodal pushover analysis methods. The pushover curves obtained combining the contribution of the first three vibration modes led to a very good agreement between the IDA (combining the maximum base shear and the maximum displacement at the top of the structure) and pushover curves obtained with the OPENSEES model (see Fig. 11).

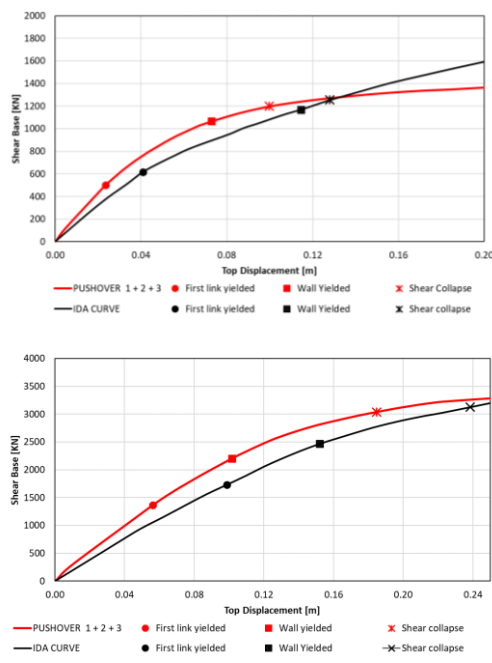

Figure 11 IDA vs Pushover curve for 6-storey (left) and for 12-storey (right) case studies

5 Conclusions

This article presents all the research investigations done till date in the frame of project HYCAD through relevant references, analytical calculations, numerical simulations as well as pre-design of test specimens and preparation for the upcoming experimental campaign. Different innovative types of HCW configurations have been suggested to overcome the drawbacks identified within the initial Inno-Hyco system and discussed along with highlighting the crucial structural components influencing their behaviour. Major findings/conclusions obtained from the research study are discussed in the article highlighting their impact and added value.

References

- [1] Degee H., et al. (2021) *HYCAD: Innovative steel-concrete hybrid coupled walls for buildings in seismic areas: advancements and design guidelines*. Midterm Report. 899381.
- [2] Dall'Asta A., et al. (2015) *INNOHYCO: Innovative hybrid and composite steel-concrete structural solutions for building in seismic area*. Final Report, EUR 26932 EN. Brussels, Belgium: European Commission.
- [3] Eurocode 8: Design of structures for earthquake resistance- Part 1-1: General rules and seismic action (EN 1998-1-1:2020, draft), Brussels, Belgium, CEN European Committee for Standardization.
- [4] CEN European Committee for Standardization: EN 15129, Anti-seismic devices, Brussels, Belgium, June 2010.
- [5] ECCS - European Convention for Constructional Steelwork, TC 1, TWG 1.3. "Recommended Testing Procedure for assessing the Behaviour of Structural Steel Elements under Cyclic Load", First Edition, 1986.